

FOREWORD

Thank you for selecting the Futaba ATTACK-II.

The ATTACK-II is a 2-channel digital proportional R/C set for R/C cars, boats (yachts), and other models. To enjoy its functions to the fullest and to ensure safe operation, please read this manual carefully before using your set. After reading this manual, store it in a safe place. If you encounter any difficulties while using your set, please refer to the appropriate sections in this manual. In addition to this manual, please read all of the manuals included with your car, engine and other related equipment you may use.

This manual covers "SET CONTENTS", "PREPARATIONS" before installation of the R/C set in the model, R/C set "ADJUSTMENTS", "PRECAUTIONS WHEN INSTALLING" the R/C set in the model, "OPERATIONS" of the R/C set, "OPERATING PRECAUTIONS", "USING OPTION PARTS", and "RATINGS" of the R/C set. If your R/C set appears to be faulty, check the "WHEN YOU THINK THE SET IS FAULTY" section. If the set is faulty, send it to be serviced in accordance with "REPAIR SERVICE".

(IMPORTANT) To help ensure safe use, pay particular attention to the precautions printed throughout this manual and indicated by an exclamation mark .

(ATTENTION)

1. Application of Product

This product is not intended for use in any application other than for the control of models for hobby and recreational purposes. This product is subject to regulations of the Ministry of Radio/Telecommunications and is restricted under Japanese law to such purposes. The laws of other countries may similarly restrict the use of this product. Futaba is not responsible for any use that is not in compliance with applicable law.

2. Exportation of Product

If the product is exported from Japan, the prior approval of the Ministry of Radio/Telecommunications is required regarding the country of destination. If this product is reexported from other countries, it may be subject to restrictions on such reexport and prior approval of government authorities may be required.

3. Modification, Adjustment & Replacement of Parts

Futaba is not responsible for any use of this product that is not in compliance with applicable law and disclaims all responsibility for any modification or alteration of the product, including the incorporation of the product into other products by third parties, that is not in compliance with applicable law.

The following statement applies to only Ni-Cd battery system:

The product that you have purchased contains a rechargeable battery. The battery is recyclable. At the end of its useful life, under various state and local laws, it may be illegal to dispose of this battery into the municipal waste stream. Check with your local solid waste officials for details in your area for recycling options or proper disposal. (for U.S.A.)

The following statement applies to the receiver:

THIS DEVICE COMPLIES WITH PART 15 OF THE FCC RULES. OPERATION IS SUBJECT TO THE FOLLOWING TWO CONDITIONS:
(1) THIS DEVICE MAY NOT CAUSE HARMFUL INTERFERENCE, AND
(2) THIS DEVICE MUST ACCEPT ANY INTERFERENCE RECEIVED, INCLUDING INTERFERENCE THAT MAY CAUSE UNDESIRE OPERATION.
(for U.S.A.)

* No part of this manual may be reproduced in any form without prior written permission.

* The contents of this manual are subject to change without prior notice.

* This manual has been carefully written, but please feel free to write to Futaba if you find that any corrections or clarification's that should be made.

* Futaba is not responsible for the results of the use of this product by the customer.

* Futaba and ATTACK are a registered trademark.

SET CONTENTS

TRANSMITTER FP-T2CR

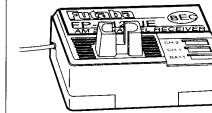
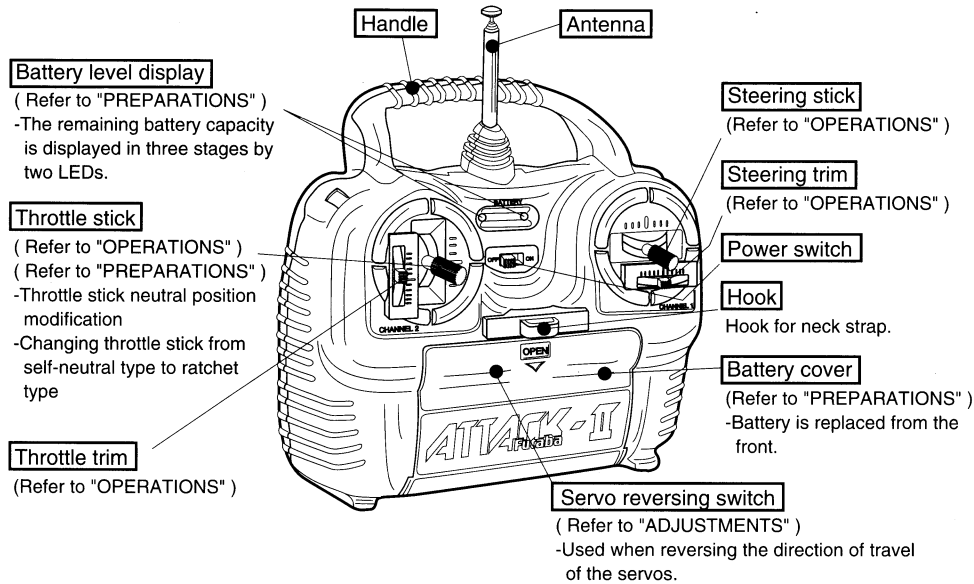

RECEIVER FP-R122JE / R112JE

- Thin and light weight.
- Built-in BEC (power supply up to 8.4V)
- Replaceable crystal.

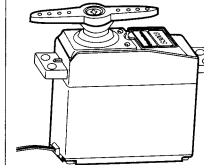

SERVO FP-S3003

- Light weight.
- Torque: 3.2kg-cm (44.4oz-in)
- Speed: 0.23sec/60degree

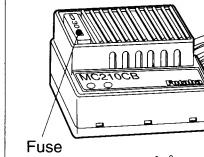

MOS FET ELECTRONIC SPEED CONTROL FP-MC210CB / FP-MC310CB

- With reverse and brake.
- Special heat sink provided as standard.
- Built-in neutral and HI point trimmers.
- Built-in heat protector and fuse.

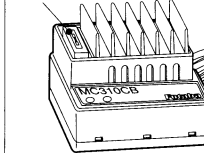

ATTACK-II SET CONTENTS

	Transmitter	Receiver	Servo	FET E.S.C.	Accessories
2-SERVO SET	FP-T2CR(x1)	FP-R122JE(x1) or FP-R112JE(x1)	FP-S3003(x2)		Switch CSW-BN(x1) and others
SET w/MC210CB			FP-S3003(x1)	MC210CB(x1)	Miniature screwdriver (x1) and others
SET w/MC310CB				MC310CB(x1)	

* A frequency board or flag is also supplied with each set.

OPERATING PRECAUTIONS

(IMPORTANT)

To use your R/C set safely, please observe the following precautions:

- ! When turning on the power, first turn on the transmitter power, then turn on the receiver power. When turning off the power, first turn off the receiver power, then turn off the transmitter power. (For engine models, stop the engine before turning off the receiver power.)
If the power is turned on or off in the reverse order, the receiver power will remain on and interference is possible.
- ! Extend the transmitter antenna to its full length. If the antenna is short, the transmitting output power will be less and the range will be less.
- ! Operating two radios on the same frequency is extremely dangerous because it will cause loss of control. Before turning your system on, check that the frequency is not in use. Just because the modulation method or signal format (AM, FM, PCM, etc.) is different does not mean that operating on the same frequency is possible.
- ! When the vehicle, boat (yacht) is not in use, always disconnect the running Ni-cd battery connector. Otherwise the motor may start unexpectedly and is dangerous.
- ! Do not run the vehicle on rainy days and through puddles. Since the transmitter, receiver, servo, FET E.S.C., and other parts do not have a waterproof construction, water may enter them and cause erroneous operation.
- ! When placing the transmitter on the ground during running (cruising) preparations, be sure that the wind cannot knock it over. IF it is knocked over, the throttle stick may be pushed to the full speed position.

! Always test your digital proportional R/C set before running (cruising). Have an assistant hold the model or place the model on a stand so that it cannot take off, then check if the servos and FET E.S.C. follow the movement of their control sticks.

! **Course**
Since the model runs at high speed, collisions are destructive and careful attention must be given to the presence of spectators, etc. Do not operate an R/C boat where there are row-boats. It is very dangerous because of collisions. In areas near high tension lines and communication facilities, consideration must be given to loss of control by radiowave interference.

Because R/C radiowaves have a fairly long range, a place at least 3km from other R/C activities is necessary.

PREPARATIONS

LOADING THE TRANSMITTER BATTERY

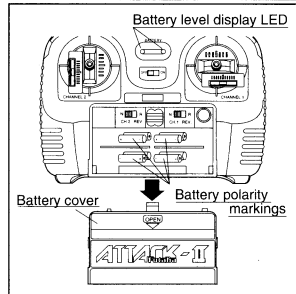

1. Remove the battery cover by sliding it in the arrow direction while pressing the part marked "OPEN".
2. Load the eight batteries in accordance with the polarity markings on the battery holder.
3. Slide the battery cover back onto the transmitter.

CHARGING THE NI-CD BATTERY

! Never try to charge a dry cell battery. Charging a dry cell battery will cause abnormal heating, etc. and is dangerous.

! Observe the charging current and charging time given on the Ni-cd battery used. A charging current or charging time exceeding the specified value will cause abnormal heating, etc. and is very dangerous.

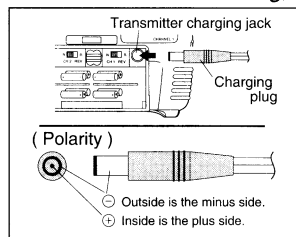

Transmitter with charging jack

Charge the battery by connecting a charging plug of an Futaba charger (sold separately) to the charging jack shown in the figure.

Transmitter without charging jack

Remove the Ni-cd battery from the transmitter and charge it.

* When you have not used your R/C set for sometime, repeatedly charge and discharge the batteries two or three times before use.

BATTERY LEVEL DISPLAY

1. When replacing the batteries ----- Red and green LED both on.

2. When green LED goes off
----- (Remaining time)

Manganese battery: Approx 20 mins

Alkaline battery: Approx 45 mins

Nicd battery: Approx 0.5 min

! After the red LED starts to flash, change the batteries. (Charge the Nicd battery.)

* Consider the remaining time (time until the red LED starts to flash) as an approximate time. The actual time depends on the battery used, environment, and other conditions.

CHANGING THE NEUTRAL POSITION

(Change only when necessary)

* Change the neutral position only when large forward stroke of the throttle stick is needed when using an FET E.S.C., etc. (The neutral position is set to the center at the factory.)

* The front case is held by four hooks. Open the front case as described next, then change the neutral position of the throttle stick.

* If the battery is in the transmitter, remove it beforehand.

* Also remove the antenna.

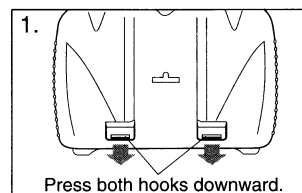

1. Slide the case off while pressing the two hooks at the bottom rear of the transmitter simultaneously with your fingers. (If the case is forced open in this state, it may be damaged.)

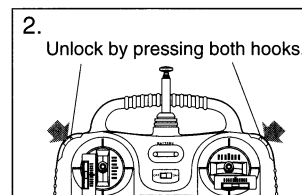

2. Unlock the lock and open the front case while pressing the two hooks at the top of the transmitter simultaneously with your fingers.

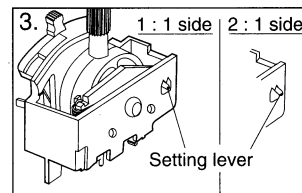

3. Move the setting lever at the throttle stick body to the outside. This moves the throttle stick neutral position to the 2:1 side.

4. When closing the front case, push in the four front case hooks, while being careful that the trim levers, switches, and LEDs do not get caught, until they lock with a click.

* However, when returning from the 2:1 to the 1:1 position (neutral center), return the setting lever to the 1:1 side with the stick lever pushed to the HI side. Otherwise, the setting lever cannot move.

TWO-SERVO SET CONNECTIONS

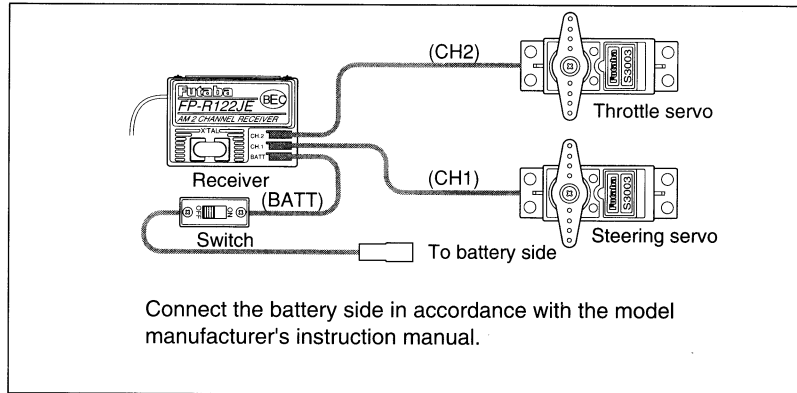

CONNECTION OF SET WITH FET E.S.C.

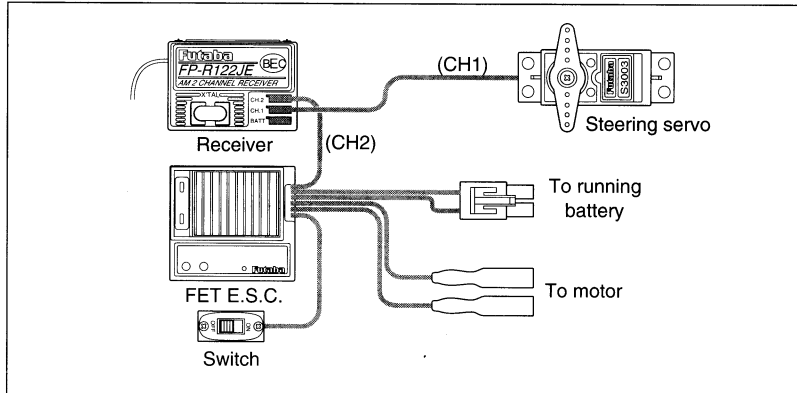

ADJUSTMENTS

! Do not connect the running motor when making the settings described here.

INSTALLING THE SERVO HORN

1. Connect the receiver, servos, etc. and turn on the transmitter and receiver power switch.
2. Set the transmitter trim lever to the center position.
(The servos move to the neutral position.)

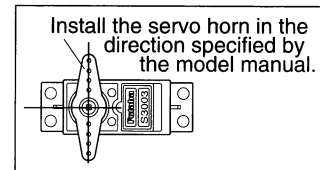

3. In this state, install the servo horn in the direction specified by the model manual.

REVERSING THE SERVO DIRECTION OF TRAVEL

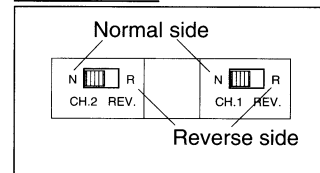

When the direction of travel of a servo is opposite the direction specified by the model manual, it can be reversed with the reversing switch. The reversing switches can be accessed by sliding the battery cover open.

FET E.S.C. ADJUSTMENT

* Adjust the FET E.S.C. with the miniature screwdriver supplied with the set.

(Preparations)

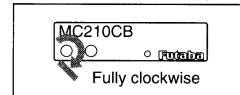

1. Set the transmitter throttle reversing switch to the "N" (normal) position.
2. First, turn the HI point trimmer fully clockwise.

(Neutral adjustment)

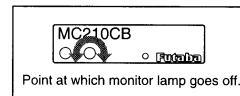

1. Set the throttle stick to the neutral position.
2. Set the neutral trimmer to the point at which the monitor lamp goes off. (The point at which the lamp switches from a fast flashing to off is the neutral point.)

(Hi point adjustment)

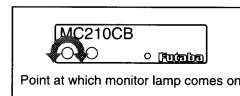

1. Hold the throttle stick in a position just before the maximum speed position.
2. Set the HI point trimmer to the point at which the monitor lamp comes on.

(The point at which the monitor lamps switches from a fast flashing to a steady light is the HI point.)

(MONITOR LAMP DISPLAY)

Reverse side :	Slow flashing
Neutral point :	Off
Forward side :	Fast flashing
HI point :	On

USING OPTION PARTS

MODIFYING THE THROTTLE STICK TO A RATCHET TYPE

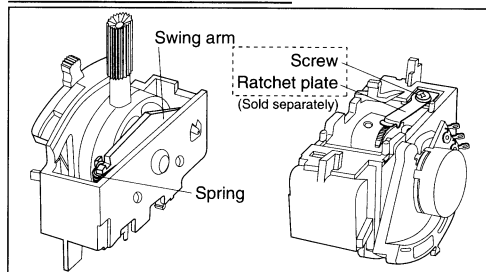

Open the transmitter front case and modify the stick section. (For a description of how to open the case, see the "PREPARATIONS" section of this manual.)

* The ratchet plate (sold separately) is necessary for this modification.

1. Remove the spring and swing arm.
2. Install the ratchet plate with the screw.

Digital Proportional Frequency (for U.S.A.)

* The frequency of Futaba digital proportional sets can be changed within their own band. There are 2 different bands for you to choose from 27 MHz and 72-75 MHz. Please see chart listed below for specific frequency and its intended use. Please note there are specific frequencies allocated for aircraft only and surface only use.

* The frequency can be changed within the same BAND. However, Futaba recommends that you return your system to our factory service department for frequency changing, as tuning may be necessary for proper operation. Changing frequency from one band to another is NOT possible.

Always change frequency flag when frequency is changed. The frequency flag is to be attached to the top of antenna and the channel designation to the base. (See Drawing)

* It is illegal to change crystals on 72-75 MHz bands in the U.S.A. unless performed by a licensed technician.

(Antenna frequency flag)

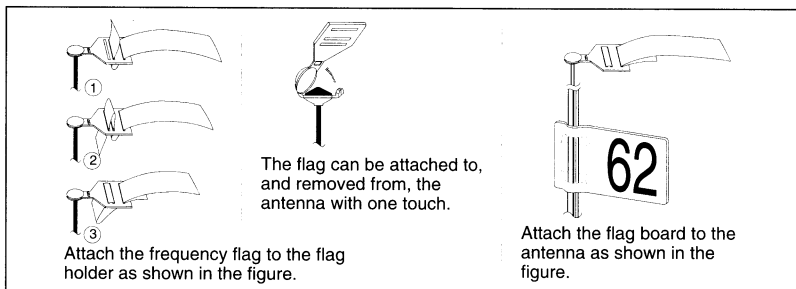

(Frequency, Channel No. Flag Color for U.S.A.)

26-27MHz-Aircraft/car/boat

Color	Color
26.995 Brown	27.145 Yellow
27.045 Red	27.195 Green
27.095 Orange	27.255 Blue

50/53 MHz-Aircraft/car/boat-Fcc Amature Licence required

(2 and 3 channels not produced on these frequencies).

Channel No.	Color
50.800 RC00	53.100 Black-Brown
50.820 RC01	53.200 Black-Red
50.840 RC02	53.300 Black-Orange
50.860 RC03	53.400 Black-Yellow
50.880 RC04	53.500 Black-Green
50.900 RC05	53.600 Black-Blue
50.920 RC06	53.700 Black-Violet
50.940 RC07	53.800 Black-Gray
50.960 RC08	
50.980 RC09	

72MHz-Aircraft only

72.010 11	72.210 21	72.410 31	72.610 41	72.810 51
72.030 12	72.230 22	72.430 32	72.630 42	72.830 52
72.050 13	72.250 23	72.450 33	72.650 43	72.850 53
72.070 14	72.270 24	72.470 34	72.670 44	72.870 54
72.090 15	72.290 25	72.490 35	72.690 45	72.890 55
72.110 16	72.310 26	72.510 36	72.710 46	72.910 56
72.130 17	72.330 27	72.530 37	72.730 47	72.930 57
72.150 18	72.350 28	72.550 38	72.750 48	72.950 58
72.170 19	72.370 29	72.570 39	72.770 49	72.970 59
72.190 20	72.390 30	72.590 40	72.790 50	72.990 60

75 MHz-Car/boat only

75.410 61	75.610 71	75.810 81
75.430 62	75.630 72	75.830 82
75.450 63	75.650 73	75.850 83
75.470 64	75.670 74	75.870 84
75.490 65	75.690 75	75.890 85
75.510 66	75.710 76	75.910 86
75.530 67	75.730 77	75.930 87
75.550 68	75.750 78	75.950 88
75.570 69	75.770 79	75.970 89
75.590 70	75.790 80	75.990 90

RATINGS

TRANSMITTER FP-T2CR

Operating system	Two-stick
Transmitting frequency	26, 27, 29, 40, 41, 72, or 75MHz band
Modulation	AM (Amplitude Modulation)
Power requirement	12V (8 penlight batteries or 8 Ni-cd batteries)
Current drain	160mA

RECEIVER FP-R122JE / FP-R112JE

Receiving frequency	26, 27, 29, 40, 41, 72, or 75MHz band
Power supply voltage	4.8 to 8.4V (BEC built-in)
Current drain	30mA (4.8V), 10mA (8.4V) (no signal)
Dimensions	47.2x33.3x17.3mm / 47.6x31.5x15.7mm (1.86x1.31x0.68in / 1.87x1.24x0.62in)
Weight	16.6g / 20.5g (0.59oz / 0.72oz)

SERVO FP-S3003

Control system	Pulse width control
Power requirement	4.8V or 6V (shared with receiver)
Current drain	8mA/6V (at idle)
Output torque	3.2kg-cm (44.4oz-in)
Operating speed	0.23sec/60degree
Dimensions	40.4x19.8x36mm (1.59x0.78x1.42in)
Weight	37.2g (1.31oz)

FET E.S.C. MC210CB/MC310CB

Voltage drop	Approx 0.52V/0.41V (at 20A) (between E.S.C. input and output)
Maximum current	30A/35A (fuse capacity)
Power requirement	7.2 to 8.4V
Regulator output(6V)	(210CB)3A max (310CB) 1A max (7.2V input), 0.5A max (8.4V input)
Dimensions	45.5x41.5x26mm (1.79x1.63x1.02in)
Weight	72.5g / 78g (2.56oz / 2.75oz)

WHEN YOU THINK THE SET IS FAULTY

When the R/C set does not operate at all, the receiving range is short, or the R/C set operates intermittently or operates erroneously, first check the following items:

* However, when the model does not run straight in neutral, takes off in neutral, or does not run fast when the throttle stick is set to maximum speed even when the trim lever are adjusted, recheck the "ADJUSTMENT" section of this manual.

Part	Check item	Remedy
Transmitter/receiver batteries	Dead battery	Change the batteries.
	Incorrect loading	Reload the batteries.
	Faulty contact	Correct the shape of the spring.
	Dirty contact	Wipe the contacts with a dry cloth.
Transmitter antenna	Disconnection	Screw in the antenna.
Transmitter/receiver crystal	Missing	Insert the crystal.
	Wrong frequency	Match the transmitter and receiver frequency.
Receiver/servo connectors	Incorrect wiring	Switch the wiring.
	Disconnection	Reconnect the connector.
Receiver antenna/wiring to receiver	Motor or other part that carries a large current is near the wiring	Separate the wiring from other parts.
Motor	Noise suppressing capacitors not installed	Install noise suppressing capacitors.
FET E.S.C.	Blown fuse	Replace the fuse. (*1)
	Heat protector operation	Remove the cause/wait until cool.

(*1) Observe the fuse capacity. (30A/MC210CB, 35A/MC310CB)

REPAIR SERVICE

Before requesting repair, please refer to this instruction manual again and verify your settings. If you are still experiencing trouble, please request service as follows:

(Address)

Your nearest Futaba dealer.

(Repair information)

Describe the trouble in as much detail as possible.

- 1) Symptom: Including the state of the set when the trouble occurred.
- 2) Digital proportional set used: Transmitter, receiver, and servo model numbers.
- 3) Vehicle: Vehicle name and mounting conditions.
- 4) Your name, address, and telephone number.

(Warranty contents)

Read the warranty card supplied with your set.

*The warranty contents differ with geographic locations.



FUTABA CORPORATION

Makuhari Techno Garden Bldg., B6F 1-3 Nakase, Mihama-ku, Chiba 261-01, Japan
Phone: (043) 296-5119 Facsimile: (043) 296-5124

FUTABA CORPORATION OF AMERICA

4 Studebaker, Irvine California 92718, U.S.A.
Phone: 714-455-9888 Telex: 23-0691227 Facsimile: 714-455-9899