

Rapide



Rx-R
RECEIVER-READY

INSTRUCTION MANUAL

SPECIFICATIONS

Wingspan:	60 in [1525 mm]	Wing Loading:	17 oz/ft ² [52 g/dm ²]	Motor: 35 x 41 mm, 130g 950 kV outrunner, 13.5 x 7 folding propeller, 40A programmable ESC w/5V 3A switching BEC
Wing Area:	364 in ² [23.5 dm ²]	Length:	42.5 in [1080 mm]	
Weight:	2.75 lb [1250 g]	Radio:	4-6 channel	

WARRANTY

Flyzone® guarantees this kit to be free from defects in both material and workmanship at the date of purchase. This warranty does not cover any component parts damaged by use or modification. In no case shall Flyzone's liability exceed the original cost of the purchased kit. Further, Flyzone reserves the right to change or modify this warranty without notice.

In that Flyzone has no control over the final assembly or material used for final assembly, no liability shall be assumed nor accepted for any damage resulting from the use by the user of the final user-assembled product. By the act of using the user-assembled product, the user accepts all resulting liability.

If the buyer is not prepared to accept the liability associated with the use of this product, the buyer is advised to return this kit immediately in new and unused condition to the place of purchase.

For warranty claims Contact Hobbico Product Support:

Hobbico Product Support
3002 N. Apollo Drive Suite 1
Champaign IL 61822 USA
Telephone: (217) 398-8970 ext. 6
Fax: (217) 398-7721
E-mail: airsupport@hobbico.com

READ THROUGH THIS MANUAL BEFORE STARTING CONSTRUCTION. IT CONTAINS IMPORTANT INSTRUCTIONS AND WARNINGS CONCERNING THE ASSEMBLY AND USE OF THIS MODEL.

Flyzone[™]
how high will you soar

Champaign, Illinois
(217) 398-8970
E-mail: airsupport@hobbico.com

TABLE OF CONTENTS

INTRODUCTION	2	Motor Thrust Angle Adjustment	8
ADDITIONAL ITEMS REQUIRED	2	Tail Servos	8
For Optional Flaps	2	ESC Programming Instructions	9
ASSEMBLY	3	ESC Specifications	9
Install the Horizontal Stabilizer	3	ESC Programming Options	9
Install the Wing	3	Throttle Calibration	9
Final Assembly	4	Motor Start Procedure	9
SET THE CONTROL THROWS	5	FULL PROGRAMMING INSTRUCTIONS	9
CHECK THE FAILSAFE	5	Automatic Throttle Cutoff Protection	10
MOUNT THE PROPELLER	6	ESC TROUBLESHOOTING GUIDE	11
CHECK THE CENTER OF GRAVITY	6	SAFETY PRECAUTIONS	11
SET A FLIGHT TIMER	7	Motor Safety Precautions	12
FLYING	8	AMA	12
Motor Data	8	KNOW BEFORE YOU FLY	12
Hand-Launch	8	REPLACEMENT PARTS	12
Flying	8	Optional: Hook Up the Flaps	12
Landing	8		

INTRODUCTION

Thank you for purchasing the FlyZone Rapide. The Rapide is an ideal first “speedy” airplane because it’s stable, large and easy to see, but still fast enough to get that speed addiction going and impress your flying buddies and spectators at your local site.

For the latest technical updates or corrections to the instruction manual, scan the QR code below, or visit the **Flyzone** web site at www.flyzoneplanes.com. Click the *airplane* icon at the top of the page, then find and select *Rapide*. Click the **“Parts & Tech Info”** link on the right side of the page. Any notices or manual corrections are viewable by clicking the “Tech Notice” link at the bottom of the page.



ADDITIONAL ITEMS REQUIRED

- 4-6-channel transmitter (Tactic TTX650; TACJ2650)
- 4-6-channel receiver (Tactic TR625; TACL0625)
- 2200mAh 3S LiPo with *Star* or compatible connector (GPMP0861 or FPWP3223)
- Suitable LiPo charger such as the Great Planes Electrify Triton EQ AC/DC Charger (GPMM3155)
- Great Planes Pro Threadlocker (GPMR6060)



- A 1.5mm hex driver is required for tightening the 3mm set screws in the propeller yoke. A quality, machined, hardened steel hex driver is **strongly recommended** for this job to make sure the propeller hub is securely fastened to the motor shaft.



Do not mount the propeller until instructed to do so!

For Optional Flaps

Flaps are optional and not necessary, but may be added to your Rapide to slow the model and shorten the landing approach. The following items are required to set up your Rapide with flaps:

- Rapide flap linkage kit (FLZA6673)
- (2) Micro servos (TSX5 TACM0205)
- (2) 12" [300mm] servo extensions (TACM2093)
- Y-harness/dual servo extension (FUTM4130)
- Glue for servos (Shoe Goo, DTXC2460)
- Medium CA (GPMR6007)
- Clear tape

ASSEMBLY

Install the Horizontal Stabilizer

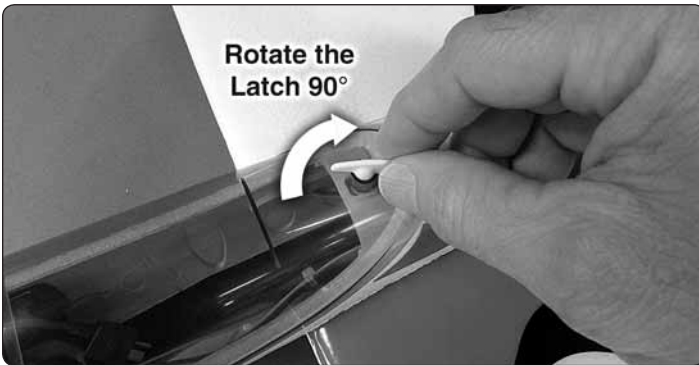

- ❑ 1. To remove the canopy; simply rotate the latch 90-degrees to either side, then lift the back of the canopy.

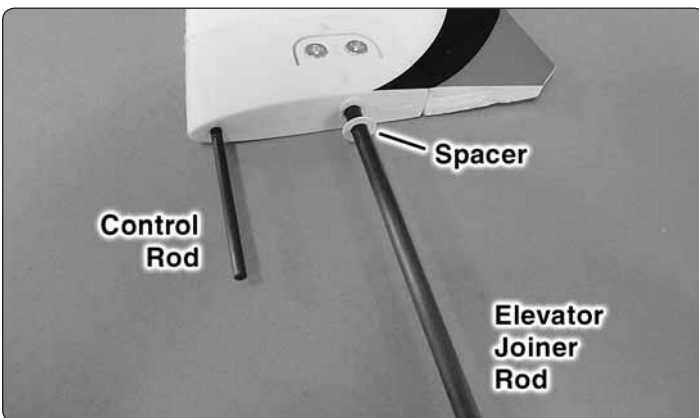

- ❑ 2. Fit the **elevator joiner rod** and the **control rod** into one of the **horizontal stabilizer** halves and install a thin, plastic **washer spacer** onto the joiner rod.

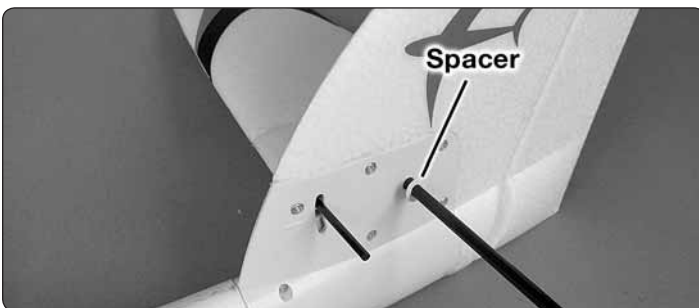
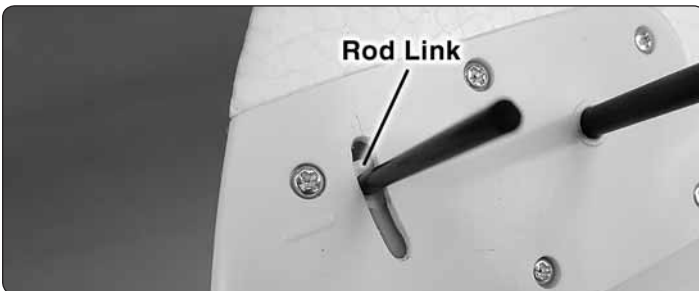

- ❑ 3. Install the assembly into the vertical stab making certain the control rod is through the **rod link** on the end of the pushrod inside. Install another washer spacer onto the joiner rod.

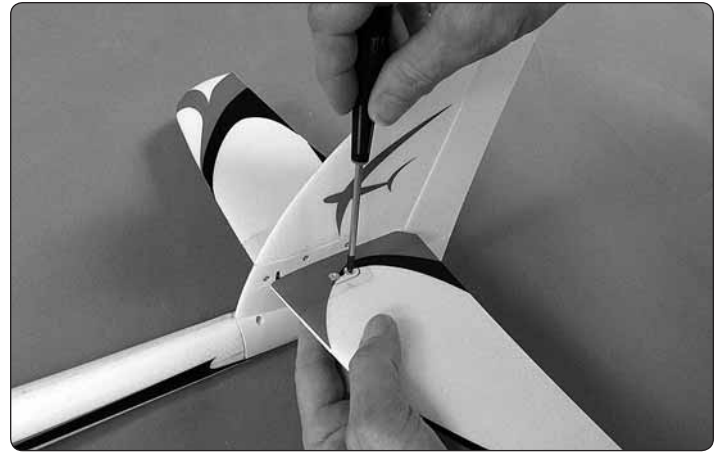

- ❑ 4. Join the other stab half to the assembly, then secure both stab halves to the joiner rod by tightening the screws.

If you will be installing optional flaps, proceed to "Optional: Hook Up the Flaps" on page 12. If you won't be installing flaps now, but decide to use flaps in the future, flaps may be installed at any time.

Install the Wing

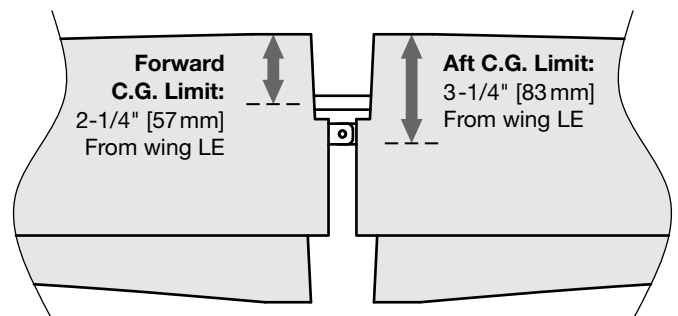

- ❑ 1. Temporarily fit the wings together with the wing joiner and mark the C.G. range on the bottom of both wings 2-1/4" and 3-1/4" [57mm and 83mm] from the leading edge—the lines can be marked on tape applied to the bottom of the wing, or directly on the wing.

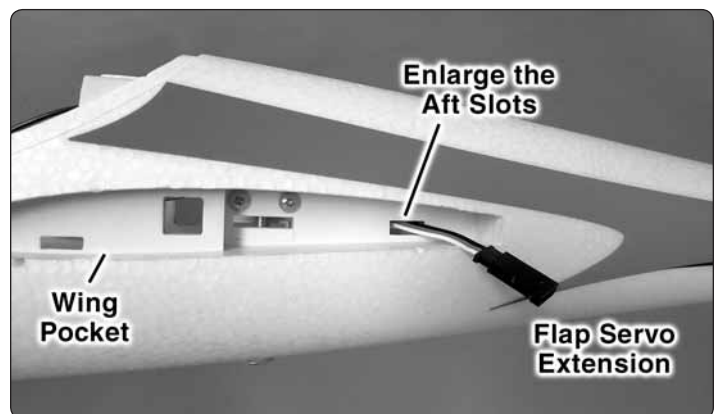

- ❑ 2. If you've installed flap servos, use a hobby knife to carefully enlarge the aft slots in the wing pockets to pass the male receptacle on the flap servo wire extensions. Guide two 12" [300mm] extensions in through the slots with the male end sticking out as shown.

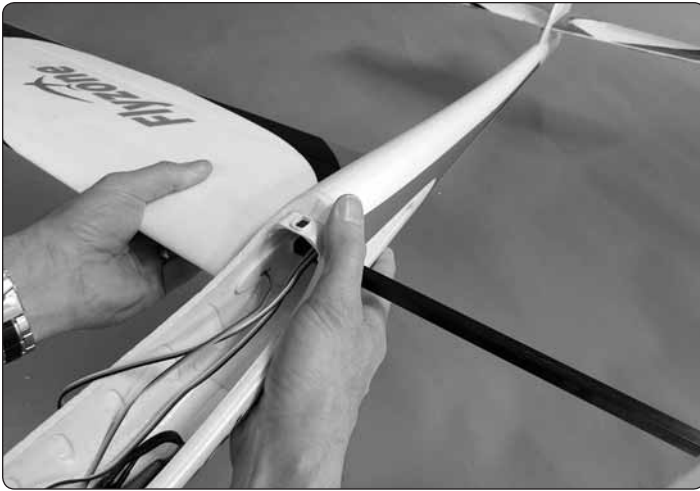

❑ 3. Fit one of the wings to the fuselage with the **wing joiner** while guiding the aileron servo wire through the forward slot in the wing pocket. Connect the flap servo—if used—to the servo extension coming from the rear slot. Fit the wing all the way into the pocket making sure none of the wires get pinched on the end of the wing.

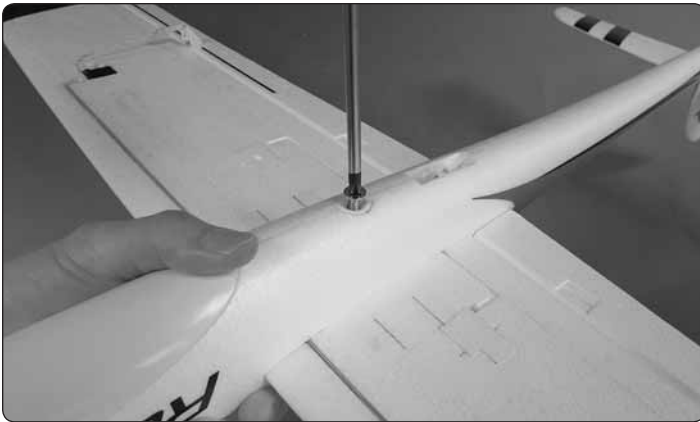

❑ 4. Fit the other wing to the fuselage. Secure the wings with the M6×55 wing bolt.

Final Assembly

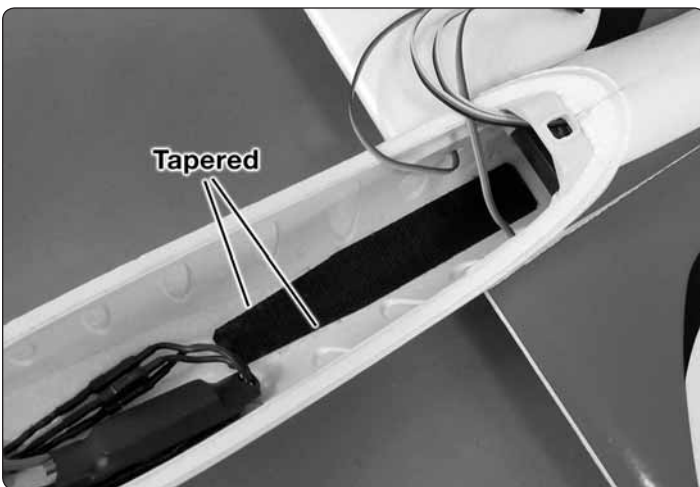

❑ 1. Use a straightedge and a hobby knife to cut a slight taper to the rougher, “hook” side of the included Velcro strip to fit the bottom of the fuselage as shown, then stick it into position.

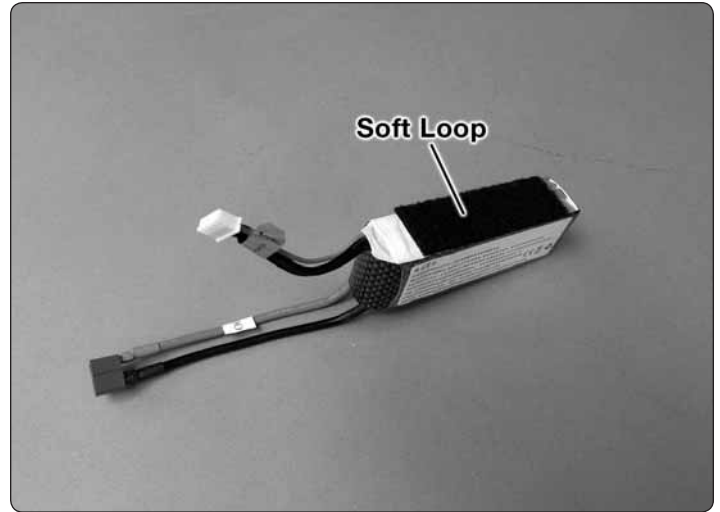

❑ 2. Apply a strip of the softer, “loop” side of the Velcro strip to the surface of the battery shown.



Refer to this photo for the following two steps.

❑ 3. Mount the receiver to the inside of the fuselage with the included Velcro strip or double-side foam mounting tape (not included). Connect the servo wires to the receiver, then consolidate all the wires as best you can to facilitate battery removal and installation—we used small tie wraps to gently bundle the wires together.

❑ 4. Test-fit the battery in the fuselage as shown. Note that the power leads from the battery are in the rear to take up slack so that the wires will not contact the motor. Use tape, tie wraps or any other suitable method to make certain **none** of the wires inside the fuselage will come into contact with the turning motor while the plane is flying.

SET THE CONTROL THROWS

CAUTION: The propeller should still not be installed.

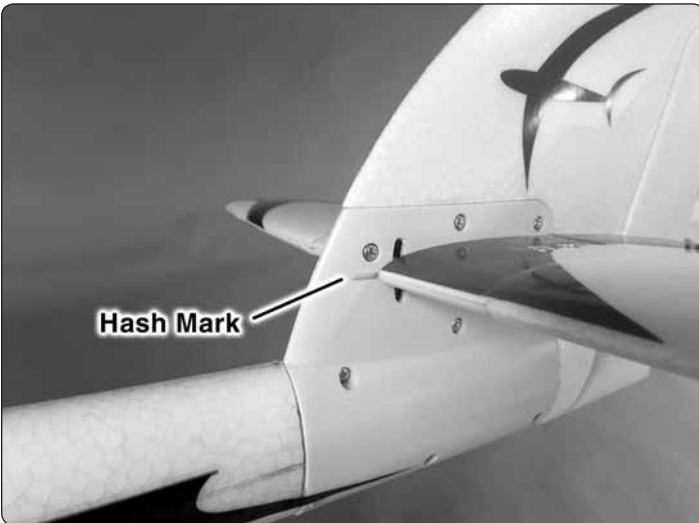
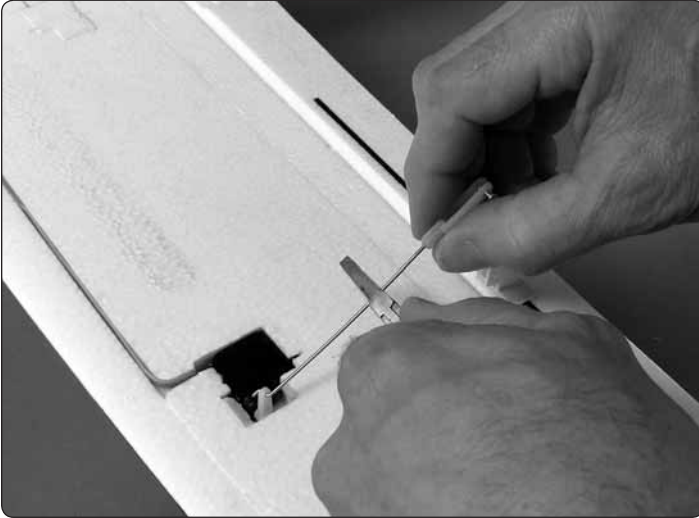

❑ 1. Make sure the motor and control surfaces respond in the correct direction to transmitter inputs. If necessary, adjust the length of the pushrods or use sub trims to center the control surfaces (the elevator is centered when the leading edge aligns with the molded-in *hash* marks).

Note: If the motor beeps or doesn't turn when you advance the throttle, the throttle setting in the ESC may need to be calibrated. See **Throttle Calibration** instructions on page 9.

❑ 2. Measure and set the control throws as specified in the chart. If balanced within the recommended C.G. range, the Rapide is stable and forgiving, so absolute precision is not required when setting and measuring your throws. But starting at the throws provided (or $\pm 1/16$ " [1.5 mm] of the throws) will give you a good starting point.



NOTE: The control throws are measured at the **widest** part of each surface; at the bottom of the rudder and the *root*, or inboard ends of the elevators, ailerons and flaps (if installed). And though the root ends of the ailerons will be narrower if you've cut them from the flaps, the throw measurements provided are still applicable because the difference is insignificant.

These are the recommended control surface throws:

	LOW		HIGH	
	Up	Down	Up	Down
ELEVATOR	1/4" [6mm] 6°	1/4" [6mm] 6°	3/8" [10mm] 9°	3/8" [10mm] 9°
AILERON	1/2" [13mm] 17°	3/8" [10mm] 12°	5/8" [16mm] 21°	1/2" [13mm] 17°
RUDDER	5/8" [16mm] 16°	5/8" [16mm] 16°	7/8" [22mm] 22°	7/8" [22mm] 22°
FLAPS	1/2 Rate 1/2" [13mm] 17°		Full Rate 1" [25mm] 34°	

CHECK THE FAILSAFE

Read the instructions that came with your radio control system to set and check the **Failsafe** function. Failsafe should be set so that power to the motor is automatically cut in the event that the receiver loses signal (say, due to a radio malfunction, or if you inadvertently turn off the transmitter before disconnecting power from the receiver).

❑ 1. To do a quick failsafe check, **still without the propeller mounted**, power up your transmitter and receiver so you can operate the throttle. Advance the throttle enough to make the motor turn, then turn off the transmitter (to create a condition

where the receiver is not receiving a signal). If the Failsafe is set correctly the motor will stop turning.

❑ 2. If the motor **doesn't** stop when you turn off the transmitter, the receiver may need to be re-linked to the transmitter to re set the failsafe. Follow the procedure in the instruction manual that came with your transmitter to reset the Failsafe.

MOUNT THE PROPELLER

We've not found it necessary to balance the included propeller, but pilots who demand the most performance may balance the propeller. In any case, if you ever detect unusual noise or vibration from the prop or motor, do not fly the plane, or land the plane and find the source of the problem.

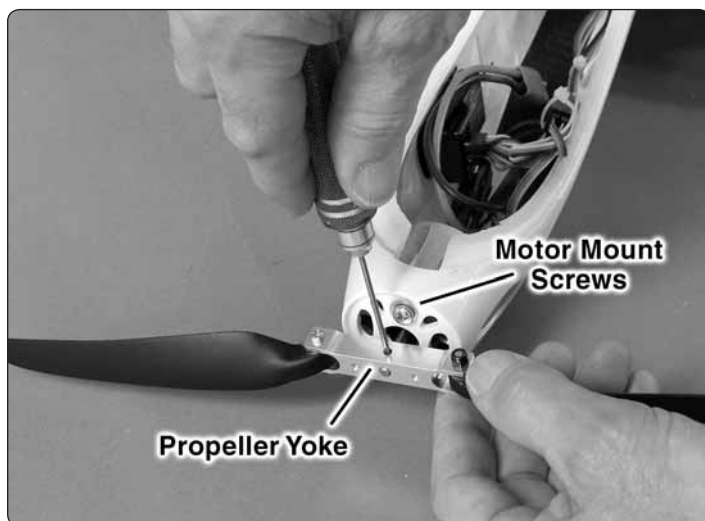

❑ 1. Use a precision 1.5 mm hex driver to fasten the propeller yoke to the motor shaft with both M3 set screws and threadlocker—make certain the set screws *land* on the flat spots on the motor shaft and make sure the propeller yoke does not contact the motor mount screws.



❑ 2. Mount the spinner to the yoke with two 3 x 8 mm Phillips screws with threadlocker on the screws.

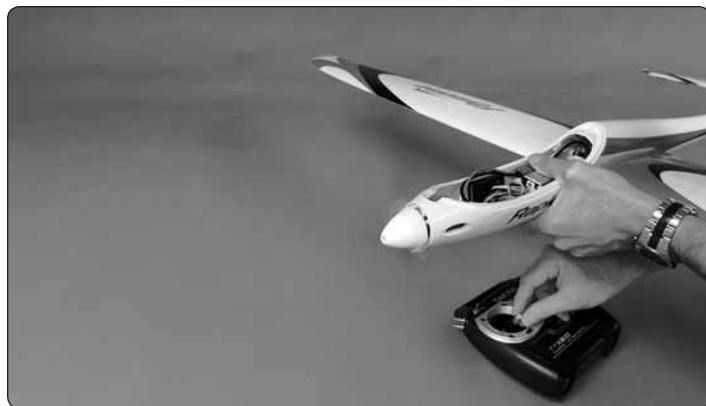

❑ 3. Now that the propeller is mounted, power up your plane and make sure the motor **brake** is activated so the propeller abruptly stops when you cut the throttle; Advance the throttle stick to turn the motor at a low rpm, then lower the throttle to stop the motor. If the propeller abruptly stops the brake is properly activated. If the motor gradually coasts to a stop, set the motor brake using the ESC programming instructions on page 9.

CHECK THE CENTER OF GRAVITY

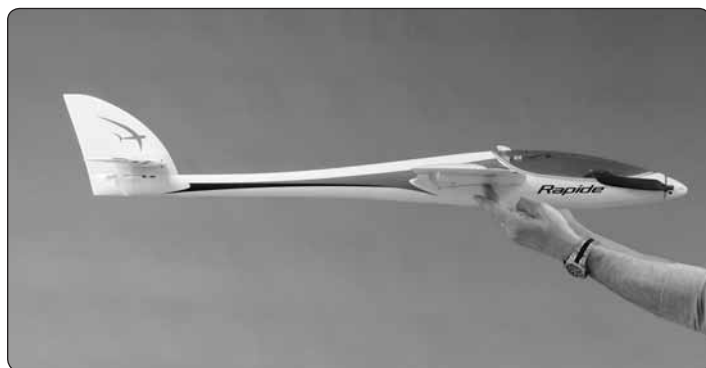

❑ 1. Install a battery and the canopy. Lift the model and position the wing on your fingertips until the model rests level. If your fingers are between the balance lines you marked earlier, your Rapide is balanced within the acceptable range.

❑ 2. If the Rapide does not balance correctly, shift the battery forward or aft or add ballast to the nose or tail to get it to balance—the Rapide should balance with no additional ballast if using a recommended 3S 2200 mAh battery.

SET A FLIGHT TIMER

To protect your batteries (and potentially your airplane if you discharge a battery down too far to keep the plane airborne), limit your flying time with a timer set to a pre-calculated time instead of waiting for the LVC (low voltage cutoff) in your ESC to activate or until you notice a decrease in flight performance.

Flying aggressively, the *minimum motor run time* for the Rapide is approximately 3 minutes, so start conservatively by setting your timer there. If your transmitter has a timer, link the timer to the throttle stick (so only motor run time will be counted). Otherwise, you'll have to use an external timer (which will count total air time).

When your timer sounds, land, then note the time on your timer. Charge your battery and note how much capacity it required to recharge the pack (indicating how much capacity was used during the flight). Divide the capacity that went back into your battery by the flight time to calculate the average discharge rate per-minute. Divide 80% of your battery's capacity by this rate to determine approximately how long you should fly.

You can use this worksheet to record flight times and recharge capacity to calculate target flight time. Row #1 is filled out with an example:



Note: If you don't have a charger with a readout indicating how much capacity went back into the pack, you can use a battery checker (GPMM3205) to check the resting, unloaded voltage of your pack. This target voltage is 3.7 Volts per cell. If the voltage per cell is higher you can fly longer and if it's lower you should shorten your flight time.

	A	B	C	D	E	F	G
	FORMULAS	A x .8			D / C	B / E	(D/1000)/(C/60)
	Battery Capacity	Target Capacity to Use in Flight	Flight Time (in 10ths)	Recharge Capacity	mAh/minute	Recommended Flight Time	Avg. In-Flight Current
1	2200 mAh	1760 mAh	3.5 min	1630 mAh	465 mAh/min	3.8 min	28 A
2							
3							
4							
5							
6							
7							
8							
9							
10							

FLYING

Motor Data

The Rapide is equipped with a 950kV 130g motor, 40A ESC and 13.5 x 7 folding propeller. This setup draws approximately 45 Amps/500 Watts static. Airborne, momentary current peaks reach up to approximately 37A/410W (while the motor is briefly loaded at the apex of a vertical climb or a tightly-banked pylon turn). Flying full-throttle the entire flight, the current draw averages about 26A/250W.



CAUTION: Never run the motor at full-throttle on the ground (static – not flying) for more than 5 – 10 seconds. Otherwise, the high current draw could cause the motor or the ESC to overheat.



Also note that replacing the included propeller with one that makes the Rapide fly faster could cause the motor to draw more current than the motor or ESC can withstand and/or cause potential aerodynamic problems with the airframe.

Hand-Launch

The Rapide can be easily self-launched by the pilot, but less-experienced pilots may benefit from the assistance of another pilot to launch it for the first time. Simply grasp the Rapide by the bottom of the fuselage under the wing and throw it directly into the wind at a slightly upward angle at full-throttle.

Flying

The Rapide is stable on the roll axis, so we almost always prefer the ailerons set to high rates, but for high-speed flying we set the rudder and elevator to low rates. For slower, less aggressive flying, or when landing, high rates on all controls is preferred.

The Rapide exhibits no adverse flight characteristics that you need to be aware of. You can pretty much just “put the pedal to the metal” and do with it what you will. In *high-G* situations you may notice the wings flex a bit, but the Rapide can take it.

One exercise to practice before landing is to learn the Rapide’s stall characteristics—how it reacts when it stalls and how it behaves just before. With plenty of battery and lots of altitude, cut the throttle and gradually feed Up elevator as the Rapide continues to slow and finally stalls. Resume control, apply power, regain altitude and try it again. Do this a couple of times so you’ll know how slow the Rapide can fly and what it will do just before it stalls. Make a mental note so you can avoid this envelope when actually ready to land.

Landing

If you’re not already used to sleek, low-drag airplanes, you may find that the Rapide takes considerably more distance to land, so you’ll need to cut power earlier and make your approaches from farther out. Well before your battery gets too

low, begin practicing landing approaches so you can throttle up and go around again if necessary. Test the Rapide’s reaction to flaps (if installed) – you’ll notice it balloons initially, but after it slows this reaction will dissipate. You still may want to add a little down elevator mix to flaps to level the nose. Practice approaches (using flaps if desired). If you get an approach that’s too long, simply retract the flaps, throttle up and go around again. After landing, always unplug the flight battery first before turning off the transmitter.

Motor Thrust Angle Adjustment



The motor thrust angle is adjustable to suit different propellers. Different propellers may require different degrees of right thrust – especially during a vertical climb. Drastic C.G. changes may also require changes in up/down thrust.

To adjust the motor thrust angle, remove the spinner and loosen the two screws that hold the motor mount to the fuselage. Adjust the motor as required, apply threadlocker then retighten the screws and attach the spinner.

Tail Servos

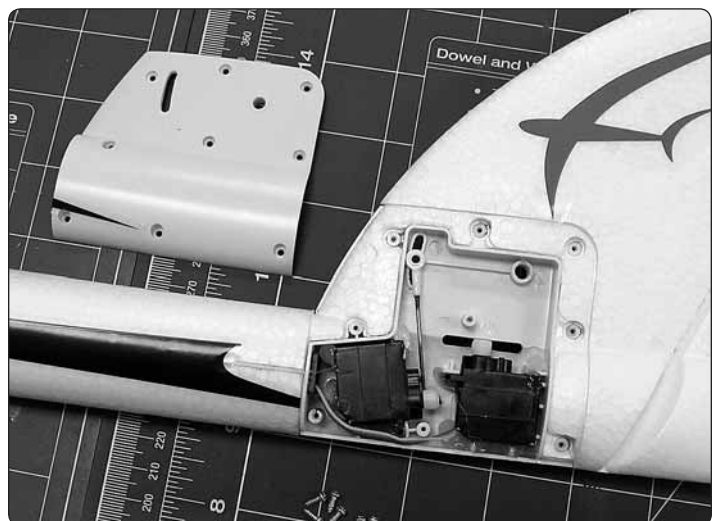

If you were curious to see what the inside of the tail looks like and how the servos are installed, here’s a photo so you can see without having to remove the cover.

ESC Programming Instructions

Most modelers will never alter the ESC programming, but for those interested, or if the ESC will ever be transferred to a different model with different requirements, following are the full ESC programming instructions.

ESC Specifications

- BEC:** 40A switching
- Constant current:** 40A
- Burst current:** 55A (max. 10 seconds)
- BEC output:** 5V/3A, 5 servos
- LiPo cells:** 2-4S

The ESC included with your Rapide is programmed to these settings:

- Brake:** On
- Battery Type:** LiPo
- Cut-off mode:** Soft
- LiPo cutoff voltage:** Medium (3.15V/cell)
- Motor start power**
 - (Start Mode):** Normal (300 milli-seconds)
 - Timing:** Low (3.75°)

ESC Programming Options

1. **Brake:** (On/off)
2. **Battery Type:** (LiPo/NiMH)
3. **Cut-off mode:** (Soft/Normal)
- 4A. **LiPo cutoff voltage:** (Low [2.85V/cell]
Medium [3.15V/cell]
High [3.3V/cell])
- 4B. **NiMH cutoff voltage:** Disabled
Medium [50% of initial voltage]
High [65% of initial voltage])
5. **Motor start power:** Start Mode
Normal [300 milli-seconds]
Soft [1.5 seconds]
Super-Soft [3 seconds]

Normal is suitable for most fixed-wing aircraft. **Soft** or **Super-soft** are for helicopters; Initial motor start for Soft and Super-Soft is slower (1.5 second for Soft start and 3 seconds for Super-Soft start from initial throttle advance to full throttle). If the throttle is completely closed and advanced again within 3 seconds, the re-start will be temporarily changed to **Normal** to eliminate an accident due to slow throttle response.

6. **Timing:** Low [3.75°]
Medium [15°]
High [25°]

Low timing is suitable for most motors. For increased rpm the timing may be advanced, but this may cause the motor or ESC to get too hot.

Throttle Calibration

In some instances the throttle may require **calibration** so the ESC can detect the high and low endpoints of your throttle stick. Recalibration may be required if you ever switch to a different transmitter or if you adjust the throttle end points in the transmitter you are using. **Remove the propeller before proceeding.**

1. Turn on the transmitter and advance the throttle to the “up” position.
2. Connect the battery to the ESC; Hear a chime (“♫ 1 2 3”), followed by two beeps (“beep beep”) indicating that the ESC has read the top of the throttle range.
3. Move the throttle stick to the low position and again; Hear three more beeps (“beep beep beep”) indicating the number of LiPo cells the ESC has detected, followed by a single longer beep (“beep”) indicating that the ESC has read the bottom of the throttle range. Now the throttle has been calibrated.

Note: If this procedure does not work, increase or decrease the low throttle trim or throttle end point on your transmitter, then repeat the procedure.

Motor Start Procedure

Here's how to start the motor:

1. Lower the throttle stick, then turn on the transmitter.
2. Connect the battery to the ESC; Hear the confirmation chime (“♫ 1 2 3”) indicating that the power supply is okay, followed by three more beeps (“beep beep beep”) indicating the number of LiPo cells the ESC has detected followed by a single, longer beep (“beep”) indicating that the ESC is armed and ready to fly.



CAUTION: Now the motor will turn when the throttle is advanced.

FULL PROGRAMMING INSTRUCTIONS

Caution: The procedure of programming the ESC will not cause the propeller to turn, but should the user unknowingly exit programming mode the motor could unexpectedly turn. Because of the potential for user error, **it is advisable to remove the propeller when programming the ESC.**

1. Follow the procedure to enter **Programming Mode:**
 - A. Turn on the transmitter. Advance throttle stick all the way.
 - B. Connect the battery to the ESC:
Hear the chime (“♫ 1 2 3”) followed by:
Two short beeps (“beep beep”) followed by:
5-second pause followed by:
Another chime (“♫ 1 2 3 4 5”)

The ESC is now in Programming Mode and will loop through a sequence of beeps representing a function in the menu that can be reprogrammed. (You don't have to do anything at this time; you can simply listen to the beeps identifying which function correlates to which sequence of beeps.)

	PROGRAMMING MENU	INDICATOR	FUNCTION
1	One short beep	“beep”	Brake
2	Two short beeps	“beep beep”	Battery Type
3	Three short beeps	“beep beep beep”	Cutoff Mode
4	Four short beeps	“beep beep beep beep”	Cutoff Voltage
5	One long beep	“beep”	Start Mode
6	One long beep, one short beep	“beep beep”	Timing
7	One long beep, two short beeps	“beep beep beep”	Set the ESC to Default
8	Two long beeps	“beep beep”	Exit Programming

2. After hearing the sequence of beeps representing the desired function, **lower** the throttle stick to enter the programming mode for that function. The ESC will beep as indicated below waiting for your command to change the setting:

	FUNCTION	1 BEEP	2 BEEPS	3 BEEPS
1	Brake	Off	On	
2	Battery Type	LiPo	NiMh	
3	Cutoff Mode	Soft	Hard	
4	Cutoff Voltage	Low (2.85 V)	Medium (3.15 V)	High (3.3 V)
5	Start Mode	Normal	Soft	Super Soft
6	Timing	Low (3.75°)	Medium (15°)	High

Advance the throttle after number of beeps (one beep, two beeps, three beeps) indicating the new setting. Hear the chime (“♫ 1 2 1 2”) indicating the value has been set and saved. Immediately lower the throttle stick (within two seconds) to exit programming mode preceded by the number of short beeps counting the number of LiPo cells, followed by one long beep (“beep”) indicating the model is ready to fly. Or, disconnect battery at any time to exit programming mode.

If the throttle stick is left in advanced programming mode, programming will resume where it left off—simply listen for the sequence of beeps that represents the next function, then lower throttle stick to enter the programming mode for that function.

Example:

To set brake from the factory default of “off” to “on”:

- 1. Advance the throttle stick. Turn on the transmitter.
- 2. Connect battery.
Hear the chime (“♫ 1 2 3”) followed by:
Two short beeps (“beep beep”) followed by:
5-second pause followed by:
Another chime (“♫ 1 2 3 4 5”)

The ESC is now in Programming Mode.

- 3. After one short beep (“beep”) lower throttle stick. You are now in the brake programming function.
- 4. Listen for the beeps: one beep = brake off, two beeps = brake on. If you do nothing, the ESC will simply loop through the sequence of beeps—once, then twice, then once, then twice, etc. waiting for your command to turn the brake on or off. To turn the brake *on*, advance throttle stick after the two beeps. Listen for the chime (“♫ 1 2 1 2”) indicating that the setting has been set and saved. If finished, immediately lower the throttle stick (within two seconds) to exit programming mode, then hear the number of beeps correlating to the number of cells in your battery (three for the Rapide) followed by one long beep (“beep”) indicating that the model is ready to fly.

Automatic Throttle Cutoff Protection

If the motor fails to turn within 2 seconds of throttle application, or if the temperature of the ESC reaches approximately 230F [110C], or in the event of signal loss from the receiver for a period of 1 second, the ESC will automatically cut power to the motor. Depending on the failure mode, the ESC may be “rebooted” by lowering the throttle stick, or by removing power from the ESC by disconnecting the battery.

ESC TROUBLESHOOTING GUIDE

PROBLEM	POSSIBLE REASON	SOLUTION
The motor does not turn and there is no sound after power-up.	Poor connection between battery and ESC.	Double-check the connection and battery condition and/or replace the battery connector on the battery and/or ESC.
Upon power-up, motor does not work and beeps sound: beep - beep, beep - beep, beep - beep...(each beep about 1 second in duration)	Input voltage from the battery is too high or too low.	Make sure you are using the correct battery and the battery is charged.
Upon power-up, motor does not work and long beeps sound: beep, beep, beep... (each beep about 2 seconds in duration)	The ESC is not receiving a signal from the receiver, or the signal is poor.	Make sure the receiver is receiving a signal from transmitter and make sure there are no problems with the servo lead from the ESC to the receiver. Re link the receiver to the transmitter.
Upon power-up, motor does not work and short beeps sound: beep, beep, beep... (each beep about .25 seconds in duration)	Throttle stick is not all the way down or the throttle needs to be calibrated.	Move the throttle stick all the way down, or lower the throttle end point or trim tab for the throttle channel or, calibrate the throttle as described on page 9.
Upon power-up, motor does not work and chime sounds: ♪ 1 2 3... beep beep	Throttle channel in transmitter is the wrong way (reverse/normal) and ESC has entered programming mode.	Change the direction of the throttle channel in the transmitter.
The motor turns the wrong way.	The three motor wires and ESC wires are not connected with each other properly.	“Swap” any two of the three connections between the motor and ESC with each other.

SAFETY PRECAUTIONS

Protect Your Model, Yourself & Others... Follow These Important Safety Precautions

- 1. Your Rapide should not be considered a toy, but rather a sophisticated, working model that functions very much like a full-size airplane. Because of its performance capabilities, the Rapide, if not assembled and operated correctly, could possibly cause injury to yourself or spectators and damage to property.
- 2. You must assemble the Rapide **according to the instructions**. Do not alter or modify the model, as doing so may result in an unsafe or unflyable model. In a few cases the instructions may differ slightly from the photos. In those instances the written instructions should be considered as correct.
- 3. You must use a full range R/C radio system that is in good condition. All components must be correctly installed so that the model operates correctly on the ground and in the air. You must check the operation of the model and all components before **every** flight.
- 4. If you are not an experienced pilot or have not flown this type of model before, we recommend that you get the assistance of an experienced pilot in your R/C club for your first flights. If you're not a member of a club, your local hobby shop has information about clubs in your area whose membership includes experienced pilots.
- 5. While this kit has been flight tested to exceed normal use, if the plane will be used for extremely high stress flying, such as racing, or if a motor or battery larger than the supplied stock items is used, the modeler is responsible for taking steps to reinforce the high stress points and/or substituting hardware more suitable for the increased stress.

We, as the kit manufacturer, provide you with a top quality, thoroughly tested kit and instructions, but ultimately the quality and flyability of your finished model depends on how you build it; therefore, we cannot in any way guarantee the performance of your completed model, and no representations are expressed or implied as to the performance or safety of your completed model.

Motor Safety Precautions

Failure to follow these safety precautions may result in severe injury to yourself and others.

- Wear safety glasses whenever running motors.
- Keep your face and body as well as all spectators away from the plane of rotation of the turning propeller.
- Keep loose clothing and objects such as pencils or screwdrivers that may fall out of shirt or jacket pockets away from the prop.

AMA

If you are not already a member of the AMA, please join! The AMA is the governing body of model aviation and membership provides liability insurance coverage, protects modelers' rights and interests and is required to fly at most R/C sites.

Academy of Model Aeronautics

5151 East Memorial Drive
Muncie, IN 47302-9252

Ph. (800) 435-9262
Fax (765) 741-0057



Or via the Internet at: <http://www.modelaircraft.org>

IMPORTANT!!! Two of the most important things you can do to preserve the radio controlled aircraft hobby are to avoid flying near full-scale aircraft and avoid flying near or over groups of people.

KNOW BEFORE YOU FLY

As a new owner of an unmanned aircraft system (UAS), you are responsible for the operation of this vehicle and the safety of those around you. Please contact your local authorities to find out the latest rules and regulations.

In the United States, please visit:



Federal Aviation
Administration

knowbeforeyoufly.org faa.gov/uas

REPLACEMENT PARTS

Replacement parts may be purchased from your local hobby dealer or on-line. For assistance with defective or missing parts or purchasing replacement parts contact Hobbico Product Support at the contact information on the front cover of this manual.

FLZA6660	Wing Set
FLZA6661	Fuselage
FLZA6662	Horizontal Stabilizer Set
FLZA6663	Canopy
FLZA6664	40A ESC
FLZA6665	950kV Brushless Motor

FLZA6666	Motor Mount
FLZA6667	Wing Joiner
FLZA6668	Wing Bolt M6x55
FLZA6669	Horizontal Stabilizer Joiner and Control Rod
FLZA6670	Spinner Assembly
FLZA6671	Aileron Servo
FLZA6672	13.5 X 7 Folding Propeller
FLZA6673	Flap Linkage
FLZA6674	Fuselage Servo Cover
FLZA6675	Screw Set
FLZA6676	Pushrod Set
FLZA6677	Spinner Cone
FLZA6678	Decal Set
FLZA6679	Rudder/Elevator Servo

Optional: Hook Up the Flaps

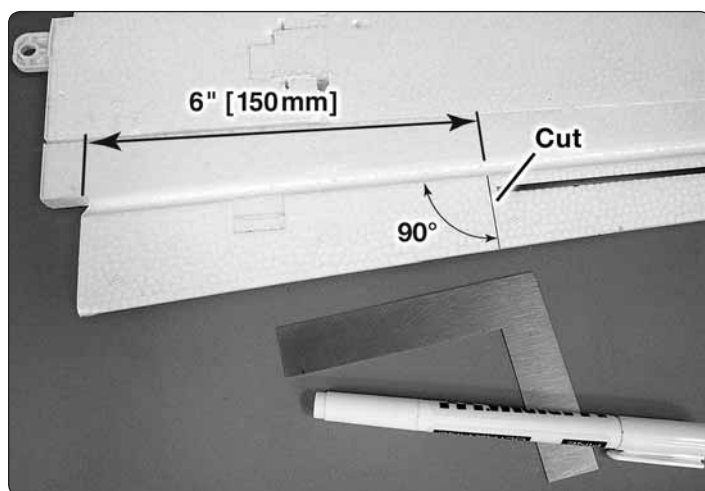

1. Mark the flap cut line near the end of the aileron spar on the **left** wing.



2. Use a hobby knife to cut through the aileron on both sides of the line making a small gap approximately 1/16" [1.5mm] wide. To complete this modification the optional flap linkage set (FLZA6673) is required (not included).

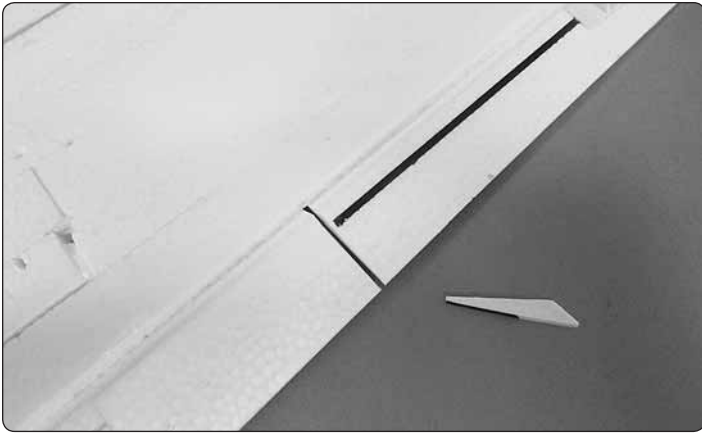

❑ 3. Remove the thin section you cut separating the flap from the aileron.

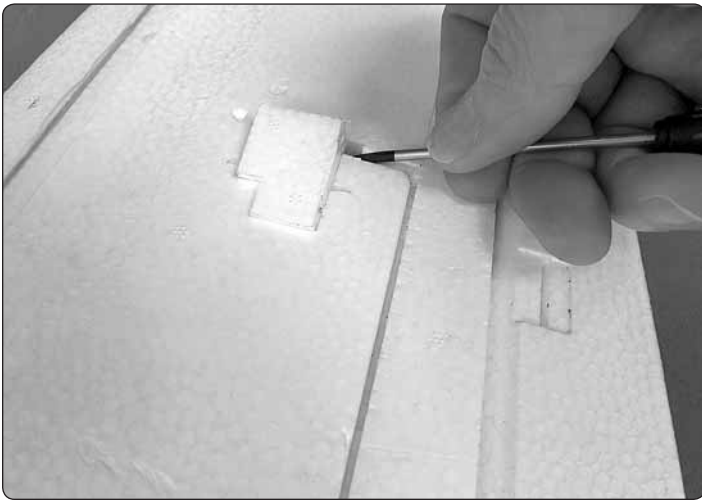

❑ 4. Extract the flap servo filler block.

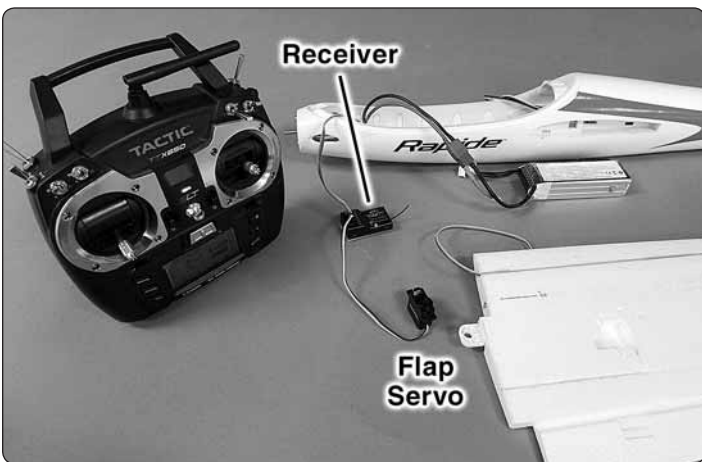

❑ 5. **Without the propeller installed**, connect one of the flap servos to the channel in your receiver that will be for the flaps. Temporarily power the flap servo with a battery through the ESC and receiver so it can be operated by your transmitter.

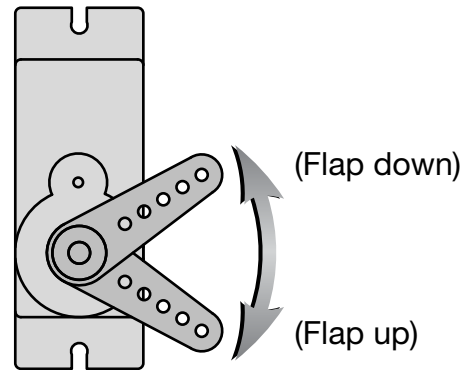
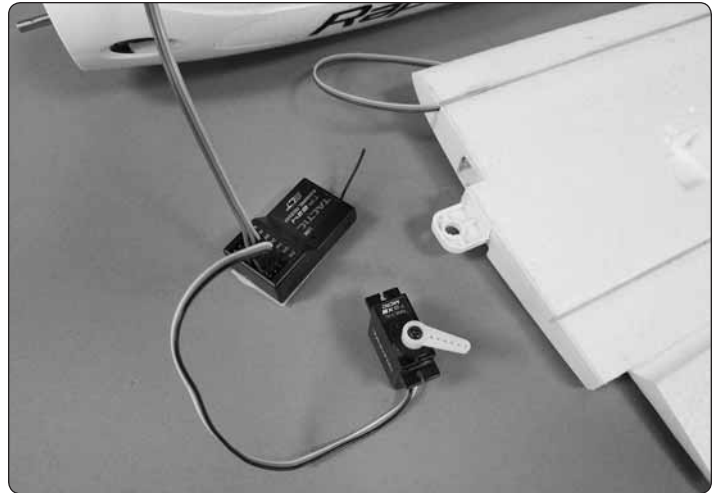

Equal throw both directions

❑ 6. Move the flap switch or dial on your transmitter to make sure the servo responds in the correct direction. If necessary, use **Servo Reversing** in your transmitter to change the servo direction. Install the servo arm on your servo so the arm will have equal travel in both directions when you move the flap switch.

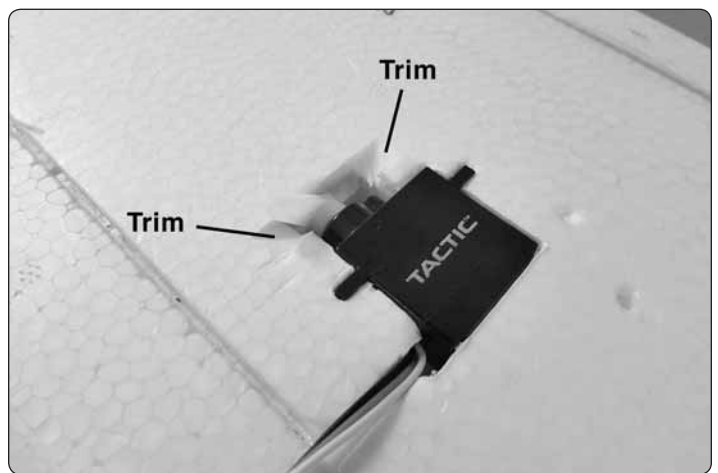

❑ 7. Test-fit the flap servo in the wing. If necessary, trim the wing around the servo arm where it interferes with full movement

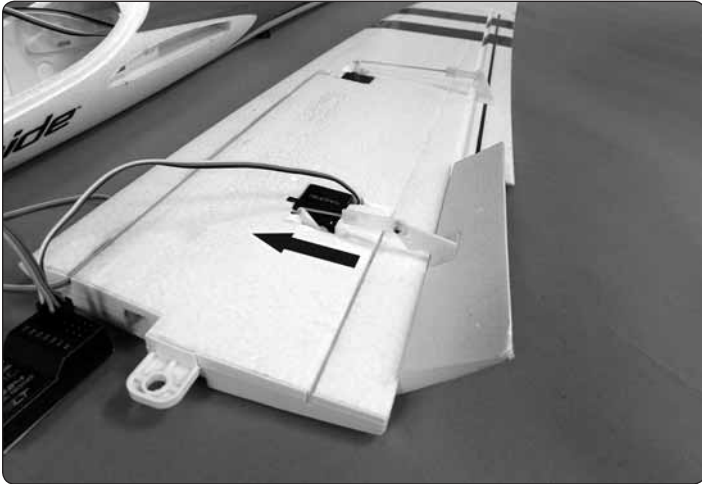
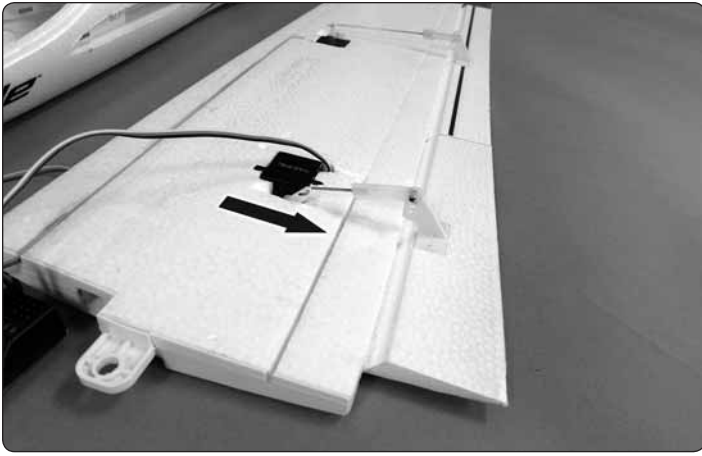

❑ 8. Use CA to glue the flap horn to the flap. Connect the pushrod to the outer hole of the servo arm and the flap horn. Operate the flaps with your transmitter. Measure and adjust the flap throw according to the **Control Throws** on page 5.

❑ 9. Glue the flap servo into place—“rubbery,” flexible glue such as canopy glue or Shoe Goo is preferred, but CA may also be used (but makes the servo more difficult to remove if ever required in the future).

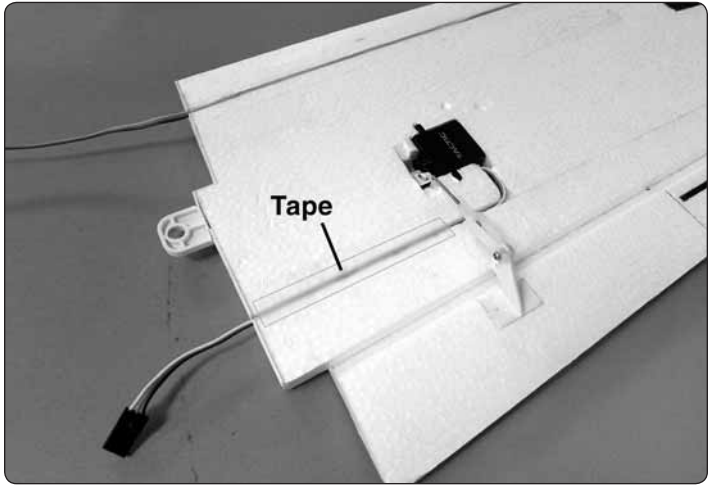

❑ 10. Guide the servo wire into the channel, then cover with clear tape.

❑ 11. Hook up the right flap the same way.

