

DC-3 AIRLINER C-47 SKYTRAIN



Wingspan: 23 in (584 mm)
Length: 17 in (432 mm)
Weight: 2.8–3.0 oz (79–85 g)
Wing Area: 66.5 in² (4.3 dm²)

RTF
READY-TO-FLY

Flyzone[®]
how high will you soar

ASSEMBLE ONLY WITH ADULT SUPERVISION *This product is suitable only for people of 14 years and older.*

Please read through this instruction booklet to **THOROUGHLY** familiarize yourself with the assembly and flight characteristics of this airplane prior to assembly. Please inspect all parts carefully before starting assembly! If any parts are missing, broken or defective, or if you have any questions about the assembly or flying of this airplane, please call us at (217) 398-8970 and we'll be glad to help.

WARRANTY Flyzone[®] guarantees this kit to be free from defects in both material and workmanship at the date of purchase. This warranty does not cover any component parts damaged by use or modification. **In no case shall Flyzone's liability exceed the original cost of the purchased kit.** Further, Hobbico, Inc. reserves the right to change or modify this warranty without notice. In that Hobbico, Inc. has no control over the final assembly or material used for final assembly, no liability shall be assumed nor accepted for any damage resulting from the use by the user of the final user-assembled product. By the act of using the user-assembled product, the user accepts all resulting liability. **If the buyer is not prepared to accept the liability associated with the use of this product, the buyer is advised to return this kit immediately in new and unused condition to the place of purchase.** To make a warranty claim contact www.flyzone.com/support



Douglas DC-3[™] airliner and Douglas C-47 Skytrain[™] – Produced under license. Boeing, Douglas DC-3, Douglas C-47 Skytrain, the distinctive Boeing logos, product markings and trade dress are trademarks of The Boeing Company. The appearance of U.S. Department of Defense (DoD) visual information does not imply or constitute DoD endorsement.



WARNING! This product includes a lithium polymer (LiPo) battery. Improper handling may result in FIRE! You are responsible for following all safety precautions as outlined in this instruction manual.

Although the DC-3/C-47 is designed to be easy to fly, it is not for the first-time pilot. We strongly recommend getting assistance from an experienced pilot for your first flights. If you're not a member of an R/C club, your local hobby shop has information about clubs in your area whose membership includes experienced pilots. You can also contact the National Academy of Model Aeronautics (AMA) which has over 2,500 chartered clubs across the country. Instructor training programs and insured newcomer training are available through any of these clubs. www.modelaircraft.org

INCLUDED ITEMS



Check the parts against those shown. If any parts are damaged or missing, please contact www.flyzone.com/support



SAFETY PRECAUTIONS

Your DC-3/C-47 should not be considered a toy, but rather a sophisticated, working model that functions very much like a full-size airplane. Because of its performance capabilities, the DC-3/C-47, if not assembled and operated correctly, could possibly cause injury to yourself or spectators and damage to property.

1. Operate the plane **according to the instructions**. **DO NOT** alter or modify the model. If you make any modifications, you void the warranty.
2. **Test** the operation of the model **before each flight** to ensure that all equipment is operating properly and that the model remains structurally sound.
3. Fly only indoors or outdoors on very calm days (with wind speeds less than 5mph) and in large open areas free of trees, people, buildings, or any other obstacles.

WARNING! A spinning propeller has the potential to cause serious and permanent injury to yourself and others.

WARNING! Keep hands clear of the propeller when handling the aircraft. Make sure the aircraft is held securely until the battery has been disconnected.

ALWAYS securely restrain the plane when the motor batteries are connected.

ALWAYS remove the motor batteries from the plane when charging.

ALWAYS switch on the transmitter first, then plug the LiPo batteries into the plane.

ALWAYS unplug the motor batteries first before switching off the transmitter.

NEVER use rechargeable (NiCd) batteries in the Tactic TTX403.

NEVER mix old and new batteries in the Tactic TTX403.

NEVER mix alkaline and standard (carbon-zinc) batteries.

NEVER touch the motor during or right after operation. The motor gets HOT!

NEVER switch off the transmitter with the motor batteries plugged in.

NEVER reach through the arc of the propeller when plugging the battery into the ESC.



LITHIUM BATTERY WARNING!

This product uses a lithium polymer (LiPo) battery. Improper handling could result in FIRE! A lithium battery fire has the potential to ignite surrounding areas and may cause property damage or cause personal injury.



For safe LiPo handling, follow all of these guidelines:

MOST IMPORTANT! Never leave the battery or charger unattended during charging or discharging.

WARNING: Read the entire instruction manual before charging your motor battery. Failure to follow the instructions could cause permanent damage to the battery and its surroundings and cause bodily harm!

ALWAYS follow the charging instructions in this manual when charging your LiPo batteries. LiPo batteries can cause serious damage or fire if misused.

ALWAYS use a LiPo-approved charger if not using the built-in charger in the Tactic TTX403 transmitter.

ALWAYS set the charger's output volts to match the battery volts if not using the built-in charger in the Tactic TTX403 transmitter.

ALWAYS charge a LiPo battery in a fireproof location away from combustible materials.

ALWAYS store and transport LiPo batteries in a fireproof container away from combustible materials.

ALWAYS KEEP OUT OF THE REACH OF CHILDREN.

ALWAYS keep LiPo batteries out of the reach of animals. A punctured battery may cause a fire.

ALWAYS disconnect the battery after the charge is complete.

ALWAYS keep a supply of sand accessible when charging a LiPo battery. Dumping sand on the battery will assist in extinguishing a LiPo chemical fire.

ALWAYS remove the battery from the plane after a crash. Set it aside in a safe location for at least 20 minutes. If the battery is damaged in the crash, it could catch fire. If the battery starts to swell, quickly move the battery to a safe location, preferably outside away from combustible material. Place it in a bucket, covering the battery with sand. Never use water to try and put out a LiPo fire.

NEVER charge or use a battery that is deformed, bent, crushed, swollen, or has any type of visible damage.

NEVER use a NiCd/NiMH charger to charge a LiPo battery.

NEVER charge in excess of 4.20V per cell.

NEVER charge at currents greater than 1C unless the battery is rated for a higher charge rate.

NEVER trickle-charge a LiPo battery.

NEVER allow the battery temperature to exceed 140 degrees F (60 degrees C).

NEVER disassemble or modify the pack wiring in any way or puncture the cells, as this may result in a fire.

NEVER discharge below 2.7V per cell.

NEVER charge the battery or set the charger on combustible materials.

NEVER charge the battery inside a vehicle or in a location that could be damaged in the event of a LiPo fire.

NEVER put a LiPo battery in the pocket of any clothing.

NEVER charge the batteries in the plane. Disconnect the batteries and remove them from the plane immediately after landing.

NEVER allow the battery to short circuit by touching exposed wires together. This may cause a fire.

NEVER operate or store batteries below 40°F or above 110°F (4-43°C)

LITHIUM POLYMER BATTERY RECYCLING

ATTENTION: The product you have purchased is powered by a rechargeable battery. At the end of the battery's useful life, under various state and local laws, it may be illegal to dispose of this battery into the municipal waste system. Check with your local solid waste officials for details in your area for recycling options or proper disposal.

WARNING: This product contains a chemical known to the State of California to cause cancer.

ASSEMBLE THE MICRO DC-3/C-47

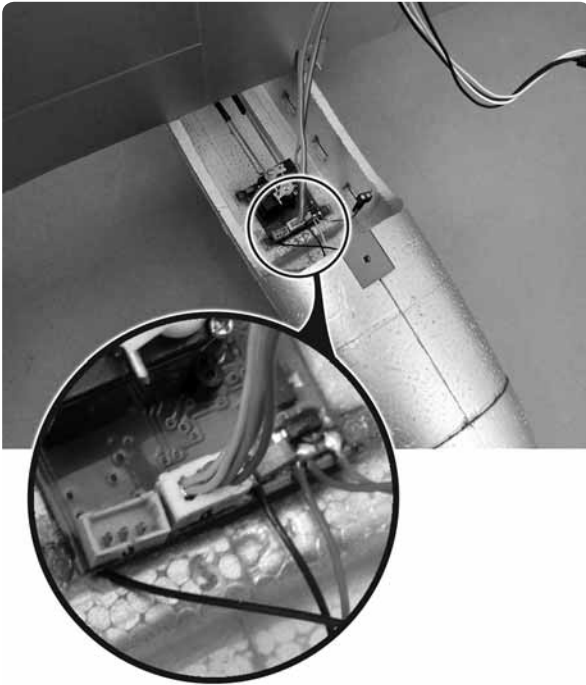

1. Plug the white micro connector from the aileron servos on the wing into the receiver board. Be careful to plug the connector in correctly.

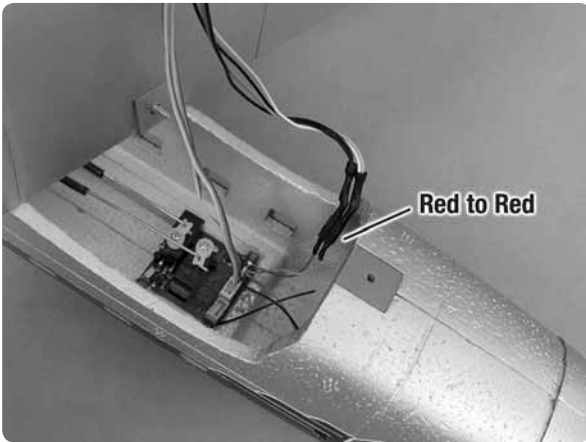

2. Connect the motor lead.

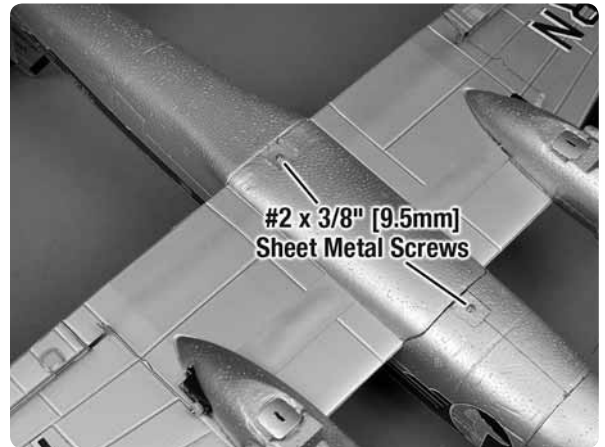
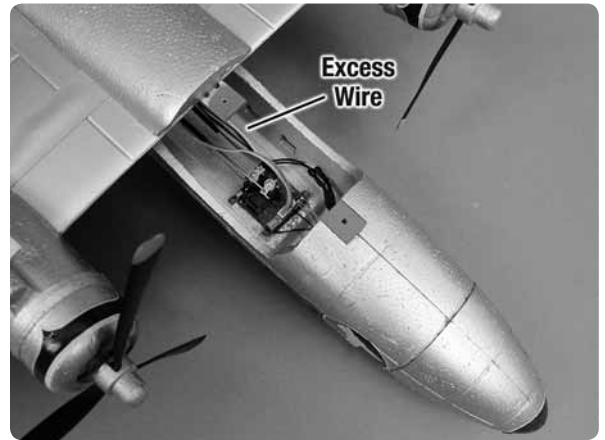

3. Attach the wing.



4. Insert the main landing gear. **NOTE:** The strut goes to the front of the slot.

PREPARE THE TTX403 TRANSMITTER

For more information on the Tactic Radio System included with the Micro DC-3/C-47 RTF visit www.tacticrc.com



Leave the TTX403 switched off.



Push and slide to remove the battery door.



Install (5) "AA" batteries.

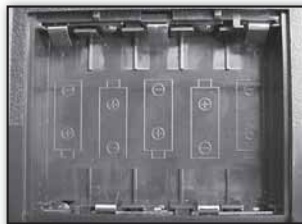

CHARGE THE 3.7V 250mAh LiPo BATTERY

Do not use the charge feature while flying the Micro DC-3/C-47!



Leave the TTX403 switched off.



Push down and slide to open the charger cover.



Flight Battery

Insert battery to charge. Make sure the battery plug is oriented properly before inserting.



Illuminated green light indicates charging. (It may be necessary to cycle the on/off switch to begin charging.) When the LED goes out, charging is complete.

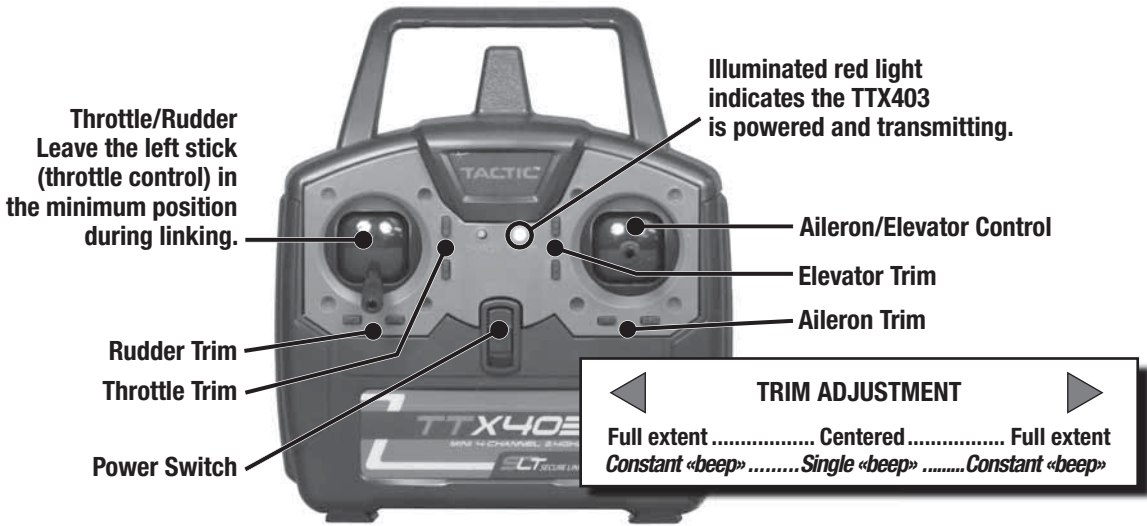

LINKING TO MICRO TX-R AIRCRAFT ■

Micro RTF aircraft includes a receiver that auto-links to a Tactic transmitter. Once the receiver is powered on, it will link automatically to a present and compatible Tactic SLT 2.4GHz signal. Please follow these steps to safely link your transmitter and aircraft the first time. Be careful of the propeller at all times. A spinning prop is dangerous and may cause personal and property damage.

1. Always power on the transmitter first.
2. Make sure the throttle stick is down and the transmitter is within 2' [600 mm] of the plane.
3. Plug in the battery to the aircraft.
4. Wait a few seconds, then move the right stick. The elevator and aileron should move. If they do not, go back to step one and try again.

HELPFUL TIP: If you are going to fly with a group, pre-link your transmitter and receiver prior to arriving at the flying location. This must be done in an environment free of Tactic SLT 2.4 GHz signals. Pre-linking ensures that familiarity is established between your transmitter and receiver. Familiarity guarantees that as long as your transmitter is powered first, your receiver will link to your transmitter regardless of the other compatible signals in the environment.

INSTALLATION AND REMOVAL OF THE LIPO BATTERY

Keep hands clear of the propellers during battery installation and removal.

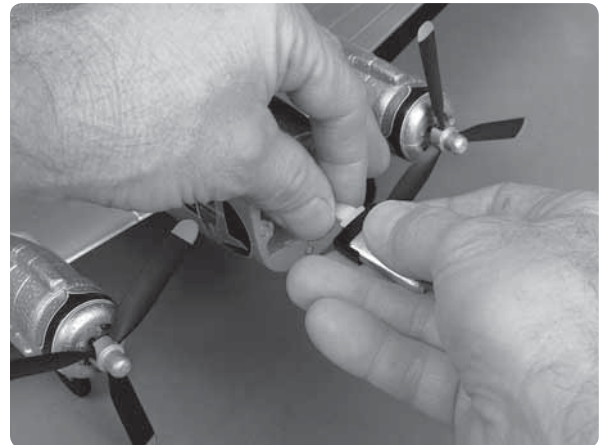

1. Power on the transmitter and move the throttle stick to 0%.
2. Remove the nose cone. Use two fingers to secure the connector during battery installation and removal.

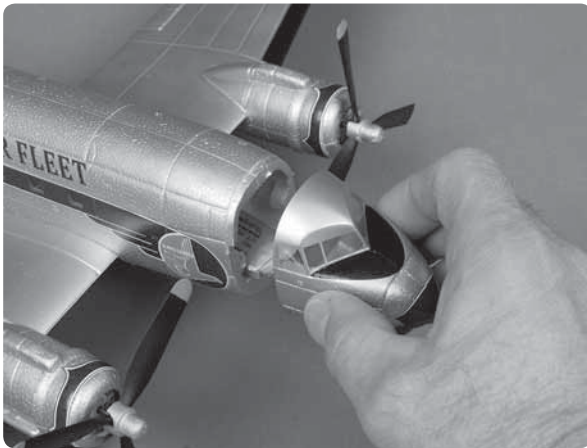

3. Press the battery into place to secure.



4. Replace the nose cone.

Disconnect and remove the battery after each flight by holding the battery lead with two fingers and removing the battery from the lead with the other hand. **Do not yank or jerk the battery from the aircraft. This could dislodge the RX board from the Micro DC-3/C-47.**

CHECK THE CONTROL SURFACE DIRECTION



Left stick moves left, rudder moves left, causing the aircraft to yaw left. Tailwheel points right.

Right stick moves left, left aileron moves up and right aileron moves down, causing the aircraft to bank to the left.

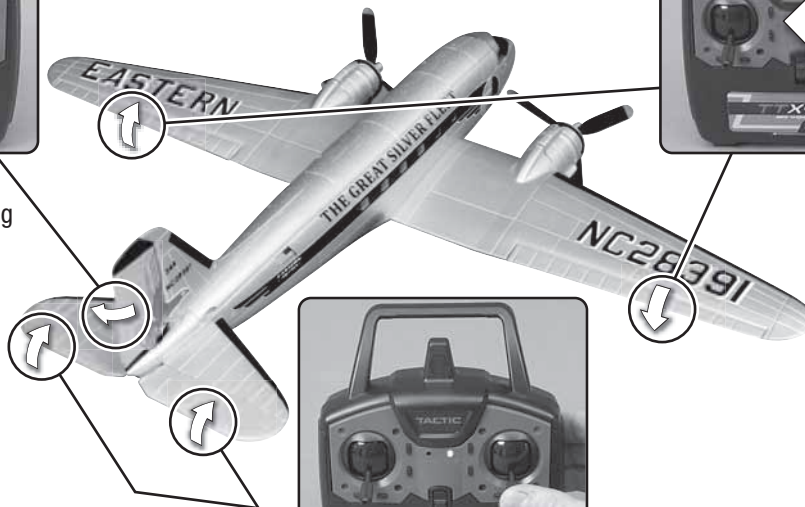

Right stick moves down, elevator moves up causing the aircraft's nose to pitch up.



CENTER THE CONTROL SURFACES ■



1. Before flight, center the aileron control surface with the aileron trim adjustment.

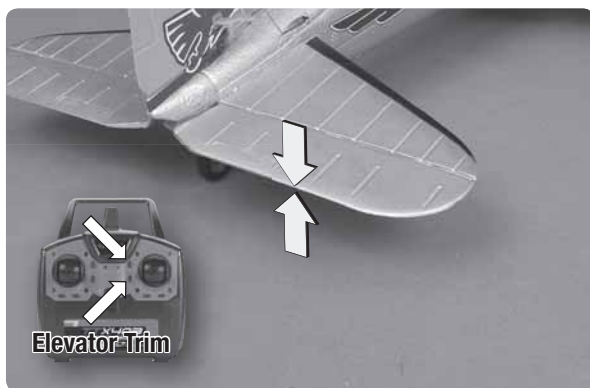

2. Before flight, center the elevator control surface with the elevator trim adjustment.

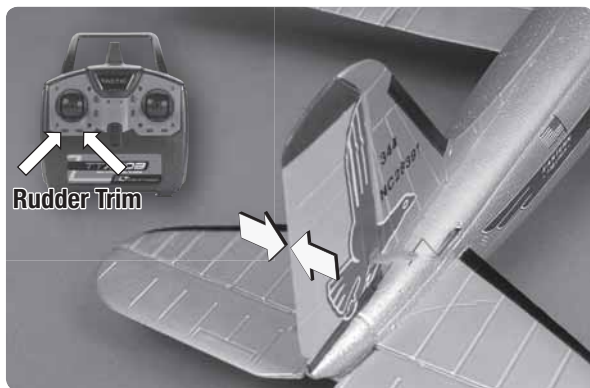

3. Before flight, center the rudder control surface with the rudder trim adjustment.

4. To alter the center position of the aileron and elevator control throws, follow these steps. Center the trim on the transmitter, then unplug the battery from the model before attempting to mechanically adjust the linkages.

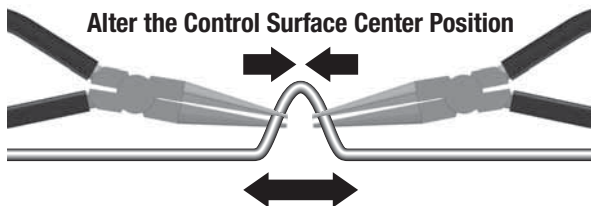

REVERSE THE CONTROL THROWS ■

If you ever need to reverse the control throws, follow this simple procedure.

Press and hold one of the corresponding control surface trim buttons and cycle the power off and then on to reverse any control surface direction. Hear a «Beep Beep Beep» sound.



CAUTION: Unplug the battery in the model before attempting to reverse the control throws.

ARM THE MOTORS ■

Keep hands and onlookers clear of propeller during arming and operation.



1. Switch on the transmitter and position the throttle control stick in the low or minimum position. Plug the battery into plane.



2. While holding the model by the tail, raise the throttle control stick to the maximum or high position. Hear a «Beep» sound.



3. Return the throttle control stick to the minimum position. Hear «Beep Beep» sound. The motors are now armed and the propellers will operate if the throttle stick is raised.

CHOOSE A FLYING FIELD

The flying field you choose is very important and should be a large, open grass field. There should not be any vehicles, buildings, power lines, trees, large rocks or anything else that your model can crash into.

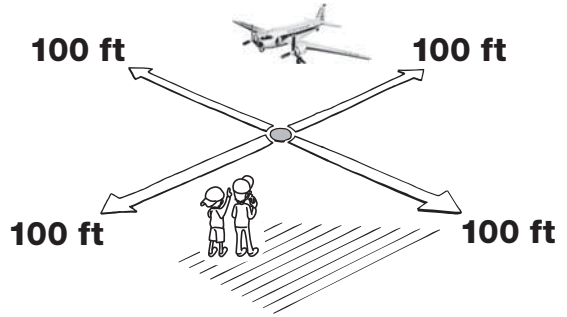

Control may be lost if the airplane is more than 500 feet [150 meters] from the transmitter.

CHOOSE A GOOD DAY TO FLY

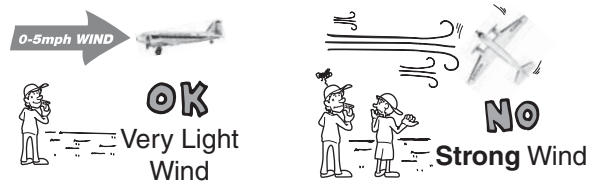

Calm weather with either no wind or wind speed of 3–5 mph [5–8 kph] is suitable for flying.

RANGE CHECK

With the transmitter powered and the battery plugged into the Micro DC-3/C-47, walk 50' [15m] from the aircraft and check the control functions for proper and smooth operation.

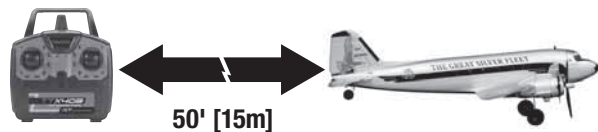

FLYING THE MICRO DC-3/C-47

If at anytime during operation, the controls or propellers become jammed or unresponsive, immediately reduce the power to the propellers and land. Fix the problem before attempting to fly.



Take off (or hand launch) heading directly into the wind.

NOTE: If you hand launch, you can remove the main landing gear by gently pulling the landing gear wires straight out of the mounts. When flying without landing gear, land on grass only to minimize damage to the motor nacelles and fuselage. **Cut power** to the motors completely just before the propellers touch the ground to prevent any damage.

WARNING: The tail wheel cannot be removed.

Hand launch with throttle set at $\frac{3}{4}$ to full power, wings level and with a slight toss (it is not necessary to aggressively throw this model to hand launch it).

Once in the air, gain altitude to allow yourself sufficient reaction time to make a correction during flight. Once you're comfortable, adjust the aileron and elevator trims one click at a time so that the Micro DC-3/C-47 flies straight and level with the control sticks centered.

Concentrate on using small aileron control inputs so the model turns without banking the wings excessively. A slight amount of up elevator may be necessary to maintain altitude going into a turn and the elevator will need to be returned to neutral when coming out of a turn to avoid gaining altitude.

It's recommended that you attempt to land before the motors lose power and don't have enough voltage to maintain altitude or the low-voltage cut-off stops the motors. Always land directly into the wind if possible. Gradually reduce power when you are close to the landing spot. When close to the ground and about to touch down, pull the elevator

stick back slightly to raise the nose of the model and slow the landing speed to "flair" for landing. Unplug the battery from the model and switch off the transmitter. Allow the motors to cool between flights.

PROPELLER REPLACEMENT

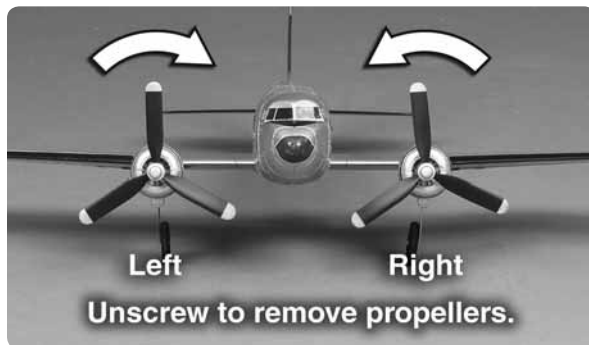

To replace the propellers, first make sure the battery is unplugged. Remove the spinner by gently wiggling it and breaking the glue joint that holds the spinner in place on the propeller.



Gently and carefully hold the motor shaft with needle nose pliers or a hemostat to keep it from rotating and gently unscrew the propellers from the shafts. As shown in the picture, the left propeller unscrews clockwise and the right propeller unscrews counterclockwise. **BE SURE you replace the propeller with the same rotating direction propeller!** The spinner can be glued back on the propeller with a small amount of aliphatic (white) glue. Allow the glue to dry sufficiently before flying the model. Gently pull on the spinner to make sure it is really glued to the propeller.

REPAIRS

Repairs can be made to the Micro DC-3/C-47 by using the following items:

- Thick Foam Safe CA (for parts adhesion), GPMR6072
- Foam safe CA accelerator, GPMR6035
- Formula 560 canopy glue, PAAR3300
- Two sets of needle nose pliers or hemostats, HCAR0625
- Hobby Knife (#11 blade), RMXR6900
- Clear tape

REPLACEMENT PARTS

To order replacement parts for the Micro DC-3/C-47, use the order numbers in the list below. Replacement parts are available only as listed. Replacement parts are not available from Product Support, but can be purchased from hobby shops or mail order/Internet order firms. If you need assistance locating a dealer to purchase parts from, contact: www.flyzone.com/support

Stock No.	Description
TACL1424	Tactic TR1424 4-Channel SLT Rx/ESC/Servo Combo
TACJ2403	Tactic TTX403 4-Channel SLT Mini Transmitter
ONXP1640	1S 3.7V 250mAh Battery
FLZA6244	1S LiPo Charger
FLZA6572	Flyzone Propeller Set Left/Right
FLZA6573	Flyzone Spinner Set Left/Right
FLZA6575	Motor Set (L&R)
FLZA6576	Aileron Servo Set
FLZA6578	Gearbox Parts Set (1 set)
FLZA6680	Fuselage Micro DC-3
FLZA6681	Wing Micro DC-3
FLZA6682	Tail Surface Set Micro DC-3
FLZA6683	Nacelle Set Micro DC-3
FLZA6684	Nose Cone Micro DC-3
FLZA6688	Fuselage Micro C-47
FLZA6689	Wing Micro C-47
FLZA6690	Tail Surface Set Micro C-47
FLZA6691	Nacelle Set Micro C-47
FLZA6692	Nose Cone Micro C-47
FLZA6694	Hardware Set
FLZA6695	Wheels Landing Gear

Optional Parts

TACJ2660	Tactic TTX660 6-Channel Computer Transmitter
----------	--

GLOSSARY

- **Center of Gravity (C.G.):** Point at which the aircraft must balance in order to fly properly.
- **Ailerons:** The flight control on the airplane that controls the ability of the airplane to bank left and right.
- **Elevator:** The flight control that controls pitch attitude. By adding power and pitching up, you can make the model climb or loop.
- **Rudder:** The flight control that controls the yaw (turning left or right).
- **Throttle:** The flight control that varies the speed of the motor/propeller.
- **Glide Slope:** The proper path for an airplane approaching a landing strip.
- **Lithium Polymer (LiPo) Battery:** Rechargeable battery which is used to power the airplane. LiPo batteries are lighter and smaller than most other types of rechargeable batteries.
- **Receiver (Rx):** The unit in the aircraft that receives the signal from the transmitter to provide the input to the servos.
- **Servo:** The device on the model that moves the flight controls.
- **Transmitter (Tx):** The hand-held unit that sends the signals to the control unit, or receiver (RX), in the aircraft.

FCC AND ETSI

FCC REQUIREMENT This device complies with part 15 of the FCC rules. Operation is subject to the following two conditions.

- (1) This device may not cause harmful interference.
- (2) This device must accept any interference received, including interference that may cause undesired operation.

NOTE: The manufacturer is not responsible for any radio or TV interference caused by unauthorized modifications to this equipment. Such modifications could void the user's authority to operate the equipment.

CE COMPLIANCE INFORMATION FOR THE EUROPEAN UNION

Instructions for Disposal of Waste Equipment by Private Users in the European Union: This symbol on the product or its packaging indicates this product must not be disposed of with other



household waste. Instead, it is the user's responsibility to dispose of their waste equipment by handing it over to a designated collection point for the recycling of waste electrical and electronic equipment. The separate collection and recycling of your waste equipment at the time of disposal will help to conserve natural resources and ensure that it is recycled in a manner that protects human health and the environment. For more information about where you can drop off your waste equipment for recycling, please contact your local city office, your household waste disposal service or location where you purchased the product.

Declaration of Conformity:

Product: Tactic TTX403 2.4GHz 4-Channel Tx/Rx

Item number: TACJ2403, Equipment class: 1



Tactic TTX403 transmitter and Tactic TR1424

receiver: The objects of the declaration described here are in conformity with the requirements of the specifications listed below, following the provisions of the European 2006/95/EC Low Voltage Directive:

EN 60950-1:2006

Safety

The objects of the declaration described here are in conformity with the requirements of the specifications listed below, following the provisions of the European R&TTE directive 1995/5/EC:

ETSI EN 300 328 V1.7.1 Technical requirements for radio equipment

ETSI EN 301 489-1 V1.8.1, 301 489-17 V1.3.2 General EMC requirements for radio equipment

Tactic

Hobbico, Inc.

2904 Research Road

Champaign, IL USA 61826

The associated regulatory agencies of the following countries recognize the noted certifications to this product as authorized for sale and use.

UK	DE	DK	BG	SE	FI	FR
EE	LV	LT	PL	CZ	SK	HU
RO	SI	AT	IT	ES	PT	IE
NL	LU	MT	CY	GR		