

P-38 Lightning

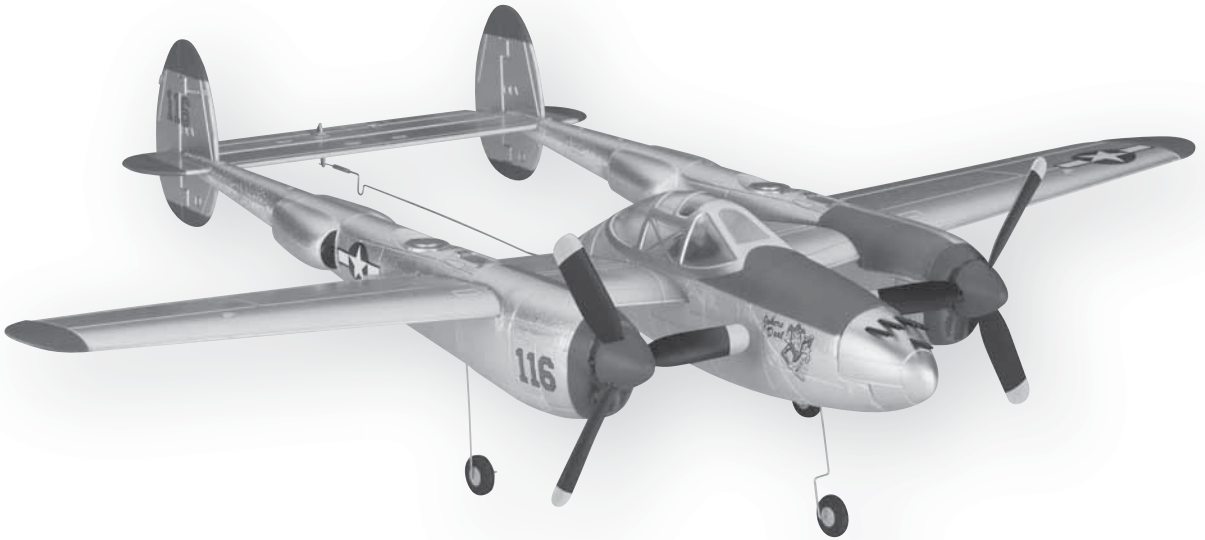

RTF
READY-TO-FLY
Tx-RTM
TRANSMITTER-READY

FlyzoneTM
how high will you soar

ASSEMBLE ONLY WITH ADULT SUPERVISION

Please read through this instruction booklet to **THOROUGHLY** familiarize yourself with the assembly and flight characteristics of this airplane prior to assembly. Please inspect all parts carefully before starting assembly! If any parts are missing, broken or defective, or if you have any questions about the assembly or flying of this airplane, please call us at (217) 398-8970 and we'll be glad to help.

This product is suitable only for people of 14 years and older.

WARRANTY

Hobbico® Inc. guarantees this kit to be free from defects in both material and workmanship at the date of purchase. This warranty does not cover any component parts damaged by use or modification. **In no case shall Hobbico's liability exceed the original cost of the purchased kit.** Further, Hobbico, Inc. reserves the right to change or modify this warranty without notice. In that Hobbico, Inc. has no control over the final assembly or material used for final assembly, no liability shall be assumed nor accepted for any damage resulting from the use by the user of the final user-assembled product. By the act of using the user-assembled product, the user accepts all resulting liability. **If the buyer is not prepared to accept the liability associated with the use of this product, the buyer is advised to return this kit immediately in new and unused condition to the place of purchase.** To make a warranty claim send the defective part or item to Hobby Services at the address below:

Hobby Services

3002 N. Apollo Dr. Suite 1
Champaign IL 61822 USA

Include a letter stating your name, return shipping address, as much contact information as possible (daytime telephone number, fax number, e-mail address), a detailed description of the problem and a photocopy of the purchase receipt. Upon receipt of the package, the problem will be evaluated as quickly as possible.

INCLUDED ITEMS

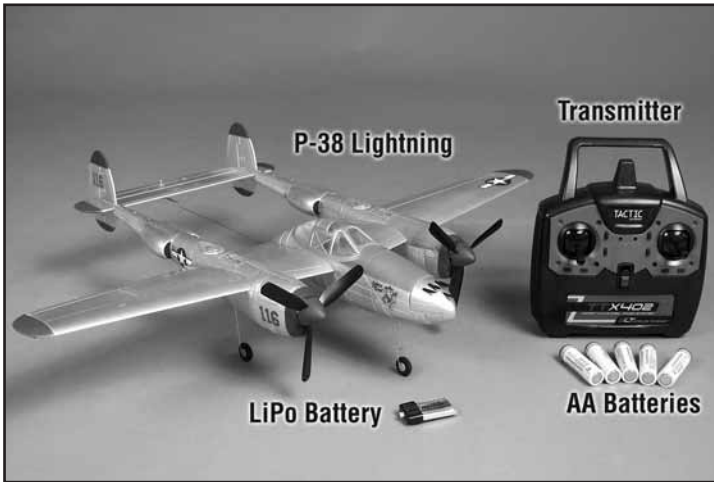

Check the parts against those shown. If any parts are damaged or missing, please call Hobby Services at: (217) 398-8970.

Note: Tx-R version (FLZA2312) does not include transmitter. It does include a 1S charger (not pictured).

FCC AND ETSI

FCC REQUIREMENT This device complies with part 15 of the FCC rules. Operation is subject to the following two conditions.



- (1) This device may not cause harmful interference.
- (2) This device must accept any interference received, including interference that may cause undesired operation.

NOTE: THE MANUFACTURER IS NOT RESPONSIBLE FOR ANY RADIO OR TV INTERFERENCE CAUSED BY UNAUTHORIZED MODIFICATIONS TO THIS EQUIPMENT. SUCH MODIFICATIONS COULD VOID THE USER'S AUTHORITY TO OPERATE THE EQUIPMENT.

CE COMPLIANCE INFORMATION FOR THE EUROPEAN UNION

Instructions for Disposal of Waste Equipment by Private Users in the European Union: This symbol on the product or its packaging indicates this product must not be disposed of with other household waste. Instead, it is the user's responsibility to dispose of their waste equipment by handing it over to a designated collection point for the recycling of waste electrical and electronic equipment. The separate collection and recycling of your waste equipment at the time of disposal will help to conserve natural resources and ensure that it is recycled in a manner that protects human health and the environment. For more information about where you can drop off your waste equipment for recycling, please contact your local city office, your household waste disposal service or location where you purchased the product.



Declaration of Conformity:

Product: Tactic TTX402 2.4GHz 4-Channel Tx Rx
Item number: TACJ2402, Equipment class: 1



Tactic TTX402 transmitter and Tactic TR421 receiver: The objects of the declaration described here are in conformity with the requirements of the specifications listed below, following the provisions of the European 2006/95/EC Low Voltage Directive:

EN 60950-1:2006 Safety

The objects of the declaration described here are in conformity with the requirements of the specifications listed below, following the provisions of the European R&TTE directive 1995/5/EC:

ETSI EN 300 328 V1.7.1 Technical requirements for radio equipment
ETSI EN 301 489-1 V1.8.1, 301 489-17 V1.3.2 General EMC requirements for radio equipment

Tactic
c/o Hobbico, Inc.
2904 Research Road
Champaign, IL USA 61826

The associated regulatory agencies of the following countries recognize the noted certifications to this product as authorized for sale and use.

UK	DE	DK	BG	SE	FI	FR
EE	LV	LT	PL	CZ	SK	HU
RO	SI	AT	IT	ES	PT	IE
NL	LU	MT	CY	GR		

PRECAUTIONS

Your Micro P-38 Lightning should not be considered a toy, but rather a sophisticated, working model that functions very much like a full-size airplane. Because of its performance capabilities, the Micro P-38 Lightning, if not assembled and operated correctly, could possibly cause injury to yourself or spectators and damage to property.

1. Operate the plane **according to the instructions**. **DO NOT** alter or modify the model. If you make any modifications, you void your warranty.
2. **Test** the operation of the model **before each flight** to ensure that all equipment is operating properly and that the model remains structurally sound.
3. Fly only indoors or outdoors on very calm days (with wind speeds less than 5mph) and in large open areas free of trees, people, buildings, or any other obstacles.
4. Although the Micro P-38 Lightning is designed to be fairly easy to fly, if you are a first-time pilot, you may still benefit from the assistance of an experienced pilot for your first flights. If you're not a member of an R/C club, your local hobby shop has information about clubs in your area whose membership includes experienced pilots. You can also contact the National Academy of Aeronautics (AMA) which has over 2,500 chartered clubs across the country. Instructor training programs and insured newcomer training are available through any of these clubs. Contact the AMA at the following address or toll-free phone number:

Academy of Model Aeronautics

5151 East Memorial Drive
Muncie, IN 47302-9252

Ph. (800) 435-9262
Fx. (765) 741-0057

www.modelaircraft.org

The R/C model hobby becomes more and more enjoyable as your experience grows. Your chances for success and graduation to higher levels are very good if you take your time and follow the flying instructions carefully and completely. We hope you enjoy flying your Micro P-38 Lightning plane.

TRANSMITTER CAUTIONS

- Do not use rechargeable (NiCd) batteries.
- Do not mix old and new batteries.
- Do not mix alkaline, standard (carbon-zinc) or rechargeable (NiCd) batteries.

BATTERY CHARGING PRECAUTIONS

1. Always remove the battery from your Micro P-38 Lightning before charging.
2. Do not leave a charging battery unattended! Unplug the battery if it gets warm, even if the charge LED has not gone out.
3. Use only the charger that comes with your Micro P-38 Lightning!

WARNING: Misuse or malfunction may overheat the battery and charger, resulting in personal injury or damage to surroundings.

LITHIUM POLYMER BATTERY RECYCLING



ATTENTION: The product you have purchased is powered by a rechargeable battery. At the end of the battery's useful life, under various state and local laws, it may be illegal to dispose of this battery into the municipal waste system. Check with your local solid waste officials for details in your area for recycling options or proper disposal.

WARNING: This product contains a chemical known to the State of California to cause cancer.

GLOSSARY

- **Ailerons:** The flight control on the airplane that controls the ability of the airplane to bank left and right.
- **Center of Gravity (C.G.):** Point at which the aircraft must balance in order to fly properly.
- **Elevator:** The flight control that controls pitch attitude. By adding power and pitching up, you can make the model climb or loop.
- **Glide Slope:** The proper path for an airplane approaching a landing strip.
- **Lithium Polymer (LiPo) Battery:** Rechargeable battery which is used to power the airplane. LiPo batteries are lighter and smaller than most other types of rechargeable batteries.
- **Receiver:** The unit in the aircraft that receives the signal from the transmitter to provide the input to the servos.
- **Servo:** The device on the model that moves the flight controls.
- **Transmitter (TX):** The hand-held unit that sends the signals to the control unit, or receiver (RX), in the aircraft.

PREPARE THE TTX402 TRANSMITTER

For more information on the Tactic Radio System included with the Micro P-38 Lightning visit www.tacticrc.com



Leave the TTX402 switched off.



Push and slide to remove the battery door.

Install (5) "AA" batteries.

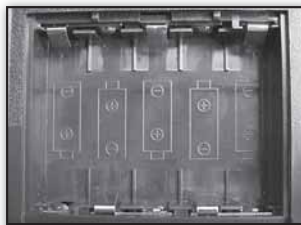

CHARGE THE 3.7V 250MAH LIPO BATTERY

Do not use the charge feature while flying the Micro P-38 Lightning!



Leave the TTX402 unpowered.



Push down and slide to open the charger cover.



Insert battery to charge. Make sure the battery plug is oriented properly before inserting.



Illuminated green light indicates charging. (It may be necessary to cycle the on/off switch to begin charging.) When the LED goes out, charging is complete.

TX-R ONLY: CHARGE THE 3.7V 250MAH LIPO BATTERY

1. Install the (5) AA batteries in the included 1S charger using the polarity diagram shown in the battery compartment.
2. Plug the 3.7V battery in to the charger as shown. The illuminated LED indicates charging.

Warning: Do not connect the battery other than in the orientation shown!

3. When the LED goes out, charging is complete.



TTX402 FUNCTIONS

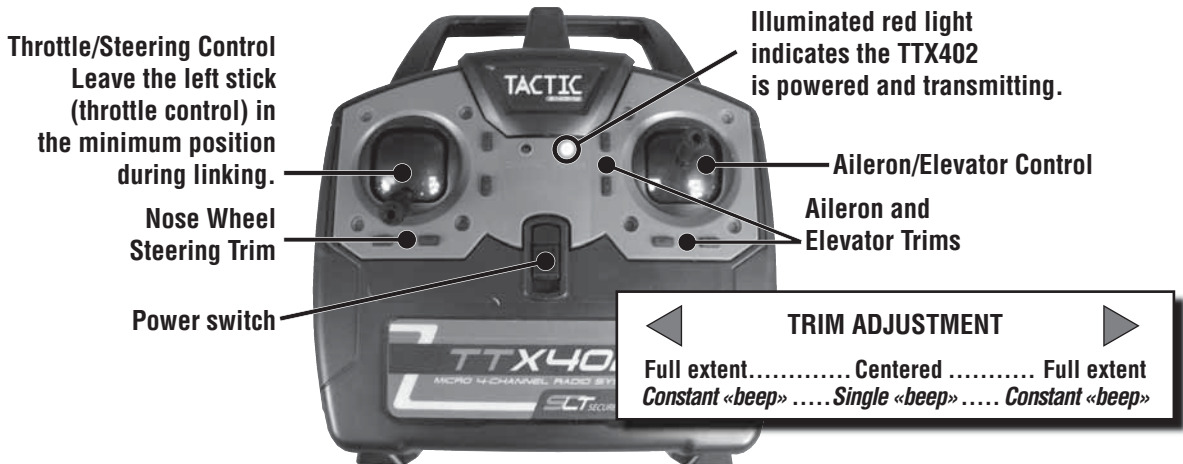

TX-R ONLY: POWER ANYLINK OR A TACTIC 2.4GHZ TRANSMITTER

AnyLink must be in Normal Mapping (1 Beep) when Futaba®, Hitec® or Tower Hobbies transmitters are used with Tx-R aircraft. If using a Spektrum® or JR® transmitter, AnyLink must be in Alternate Mapping (2 Beeps). To change the mapping, consult your AnyLink instruction manual.

All trademarks are property of their respective owners.

LINKING TO MICRO TX-R AIRCRAFT

Micro Tx-R aircraft include a receiver that auto-links to a Tactic transmitter. Once the receiver is powered, it will link automatically to a present and compatible Tactic SLT 2.4GHz signal. Please follow these steps to safely link your transmitter and aircraft the first time.

1. Always power the transmitter or AnyLink first.
2. Make sure the throttle stick is down.
3. Plug in the battery to the aircraft.

HELPFUL TIP: If you are going to fly with a group, pre-link your transmitter and receiver prior to arriving at the flying location. This must be done in an environment free of Tactic SLT 2.4GHz signals. Pre-linking ensures that familiarity is established between your transmitter and receiver. Familiarity guarantees that as long as your transmitter is powered first, your receiver will link to your transmitter regardless of the other compatible signals in the environment.

INSTALLATION AND REMOVAL OF THE LIPO BATTERY

Keep hands clear of the propellers during battery installation and removal.



Remove nose cone. Use two fingers to secure connector during battery installation and removal.

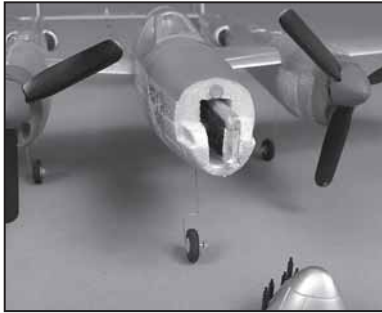

Press battery into place to secure.



Replace nose cone.

Disconnect and remove the battery after each flight by holding the battery lead with two fingers and removing the battery from the lead with the other hand. **Do not yank or jerk the battery from the aircraft. This could dislodge the RX board from the Micro P-38 Lightning.**

CHECK THE CONTROL SURFACE DIRECTION

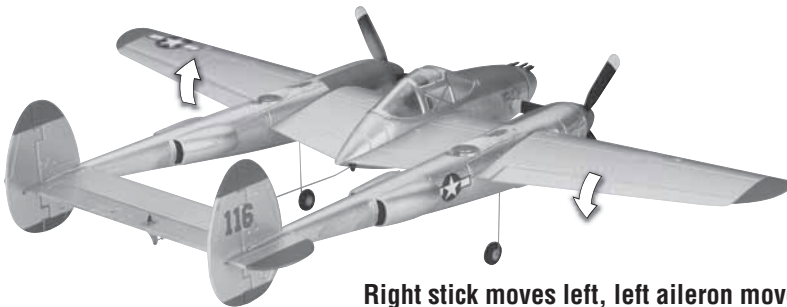

Right stick moves left, left aileron moves up and right aileron moves down, causing the aircraft to bank to the left.

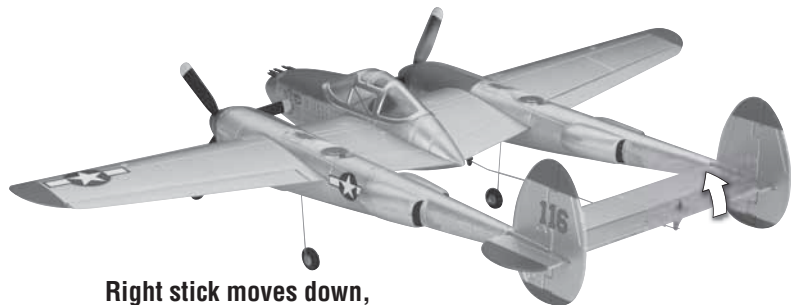

Right stick moves down, elevator moves up causing the aircraft's nose to pitch up.

CENTER THE CONTROL SURFACES

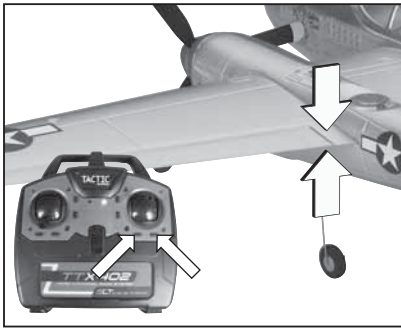

Before flight, center aileron control surface with aileron trim adjustment.

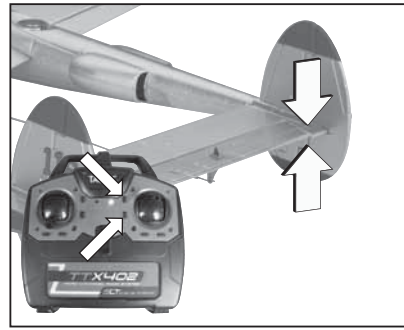

Before flight, center elevator control surface with elevator trim adjustment.

REVERSE THE CONTROL THROWS

If you ever need to reverse the control throws, follow this simple procedure.



CAUTION: *Unplug the battery in the model before attempting to reverse the control throws.*

Press and hold one of the corresponding control surface trim buttons and cycle the power off and then on to reverse any control surface direction.

ARM THE PROPELLERS

Keep hands and onlookers clear of propeller during arming and operation.

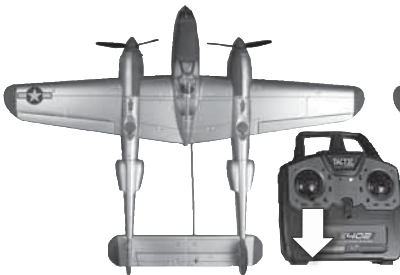

Throttle control stick is in the low or minimum position. Plug battery into plane.

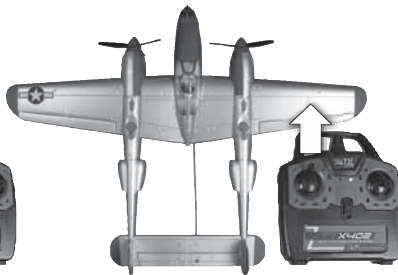

Raise the throttle control stick to the maximum or high position. Hear a «Beep» sound.

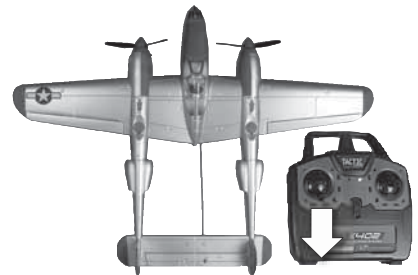

Return the throttle control stick to the minimum position. Hear «Beep Beep» sound. The motors are now armed and the propellers will operate if the throttle stick is raised.

ADJUSTMENT OF ELEVATOR LINKAGE:

To alter the center position, or increase/decrease the elevator control throw, follow these steps. Be sure to unplug the battery from the model before attempting to mechanically adjust the linkage.

ALTER THE CENTER POSITION

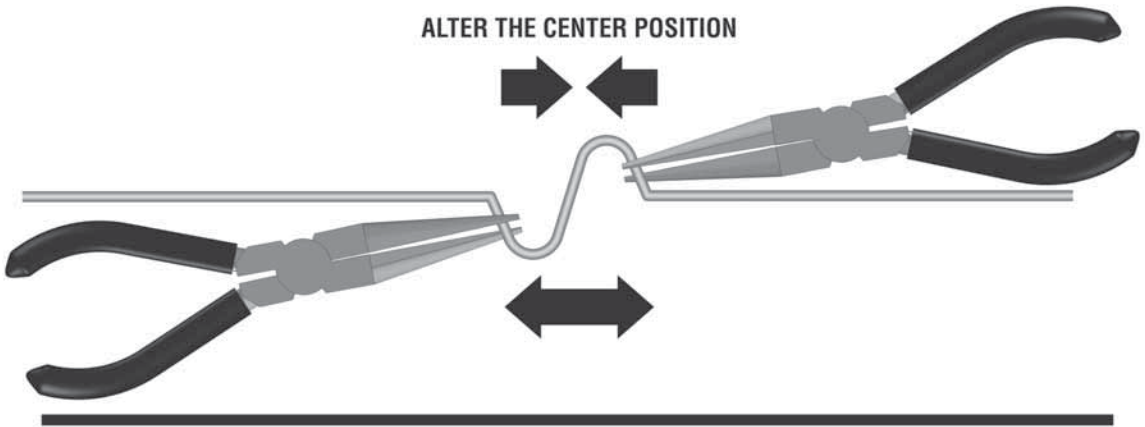

INCREASE/DECREASE THROWS

Moving the pushrod outward decreases the control throw

Moving the pushrod inward increases the control throw

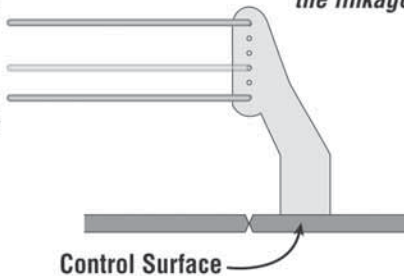

Use caution when removing and reinstalling the pushrod in the control horn to avoid accidentally disconnecting the linkage from the Rx board.

CHOOSE A FLYING SITE

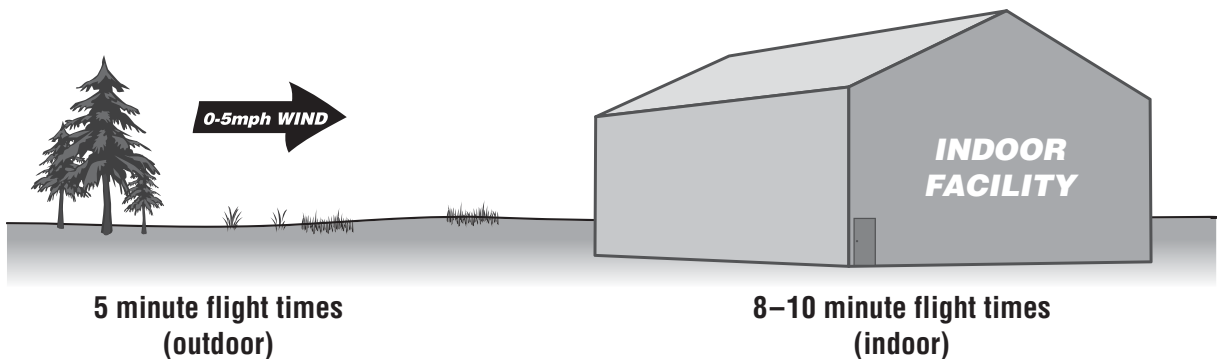

RANGE CHECK

With the transmitter powered and the battery plugged into the Micro P-38 Lightning, walk 50' [15m] from the aircraft and check the control functions for proper and smooth operation.



FLYING THE MICRO P-38 LIGHTNING

If at anytime during operation, the controls or propellers become jammed or unresponsive, reduce the power to the propellers and land. Fix the problem before attempting to fly.

Take off (or hand launch) heading directly into the wind.

NOTE: If you hand launch, you can remove the landing gear by gently pulling the landing gear wires straight out of the mounts. It is highly recommended to cut power to the motors completely just before the propellers touch the ground to prevent any damage.

Hand launch with throttle set at $\frac{3}{4}$ to full power, wings level and with a slight toss (it is not necessary to aggressively throw this model to hand launch it).



Once in the air, gain altitude to allow yourself sufficient reaction time to make a correction during flight. Once you're comfortable, adjust the aileron and elevator trims one click at a time so that the Micro P-38 Lightning flies straight and level with the control sticks centered.

Concentrate on using small aileron control inputs so the model turns without banking the wings excessively. A slight amount of up elevator may be necessary to maintain altitude going into a turn and the elevator will need to be returned to neutral when coming out of a turn to avoid gaining altitude.

It's recommended that you attempt to land before the motors lose power and don't have enough voltage to maintain altitude. Always land directly into the wind if possible. Gradually reduce power when you are close to the landing spot and when close to the ground and about to touch down, pull the elevator stick back slightly to raise the nose of the model and slow the landing speed to "flair" for landing. Unplug the battery from the model and switch off the transmitter. Allow the motors to cool between flights.

PROPELLER REPLACEMENT

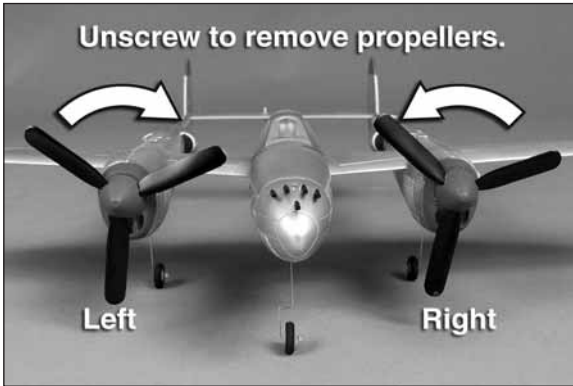

To replace the propellers, first make sure the battery is unplugged. Remove the spinner by gently wiggling it and breaking the glue joint that holds the spinner in place on the propeller. Gently and carefully hold the motor shaft with needle nose pliers or a hemostat to keep it from rotating and gently unscrew the propellers from the shafts. As shown in the picture, the left propeller unscrews clockwise and the right propeller unscrews counterclockwise. **BE SURE you replace the propeller with the same rotating direction propeller!** The spinner can be glued back on the propeller with a small amount of aliphatic (white) glue. Allow the glue to dry sufficiently before flying the model. Gently pull on the spinner to make sure it is really glued to the propeller.

REPAIRS

Repairs can be made to the Micro P-38 Lightning by using the following items:

- Thick Foam Safe CA (for parts adhesion), GPMR6072
- Foam safe CA accelerator, GPMR6035
- Two sets of needle nose pliers or hemostats, HCAR0625
- Hobby Knife (#11 blade), RMXR6900
- Clear tape

REPLACEMENT PARTS

To order replacement parts for the Micro P-38 Lightning, use the order numbers in the list below. Replacement parts are available only as listed. Replacement parts are not available from Product Support, but can be purchased from hobby shops or mail order/Internet order firms. If you need assistance locating a dealer to purchase parts from, contact:

Product Support

Phone: 217-398-0007

Fax: 217-398-7721

E-mail: productsupport@hobbico.com

Stock No.	Description
FLZA6500	Wing
FLZA6501	Pod/Boom Set
FLZA6502	Tail Surfaces Set
FLZA6503	Spinners (2)
FLZA6504	Landing Gear Set
FLZA6505	Canopy
FLZA6506	Pilot
FLZA6507	Battery Hatch
FLZA6508	Hardware Set

Stock No.	Description
FLZA6509	Decals
FLZA6510	Gearbox
FLZA6511	Motor Set w/Pinions
FLZA6512	Propeller (2 pcs.)
FLZA6513	Aileron Servo Set
GPMP0770	1S 3.7V 250mAh 20C LiPo
TACJ2402	TTX402 2.4GHz Transmitter
TACL1424	Micro Receiver w/Servos



Flyzone™
how high will you soar™