

FUJI **ENGINES**™

Instructions for the Fuji Electric Starter BT-50

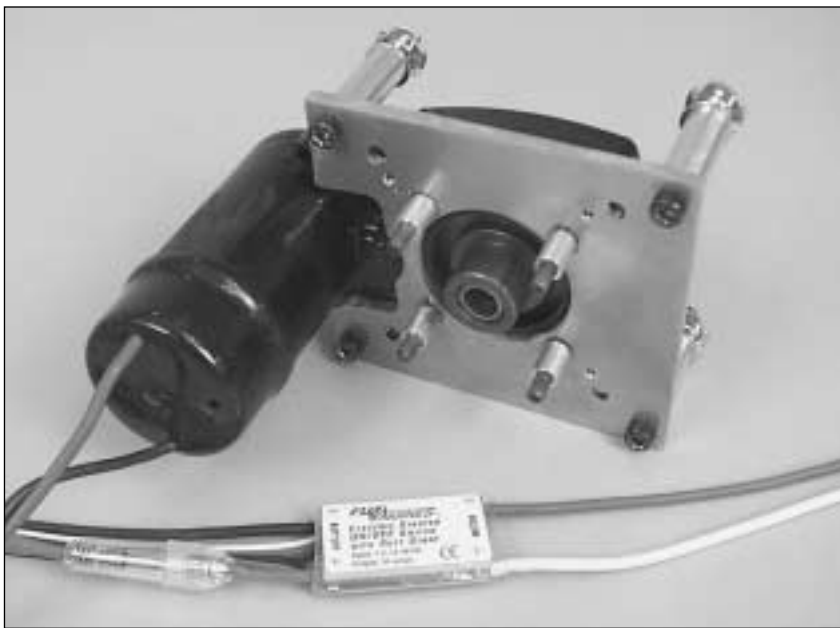

**Manufactured by FUJI IMVAC INC.
YOKOHAMA, 235-0005 JAPAN
Worldwide Distributor (except Japan): Hobbico® , Inc.
Champaign, IL 61826 USA
www.fujiengines.com**

INTRODUCTION

These instructions explain the installation of the Electric Starter BT-50 on the Fuji BT50SA engine.

FUJI BT-50 ELECTRIC STARTER PARTS LIST

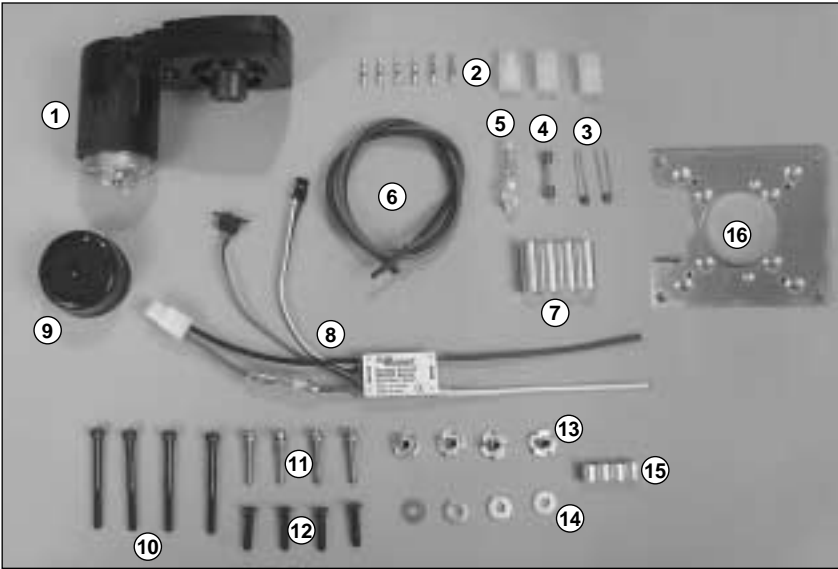

- | | |
|---|--|
| <p>1. Electric starter case with motor</p> <p>2. Tamiya connectors</p> <p>3. Capacitors</p> <p>4. 30A fuse</p> <p>5. Fuse holder</p> <p>6. Electrical wire</p> <p>7. Aluminum firewall spacers</p> <p>8. Electronic soft start module</p> <p>9. Rubber cap</p> | <p>10. Firewall mounting socket head cap screws</p> <p>11. Engine mounting bolts</p> <p>12. Electric starter mounting bolts</p> <p>13. Firewall blind nuts</p> <p>14. Firewall washers</p> <p>15. Engine mounting spacers</p> <p>16. Aluminum Electric starter mounting plate</p> |
|---|--|

PARTS AND TOOLS REQUIRED FOR THE INSTALLATION THE BT-50 ELECTRIC STARTER

- | | |
|---|--|
| <ul style="list-style-type: none"> ▪ 6 to 10 cell, 1900mAh battery (GPMP0740), (GPMP0741), (GPMP0742), (GPMP0743) ▪ Flexible pushrod (GPMQ3700) ▪ 30-min epoxy (GPMR6043) ▪ Thin CA (GPMR6001) ▪ Electric noise suppressant (see note below) | <ul style="list-style-type: none"> ▪ Phillips screwdriver (HCAR1090) ▪ Solder iron and soldering supplies (HCAR0776) ▪ Electric drill with 1/4" [6.4mm] drill bit ▪ Great Planes® Pro™ Thread Locking Compound (GPMR6060) ▪ Metric allen wrenches (HCAR0521) ▪ Electrical tape |
|---|--|

REPLACEMENT PARTS

To order replacement parts for the Fuji BT-50, use the following order numbers. Replacement parts are available only as listed. Replacement parts are not available from Product Support, but can be purchased from hobby shops or mail order/Internet order firms. If you need assistance locating a dealer to purchase parts, visit www.greatplanes.com and click on "Where to Buy." If this electric starter is missing parts, contact Product Support (see back cover).

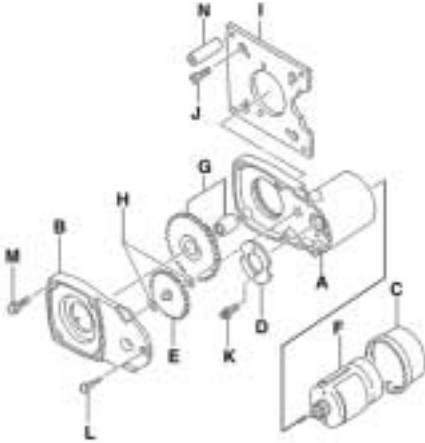

(A)	FJIG1201	Starter Gear Case A
(B)	FJIG1202	Starter Gear Case B
(C)	FJIG1203	Starter Motor Cover
(D)	FJIG1204	Starter Motor Spacer
(E)	FJIG1205	Starter Gear 2.3 to 1
(F)	FJIG1206	Starter Motor
(G)	FJIG1207	Starter Gear Assembly
(H)	FJIG1208	0.5 Gear Shift Collar
(I)	FJIG4720	Starter Mounting Plate
(J)	FJIG7171	5x15 Beveled Head Phillips Screws
(K)	FJIG7172	4x10 Set Screw
(L)	FJIG7173	4.5x12 Beveled Screw
(M)	FJIG7174	4x30 Phillips Head Screw With Washers
(N)	FJIG3650	Starter Collar A

IMPORTANT NOTES

1. The electric starter depicted in this manual has a Battery Eliminator Circuit (BEC). The BEC circuit is rated at 1 Amp. **Do not use this circuit to power the receiver of your airplane.** The BEC cannot handle more than three regular sized servos. If you do so the BEC will fail with possible catastrophic consequences for your airplane. **Turn off** the micro switch on the electronic soft start module to disconnect the BEC circuit.

2. In order to avoid interference from the gas engine, you must use an electric noise suppressant on the electric starter's wiring that comes back from the electric motor. Radio Shack® offers two types of electrical noise suppressants. The simplest noise suppressant is called "Snap Together Ferrite Choke" and its part number is 273-105. The other type Radio Shack offers is the "10 Amp Noise Filter". Its part number is 27-051.

3. The starter's remote On/Off switch should always be assigned to a **spring-loaded switch** on your transmitter. It is important that you do this for safety reasons. The spring loaded switch will always be in the "Off" position when the transmitter is turned on and the starter motor will always stop spinning when you release the switch after the engine is started.

4. Always include a “kill switch” in your gas engine installation. A Great Planes Ignition Switch Harness (GPMG2150) is recommended.
5. It is strongly recommended that you use a PCM receiver to control your airplane. PCM receivers can handle vibrations and the type of electronic interference a gas engine produces much better than FM receivers can.
6. The minimum firewall size recommended for the Fuji BT-50 electric starter installation is 1/4" [6.4mm] birch ply. Lite ply firewalls need to be twice as thick as birch ply firewalls and larger washers (such as fender washers) than the washers provided in the kit should be used.

INSTALLATION OF THE BT-50 ELECTRIC STARTER ON THE BT-50SA

Preparations

The Fuji BT-50 electric starter requires a minimum battery size of 6-cell, 1900 mAh. This minimum battery size will start a properly set-up Fuji BT-50SA at least 30 times on a full charge without any problems. For longer starting performance, you can use a 7-cell, 8-cell or 10-cell battery.

Electrical Installation

1. Locate the electric starter motor and the two 14-gauge black and red wires. Solder the wires to the motor, making sure that the red wire is connected to the motor tab with the red dot.



2. Locate the two motor capacitors. Lightly sand a spot on the side wall of the motor. Solder the capacitors as shown above. Each capacitor should have one leg soldered to one motor tab and the other to the motor side wall. Locate the motor's rubber cap. Insert the motor wires through the holes in the cap and slip the cap over the motor to protect it from dirt. Apply a couple of drops of thin CA to the cap to tack glue it to the electric starter's case or tape it in place.

3. Install a noise suppressant on the electric motor wiring, preferably some place on the wire where you can secure the suppressant to the fuselage. If you are using a Snap Together Ferrite Choke type of noise suppressant, install it as shown above. If you are using some other type of noise suppressant, follow the manufacturer's instructions to install it.

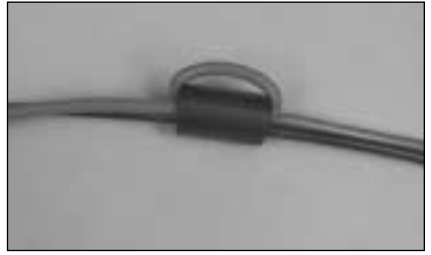

4. Find one of the female Tamiya connectors and its pins. Solder the pins to the ends of the wires and install the connector to the pins. Make sure the connector and its polarity is the same as that on the battery connector already installed on the On/Off soft start switch.

5. Find one male Tamiya connector and its pins. Solder the pins to the end of the motor wires on the On/Off soft start switch. This connector will plug into the one installed in the previous step. Make sure that the pins are installed into the connector such that the white wire from the On/Off soft start switch goes with the red wire from the starter motor and that the blue wire from the On/Off soft start switch goes with the black wire from the starter motor.

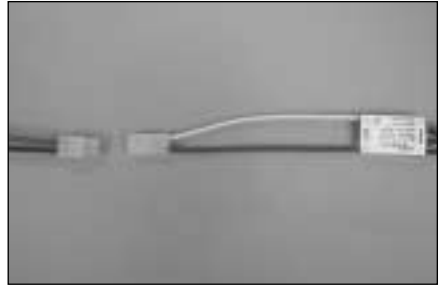

6. The left over male Tamiya connector is for you to install on the battery you will use to power the electric starter system. Make sure the polarity on your battery matches the polarity of the electric starter system.

Installing the Electric Starter on the Engine

1. Remove the engine mounting plate from the engine.



2. Locate the electric starter mounting plate, four beveled socket head screws and four short (9mm x 10mm) spacers. Install the plate onto the engine with the spacers between the engine and the mounting plate. The

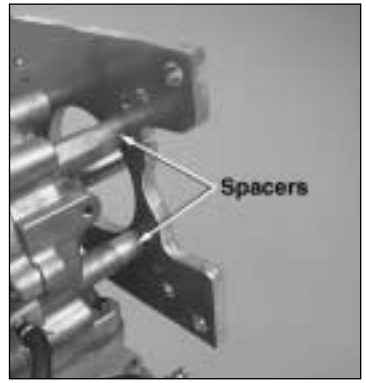
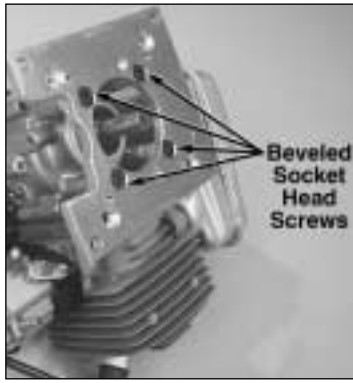

cut-out in the plate must be facing the carburetor's side of the engine. **Note:** It is important that you use thread locking compound on the engine mounting screws.

3. Locate the electric starter assembly and four 4mm x 32mm Phillips head bolts with washers. Install the electric starter onto the electric starter mounting plate as shown above using the four bolts. Use thread locking compound on these bolts.

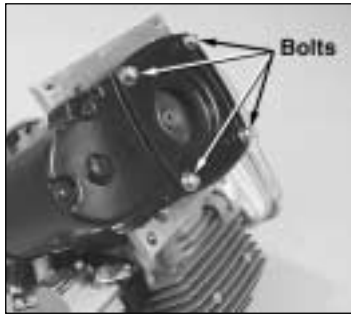

Installing the Engine to the Airplane

1. Locate the electric starter template and center it on your firewall. Use tape to hold it in place. Drill the 1/4" [6.4mm] mounting holes at the places indicated by the template.



2. Use one of the supplied bolts, a washer and a spacer to install the supplied blind nuts in the back of the firewall as shown above. Use a small dab of epoxy on the blind nuts to make sure they stay on when you take the mounting bolts off.

3. Install the engine in place using the spacers, bolts and washers supplied. Make sure the engine is centered in the firewall and that the mounting bolts are tight. Use thread locking compound on the engine mounting bolts.

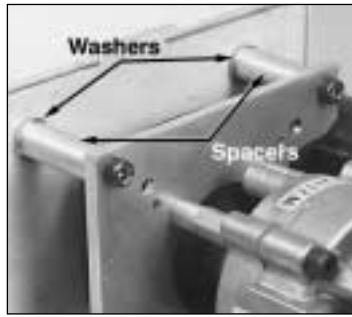

4. Route the starter's wiring to the inside of your airplane. Connect the soft start module to the electric starter and to the receiver. Also, connect it to the starter's battery.
5. Use a flexible control rod to connect the carburetor's arm to the throttle servo.
6. Securely install your starter battery inside your airplane. Make sure you have full access to the battery.
7. The electric starter is now installed on your airplane

PROCEDURE TO START A GAS ENGINE WITH THE FUJI ELECTRIC STARTERS

1. Fuel your airplane.
2. Turn your transmitter and receiver on.
3. Connect the starter's battery to the soft start module.
4. Make sure that nothing is in the way of the propeller. Stay clear from the propeller.
5. Turn the kill switch to the "Off" position.
6. Choke the engine's carburetor.
7. Set the carburetor to full throttle.
8. Flip the starter's switch on for 4 to 5 seconds to prime the engine.
9. Set the carburetor slightly above idle.
10. Turn the kill switch to the "On" position.
11. Again, clear the prop. Make sure that nothing can be "sucked in" the propeller when the engine starts.
12. Flip the starter's switch on for 4 to 5 seconds.

If the engine does not start, wait for 10 seconds and then repeat step 12 five to six times. If the engine still does not start, repeat steps 5 to 12.

After your flight is completed, make sure you disconnect the starter's battery before you turn off your transmitter and receiver.

If you have any questions, or this electric starter is missing parts, contact Great Planes Product Support:

Great Planes Product Support
1610 Interstate Drive Champaign, IL 61822
(217) 398-8970, Ext 2
productsupport@greatplanes.com

**90-Day Limited Warranty
For USA and Canada**

Fuji Engines warrants this product to be free from defects in materials and workmanship for a period of 90 days from the date of purchase. During that period, Fuji Engines will, at its option repair or replace without service charge any product deemed defective due to those causes. You will be required to provide proof of purchase date (receipt or invoice).

This warranty does not cover damage caused by crash, abuse, misuse, alteration or accident. Damage caused by customer disassembly, tampering, use of substandard fuel, use of incorrect accessories or any use of the starter for which it is not specifically intended will automatically void the warranty of the starter. If there is damage resulting from these causes within the stated warranty period, Fuji Engines will, at its option, repair or replace it for a service charge not greater than 50% of the current retail list price. Be sure to include your daytime telephone number and e-mail address in case we need to contact you about your repair.

Under no circumstances will the purchaser be entitled to consequential or incidental damages. This warranty gives you specific legal rights, and you may also have other rights, which vary from state to state.

If you attempt to disassemble or repair this unit yourself, it may void the warranty.

For service on your Fuji Engines product, either in or out of warranty, send it post paid and insured to:

Hobby Services
1610 Interstate Drive
Champaign, IL 61822 U.S.A.
(217) 398-0007
www.hobbyservices.com

Along with your starter and proof of purchase date, please include a complete written explanation detailing the problem(s). State your name and address clearly. For repairs not covered under warranty, you must specify whether you wish the charges to be billed COD or if you wish to be notified of the charges so you can send a check.

Outside USA and Canada, contact
local importer for warranty information.