

FUJI-IMVAC™

Operator's Manual for BF-25EI and BF-34EI EIS 4-Stroke Engines

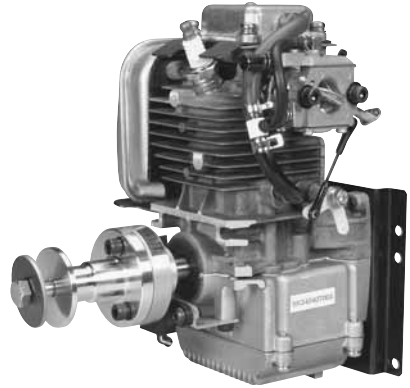
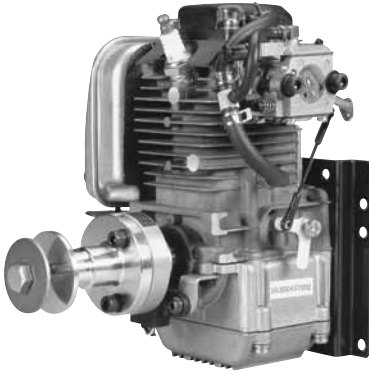

BF-25EI Specifications

Displacement:	24.5cc
Weight:	2.1 kg [4.7 lb]
Bore/Stroke:	24 x 24mm
Peak Horsepower:	1.6hp @ 7,500 rpm
Peak Torque:	.14kgfm @ 5,000 rpm
RPM:	1,400 – 9,000 rpm
Fuel:	Automotive Unleaded Gasoline
Ignition Battery:	4.8V, 850mAh NiMH (battery pack provides 3.5 hrs. operation)

BF-34EI Specifications

Displacement:	34cc
Weight:	2.6 kg [5.9 lb]
Bore/Stroke:	39 x 28mm
Peak Horsepower:	2.0hp @ 7,500 rpm
Peak Torque:	.20kgfm @ 5,000 rpm
RPM:	1,400 – 7,500 rpm
Fuel:	Automotive Unleaded Gasoline
Ignition Battery:	4.8V, 850mAh NiMH (battery pack provides 3.5 hrs. operation)

Manufactured by FUJI-IMVAC, Inc.
YOKOHAMA, 235-0005 JAPAN
Worldwide Distributor (except Japan): Hobbico, Inc.
Champaign, IL 61826 USA
www.fuji-imvac.com

Fuji-Imvac is not related to the original Fuji Engines sold by Mecoa.

SAFETY TIPS AND WARNINGS

- Always use a balanced spinner and a balanced propeller. An unbalanced spinner and propeller combination will cause high levels of vibration and may cause damage to the engine and airframe.
- Always use a lightweight spinner on your engine. Lightweight spinners are considered to be those with a cone wall of 1mm or less. Heavy spinners could cause the propeller shaft to break.
- Securely tighten the spinner and propeller on the engine to prevent them from being thrown off of the engine while it's running.
- Never use a propeller that has hit the ground. Even though it may look good to a visual inspection, it may still have a crack. This could cause the propeller to disintegrate while in use. Do not use a nicked, cracked, or split propeller.
- Keep foreign objects away from the propeller. Make sure that nothing can be drawn into the propeller. Never start the engine on loose gravel or sand. Make sure there are no loose clothing or jacket strings that could be drawn into the propeller. Secure your clothing.
- Keep onlookers away from the running engine, especially small children.
- Do not attempt to stop the engine by throwing anything into the path of the propeller.
- Make sure the fuel tubing is well-secured to the engine and to the fuel tank so that it cannot come off in flight.
- Do not use silicone fuel tubing because it will be attacked by the fuel. Use fuel tubing that is suitable for gasoline.
- Always secure the fuel tubing away from the cylinder head. The engine's heat can damage the fuel tubing.
- Never touch the engine after it's been running. The engine will be hot and could cause burns.
- Remove all fuel from the fuel tank and fuel lines before transporting your model.
- Always use high-quality oil intended for two-cycle engines.
- Use only low octane, alcohol-free gasoline. The carburetor diaphragm will gradually deteriorate if you use gasoline with alcohol. You will need to replace the diaphragm in about 80 hours of operation if you use gasoline that contains alcohol. "Alcohol" includes ethanol in many gasoline blends.
- Muffler pressure to the fuel tank is not required.
- Do not install your throttle servo or kill switch servo inside the engine compartment. Doing so could cause radio interference. Install all electronic radio devices at least 12" inches [305mm] away from the engine. The throttle pushrod should be non-metallic.
- In case the engine is not to be used for more than a month, drain the fuel tank and remove any fuel from inside the carburetor. Do this by running the engine at idle until it quits by running out of fuel. Keeping gasoline for an extended time in the carburetor will damage the diaphragm valve and clog passages inside the carburetor.
- Because the carburetor is more complicated than those used in glow engines, keep the fuel clean by using a fuel filter. Use a filter intended to be used with gasoline engines. Metal filters intended for glow engines are too coarse and will not screen out finer particles. Always filter your fuel with an appropriate filter before filling the model's fuel tank.

- If you intend to run this engine on an engine stand, or on any other rigid mount, use rubber mounts. The crankcase and other parts of the engine may crack if you do not provide some kind of vibration absorption mechanism. A rubber mount is not necessary if the engine is mounted in a model airplane.
- Do not operate the engine in a closed room or where ventilation is not adequate.
- Gasoline is extremely flammable. Keep it away from an open flame, excessive heat, or sources of sparks. Do not smoke near the engine, the fuel tank, or the fuel storage can.
- This engine was designed for use in model aircraft. Do not attempt to use it for any other purpose.
- Always install a kill switch that can be operated both manually and via the R/C transmitter.

ELECTRONIC IGNITION MODULE

Your Fuji-Imvac BF-25EI or BF-34EI EIS engine is equipped with an electronic ignition module. Electronic ignition uses a battery-powered processor to sense the position of the engine's crankshaft and then cause a high-energy spark at the spark plug to fire the engine at the correct moment. The actual firing of the spark plug will change with the engine's RPM so that the engine runs its best at all RPM within its operating range.

ENGINE PREPARATION

1. Check to see that all screws and bolts are tight. Check carefully for any cracks, broken, or missing parts. Tighten or replace before proceeding.
2. Install the propeller shaft onto the flywheel.
3. Install the spark plug into the cylinder head.

SPARK PLUG

The required spark plug is a Champion NGK-CMR6A. Do not use any other type of spark plug, or possible engine damage may result. The plug gap should be set to 0.024" (0.6mm). If the plug gap is incorrect, adjust it with a spark plug gapping tool, wash it in gasoline, and allow it to dry before it's reinstalled in the engine.

PROPELLER

Always use a well-balanced, high-quality propeller.

The recommended propellers are:

22 x 10 wood, or 22 x 12 carbon

Other propellers that can be used are

18 x 8, 20 x 6

Typical operating RPM are:

20 x 6 Mejzlik Carbon Prop:

BF-25F: 1,400 – 6,600 RPM

BF-34F: 1,300 – 7,200 RPM

18 x 8 Bolly Carbon Prop:

BF-25F: 1,400 – 7,300 RPM

BF-34F: 1,300 – 7,800 RPM

Temperature for the above was 15°C, humidity was 20%. Engines were new, with 100 minutes of break-in running.

ENGINE INSTALLATION

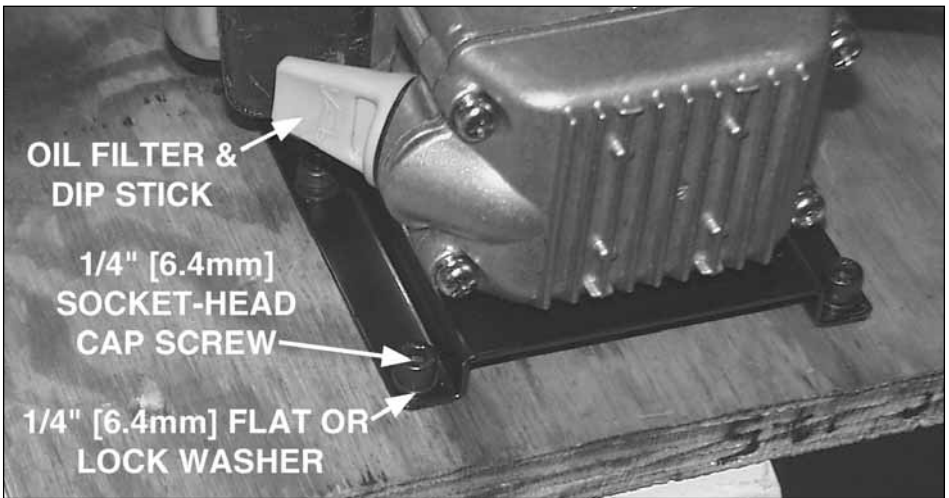

Your Fuji-Imvac BF-25EI or BF-34EI engine must be mounted on a 1/2" [12mm] lite-ply firewall or a 3/8" [9.5mm] aircraft ply firewall. The firewall must be securely-glued to the airplane. Use triangle stock, and pin the firewall with hardwood dowels to reinforce the firewall glue joints. Never install your engine onto a firewall thinner than specified because it may fail due to the engine's power.

1. Use the supplied template (on the back cover of this manual), to drill the engine mounting bolt holes.
2. Install the engine on the firewall with four 1/4" x 1'1/4" [6.4 x 32mm] socket-head cap screws, four 1/4" [6.4mm] flat or lock washers, and four 1/4" [6.4mm] blind nuts. Use threadlocking compound, such as Great Planes[®] Pro[™] Threadlocker[™] (GPMR6060) on the screws. The engine **MUST** be mounted with the cylinder head up. **DO NOT** mount the engine with the cylinder head to the side or down
3. Install the fuel tank in the airframe. Use only gasoline-safe fuel lines. With a two line fuel tank, one line should go to the carburetor, and one line is used as a vent.

You would use the carburetor fuel line as the filler line. A fuel filter should be in the fuel line that goes from the fuel tank to the carburetor. You would fill the tank from the fuel tank side of the fuel filter. If access to the carburetor fuel line is a problem, you can add a third line to the tank for a filler line. This line would be capped when it's not being used.

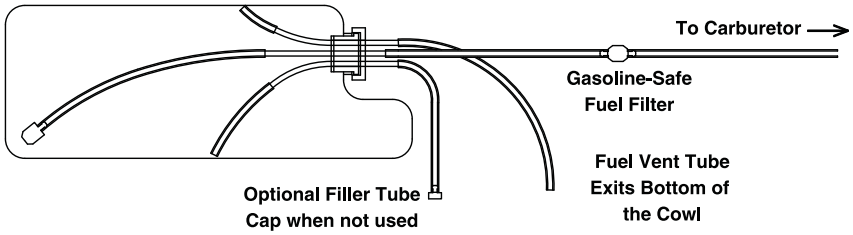

4. Install the kill switches. You will need one servo-operated switch, and one manual switch. The two kill switches will be installed between the battery pack and the EIS unit, per the diagram below. Ignore the white wire in your connections. A regular switch harness from most R/C systems will suffice for the manual kill switch.

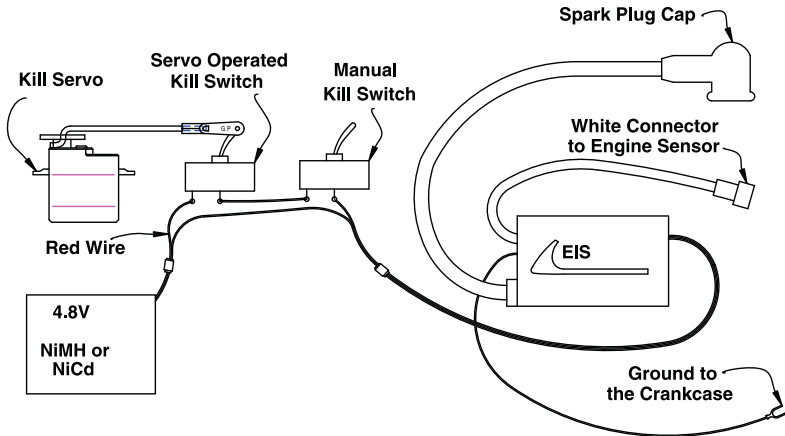

5. Make sure all of the engine wiring is as far as possible from the receiver and servos so that any possible interference from the ignition system doesn't affect them. The black wire with the "U"-shaped connector is the ground for the system. It should be secured to the crankcase with one of the engine's bolts.

6. Install the throttle servo at least 12" [305mm] away from the engine. Make sure that you get the carburetor's full range of rotation with your servo travel.

7. Cut all necessary clearance and cooling holes in the airplane's cowl. Make sure that air entering the cowling will actually go through the fins on the engine's cylinder and head. Make any baffles necessary to insure this. The air exit from the cowling should be 2-3 times larger in area than the cooling air inlets.

8. Make sure the cowl is secured to the airplane and that the spinner-to-cowl clearance is at least 1/8" [3.2mm].

BEFORE OPERATION

1. Take only the amount of gasoline needed for each operating session. Aged gasoline could damage the engine and cause it to overheat.
2. Check the oil level in the crankcase. The oil level should be between the two cross-hatched areas on the dipstick that's part of the oil filler cap. Use only Fuji-Imvac Super Lubricating oil. The BF-25EI will have a full-oil capacity of 80 ml, and the BF-34EI will have a capacity of 100 ml. This oil has an equivalent SAE rating of 0W-20.
3. If the engine was just run, make sure you allow enough time for it to cool to ambient temperature before you refuel it to run it again. A hot engine can be a fire hazard during refueling. Wipe off any oil on the airplane that may have been cast from the engine. Clean up any spilled fuel.
4. Make sure that there are no foreign objects in the path of the propeller, or that could be drawn into the propeller. Secure all articles of clothing so that they cannot be drawn into the propeller.
5. Go through the safety tips and warnings at the beginning of this instruction manual to ensure a successful and safe engine run.
6. Fill the fuel tank with unleaded automotive gasoline. Filter the fuel that goes into the model's fuel tank to prevent foreign matter from getting into the carburetor and engine.

ENGINE BREAK-IN

- Your Fuji-Imvac four-stroke engine does not require break in. It is ready to fly right out of the box.

STARTING YOUR FUJI-IMVAC BF-24EI OR BF-34EI ENGINE

There are three ways to start your engine: hand-flipping the propeller, using a spring starter, or using a hand-held electric starter.

Spring Starter

1. Fill the fuel tank with unleaded automotive gasoline. Always filter the gasoline that goes into the fuel tank.
2. With the switch in the "off" position, close the choke and rotate the propeller several times counterclockwise to draw fuel to the engine and fill the fuel lines.
3. Switch the ignition to the "on" position.
4. Open the throttle a small amount and rotate the propeller a few times counterclockwise. Hold the propeller in your fist and do not flip it. The spark plug is energized, but it won't fire because the engine isn't turning fast enough.

5. Using both hands, rotate the propeller clockwise one turn (360°). Release with both hands, moving them quickly out of the way. It is strongly recommended that you wear gloves to protect the hands against possible injury. Repeat a few times. The engine will fire and run for only a few seconds.
6. Open the choke and repeat step 5. The engine should fire and continue to run
7. Warm up the engine at low to medium RPM for one minute before proceeding with the flight.

Electric Starter

You can use a regular-size heavy-duty starter instead of a large giant-scale type of starter because the compression of the Fuji-Imvac four-stroke engines is less than that of a two-stroke engine.

1. Perform steps 1-4 of the “**Spring Starter**” procedure, above.
2. Open the throttle a small amount and rotate the propeller clockwise by hand until you feel the compression point.
3. Apply the starter. Make sure it’s turning the engine counterclockwise.
4. The engine should fire and run for a few seconds. Then open the choke and spin the engine with the starter. It should fire and continue to run.
5. Warm up the engine at low to medium RPM for one minute before proceeding with the flight.

Hand Starting

1. It’s strongly-recommended that you use an electric starter to start your Fuji-Imvac four-stroke engine when it’s brand-new. Until it’s broken-in, it will be rather difficult to start by hand.
2. Follow steps 1-4 of the “**Spring Starter**” section.
3. Slowly rotate the propeller counterclockwise several times. Hold the propeller in your fist as you turn it. If the ignition is on, you’ll feel it pulse.
4. Turn the propeller forward until you feel the compression. Back off about 30 degrees and then flip the propeller briskly through compression. The engine should fire and run for a few seconds.
5. Open the choke and flip the propeller the same way as in step 4. It should start within a few flips.

TROUBLESHOOTING

1. If the engine is flooded, the engine should be turned over rapidly with the ignition off and the throttle fully opened. If the engine is dry, put 5-6 drops of fuel directly into the carburetor.

If you can’t tell whether the engine is flooded or dry, the best way to check is to remove the spark plug. If it’s wet with raw gasoline, the engine’s flooded.

If the plug is absolutely dry, add 3-4 drops of fuel into the cylinder. Replace the plug and start the engine in the conventional manner.

2. If the engine just won't fire, it may have ignition problems. Remove the spark plug and lay it on the cylinder, but leave the ignition lead connected. Rotate the propeller rapidly and check for a spark. The engine must be turning 500 RPM or better for the EIS to generate a spark. You may need a dark or shaded area in order to see the spark.

A dirty plug won't spark. Use a spark plug cleaning brush to clean the plug.

An improperly-gapped plug won't spark. Use a spark plug tool to set the gap to the correct distance.

We recommend that you use an electric starter until you are familiar with how your engine handles.

CARBURETOR ADJUSTMENT

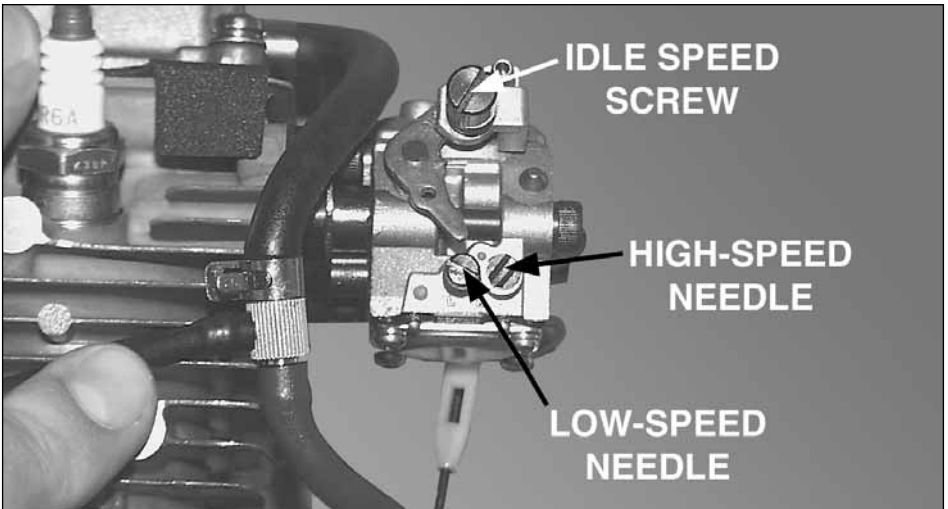

1. Idle Speed Adjustment:

Always adjust the idle speed with the engine shut off. Make sure the ignition is OFF.

Turn the idle adjust screw counterclockwise to lower the idle RPM. Turn clockwise to increase idle RPM. Turn it about 1/8-turn each time. If you try to idle the engine too slowly, it will not run.

2. High and Low-Speed Needle Adjustment:

Always make needle adjustments with the engine shut off. Make sure the ignition is OFF. Normally, only the high-speed needle will have to be adjusted from time-to-time, and it will only need a small amount of change.

The needle marked “H” is the high-speed needle. Turning the needle clockwise will lean the high-speed mixture. Turning counterclockwise will richen the high-speed mixture.

The needle marked “L” is the low-speed needle. It operates exactly like the high-speed needle.

Initial settings for both the BF-25EI and BF-34EI are:

High Speed: 1-3/4 to 2 turns out from closed.

Low Speed: 1-1/3 turns out from closed.

They would be adjusted from there, as needed. Turn no more than 1/8-turn at a time during adjusting. There can be as much as +/- 1/8-turn difference between different engines at the same location when they are properly-adjusted.

3. About the Needles:

If the high-speed needle (H) is too lean, you may find that the engine will quit, it may hesitate during rapid acceleration, and it may not reach full RPM when the throttle is fully-opened.

If the high-speed needle is too rich, full-throttle RPM will be low, and the spark plug will tend to become fouled with carbon.

If the low-speed needle (L) is too lean, the engine will hesitate and quit during acceleration, RPM will be higher at idle, or the engine will quit when throttling down.

If the low-speed needle is too rich, the idle may be unstable.

Over time, the low-speed needle won't need to be changed much, if at all, but the high-speed needle will need to be adjusted from time-to-time, depending upon air temperature and field elevation. If you visit other areas to fly, you may need to re-set the high-speed needle.

Whenever you change the size of the propeller, richen the high-speed needle about 1/4-turn before you start the engine. Get it properly re-set after the new prop is installed.

HOW TO STOP THE ENGINE

When you're finished with a flight, or in case of an emergency, you'll have to stop the engine. You can do this by: shutting off the ignition with the “kill” switch, have the throttle set so that you can close it farther than the normal idle position, close the choke valve.

With all ignition engines, you must be able to shut down the engine manually, and many users add a servo-operated switch so that the transmitter can be used to shut down the engine.

You can set the idle speed adjustment so that the throttle will close lower than the normal idle setting. You would use the throttle trim on the transmitter to lower the idle to kill the engine. If all else fails, you can close the choke. Killing the engine by idling down or using the choke will starve the engine of air, and choke it for the next flight.

3-Year Limited Warranty For USA and Canada

Fuji-Imvac Engines warrants this product to be free from defects in materials and workmanship for a period of three (3) years from the date of purchase. During that period, Fuji-Imvac Engines will, at its option, repair or replace without service charge any product deemed defective due to those causes. You will be required to provide proof of purchase date (receipt or invoice).

- This warranty does not cover damage caused by crash, abuse, misuse, alteration or accident. Damage caused by customer disassembly, tampering, use of substandard fuel, use of incorrect accessories (spark plug, prop, etc.) or any use of the engine for which it is not specifically intended will automatically void the warranty of the engine. If there is damage resulting from these causes within the stated warranty period, Fuji-Imvac Engines will, at its option, repair or replace it for a service charge not greater than 50% of the current retail list price. Be sure to include your daytime telephone number and e-mail address in case we need to contact you about your repair.
- Under no circumstances will the purchaser be entitled to consequential or incidental damages. This warranty gives you specific legal rights and you may also have other rights, which vary from state to state.
- If you attempt to disassemble or repair this unit yourself, it may void the warranty.

For service on your Fuji-Imvac Engines product, either in or out of warranty, send it post paid and insured to:

Hobby Services
3002 N. Apollo Dr., Suite 1
Champaign, IL 61822 USA
(217) 398-0007
www.hobbyservices.com

Along with your engine and proof of purchase date, please include a complete written explanation detailing the problem(s). State your name and address clearly. For repairs not covered under warranty, you must specify whether you wish the charges to be billed COD or if you wish to be notified of the charges so you can send a check.

Outside USA and Canada, contact local importer for warranty information.

Engine Exploded Views

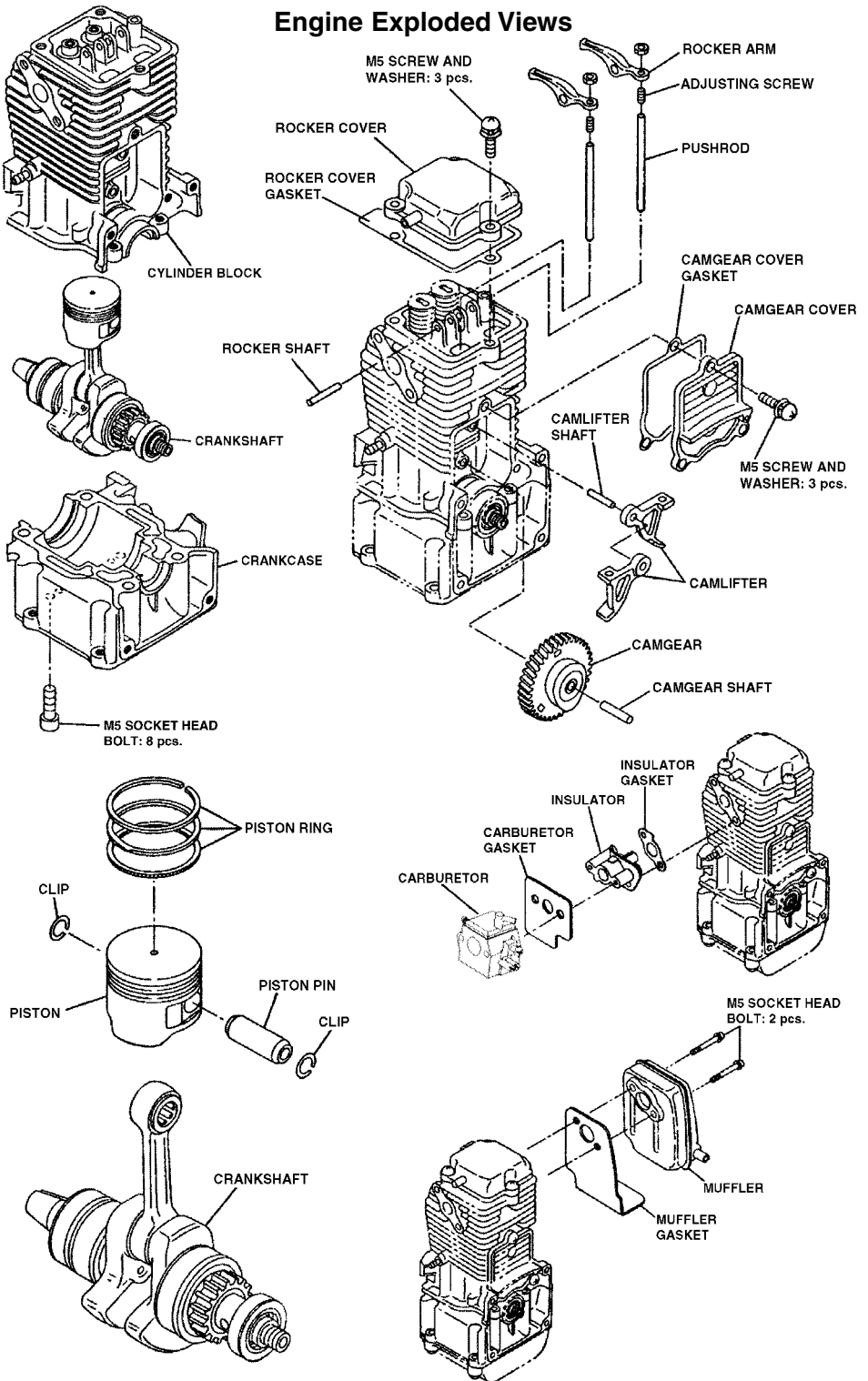

Engine Mounting Templates

