

FUJI ENGINES™

Operator's Manual for BT-24M



SPECIFICATIONS

| | |
|------------------------|---|
| Displacement: | 23.9cc (1.45 cubic inch) |
| Horsepower: | 3.0HP (2.18kw) |
| Ignition Style: | Spring-Assisted Recoil Starter |
| R.P.M.: | 4000 - 12,000RPM |
| Fuel: | Gasoline/Oil mix |
| Weight: | Approximately 1.4kg [3.13 lbs] w/Muffler |

**Manufactured by FUJI IMVAC INC.
YOKOHAMA, 235-0005 JAPAN**
**Worldwide Distributor (except Japan): Hobbico, Inc.
Champaign, IL 61826 USA**
www.fujiengines.com

SAFETY TIPS AND WARNINGS

- Always use a balanced prop. An unbalanced prop will cause high levels of vibration that may be harmful to your driveshaft and engine.
- Be sure to keep your driveshaft well lubricated. Failure to do so may cause vibrations that can be harmful to the engine. Re-lubricate your driveshaft every 2-3 runs.
- Keep foreign objects away from the propeller. Never start the engine on loose gravel or sand.
- Keep onlookers away from the running engine, especially small children.
- Do not attempt to stop the engine by throwing anything into the path of the propeller or by grabbing the driveshaft.
- Make sure the fuel line is well-secured to the engine and to the fuel tank so that it won't come off while in use.
- Do not use silicone fuel line because it will be attacked by the gasoline. Use vinyl or neoprene rubber fuel line.
- Always secure the fuel line away from the cylinder head. The engine's heat can damage the fuel line.
- Muffler pressure to the fuel tank is not required.
- Never touch the engine or exhaust system after a run. Parts of the engine and exhaust will be hot and may burn you.

- Before transporting your model, remove all of the gasoline from the tank and lines.
- Always use high quality oil intended for 2-cycle engines.
- Use only low octane, alcohol-free gasoline. The carburetor diaphragm will gradually deteriorate if you use gasoline with alcohol. You will need to replace the diaphragm in about 80 hours of operation if you use gasoline with alcohol.
- Do not install your throttle servo inside the engine compartment. Doing so could cause radio interference. Install all electronic radio devices at least 12" [305mm] away from the engine.
- If you are not planning to run your engine for more than a month, drain the fuel tank and remove any fuel from inside the carburetor. Do this by running the engine at idle until it quits by running out of fuel. Keeping gasoline inside the carburetor over an extended period of time will damage the diaphragm valve and clog passages inside the carburetor.
- Because the carburetor is more complicated than those used in glow engines, keep the fuel clean by using a fuel filter. Use a filter intended to be used with gasoline engines. Metal filters intended for glow engines are too coarse and will not screen out finer particles.
- If you intend to run this engine on an engine stand, or on any other rigid mount, use hard rubber isolation mounts. The crankcase and other parts of the engine may crack if you do not provide some kind of vibration absorption mechanism.
- Do not operate the engine in a closed room or where ventilation is not adequate.
- Gasoline is extremely flammable. Keep it away from an open flame, excessive heat or sources of sparks. Do not smoke or allow anyone else to smoke near the engine or the fuel tank.
- This engine was designed for use in model boats. Do not attempt to use it for any other purpose.

PREPARING THE ENGINE

1. Check to see that all screws and bolts are tight. Check carefully for any cracks, broken or missing parts. Tighten or replace before proceeding.
2. Install the spark plug in the cylinder head.

SPARK PLUG

The recommended spark plug is a Champion RCJ-6Y. To avoid improper operation or possible engine damage, do not use any other type of spark plugs. The plug gap should be 0.016" to 0.024" [0.4mm to 0.6mm]. If the plug gap is incorrect, adjust it with a spark plug gapping tool, wash it with gasoline and allow it to dry completely before you reinstall the plug in the engine.

INSTALLING THE FUJI BT-24M IN YOUR BOAT

Note: The Fuji BT-24M must be installed onto mounting rails which are then mounted to your hull's mounting lugs. Use hard rubber isolation mounts between the mounting rails and lugs. The instructions listed here describe a typical gas boat installation and do not necessarily apply to all makes and models. It is a good idea to consult your hull manufacturer's instruction manual for proper mounting procedure.

1. Place the BT-24M on your boat's mounting rails. Mark and drill the engine mounting bolt holes on the mounting rails.
2. Fasten the engine onto mounting rails using four 4MM socket head cap screws and four 4MM lock washers. It is a good idea to use some thread locking compound, such as Great Planes® Pro Thread Locking Compound (GPMR6060), on the screws.
3. Install the engine and mounting assembly into your boat. (Consult the manual that came with your hull for proper mounting position)
4. Attach the fuel line to the carburetor. It is a good idea to use a retaining clip to hold the line in place. Use only gasoline-safe fuel line. One line should go to the carburetor and the other is to be used as a vent. You can fill the tank by using the carburetor line as fill line if you have access to it or install a third line to be used as fill line.
5. Install the throttle servo at least 12" [305mm] away from the engine. Make sure that you get the carburetor's full range of rotation with your servo travel.
6. Attach the water cooling lines to the cylinder head.

Optional:

7. Mount a kill switch in a secure manner inside the engine compartment. Make sure that it is easily accessible and away from engine components that may be hot.

BEFORE OPERATION

- Go through the safety tips and warnings at the beginning of this manual to ensure a successful and safe engine run.
- Prepare only the amount of gasoline needed. Aged gasoline could damage the engine and cause it to overheat.
- If the engine was just run, make sure you allow enough time for it to cool down before you run it again. It is important to clean up any excess fuel that may have leaked inside the hull.
- Check to see that there are no foreign objects in the path of the propeller. Secure any loose articles of clothing so they cannot be drawn into the propeller.
- Fill the boat's fuel tank with the adequate gasoline mix.

BREAK IN THE ENGINE

To break-in your BT-24M, you need to run the engine for about an hour with a fuel mixture that contains a 25:1 (4% oil) fuel/oil ratio. The engine's output power will increase gradually over the first few tanks.

- Do not adjust the high-speed needle on the carburetor to break in the engine. If you do so, carbon will accumulate in the spark plug and that will make ignition difficult.
- Do not run at full power for extended periods of time while breaking in your engine.
- Make sure that the engine has adequate cooling.

RUNNING THE FUJI BT-24M IN YOUR BOAT

Once the engine is broken in, use 40:1 (2.5% oil) fuel/oil mix.

STARTING PROCEDURE

Helpful Tip: It is a good idea to have someone hold the boat in place while you start the engine.

1. Depress the priming bulb 3-5 times. This will begin the flow of fuel into the carburetor.
2. Close the choke on the carburetor and pull the handle of the recoil starter until you hear some initial firing sounds.
3. Quickly open the choke and pull the handle of the recoil starter until the engine starts.
4. After starting, let the engine idle for 30 seconds. Open and close the throttle slowly until the engine runs smoothly at idle and at full throttle. Acceleration should also be smooth.
5. If your engine does not start, repeat the starting procedure.

ENGINE ADJUSTMENTS

- Always make high and low speed needle adjustments while the engine is not running.
- Adjust the needle marked "H" for high speed RPM. Adjust the needle marked "L" for low speed RPM.

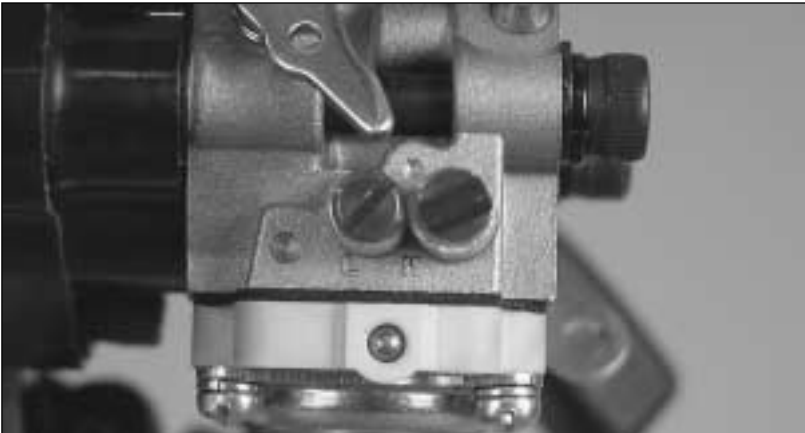

Normal high and low-speed needle settings:

It is not necessary to change the needle settings if the engine runs smoothly. Normally only the "H" needle will need adjustment from time to time and only by a small amount.

H: Open the needle 3/4 of a turn from the closed position ($\pm 1/4$ of a turn in cold weather).

L: Open the needle 1-3/8 turns from the closed position ($\pm 1/4$ of a turn in cold weather).

Only adjust the high and low speed needle within the above range.

Idle adjustment:

Important: Do not confuse the idle screw with the low speed needle “L”. The idle screw physically adjusts how much the carburetor valve can close. The low speed needle “L” adjusts the gasoline to air mixture when the engine is running at low rpm. If your engine appears to work correctly except that the low rpm are not as low as you want them to be, then adjust the idle screw. If your engine behaves erratically at low rpm, then adjust the low speed needle “L”. When adjusting, turn the screw about 1/8 of a turn each time. A dirty plug will make it difficult to adjust the idle RPM. Follow the recommended procedures if any of the following happens:

Problem:

- The engine hesitates when accelerated rapidly.
- The RPM increases at idling.
- The engine stops when the throttle is moved from high to low.

Solution:

Your low speed needle “L” is too lean. Open it up about 1/8 of a turn and try again.

Problem:

- The idle is not steady.

Solution:

Your low speed needle “L” valve is too rich. Close it 1/8 of a turn and try again.

High Speed Adjustment:

The high speed rpm and transition performance is adjusted with the high speed “H” needle valve. When adjusting, turn the screw about 1/8 of a turn each time. The position of the “H” needle will vary according to temperature and elevation. If your engine is running smoothly then do not adjust this needle valve. Follow the recommended procedures if any of the following happens:

Problem:

- Engine stops at full throttle.
- Engine hesitates when accelerated rapidly.
- The engine will not come up to full RPM at full throttle.

Solution:

Your high speed needle valve “H” is too lean. Open it up 1/8 of a turn and try again.

Problem:

- Your engine does not reach full rpm.
- Carbon build-ups appear consistently on your spark plug.

Solution:

Your high speed needle valve “H” is too rich. Close it up 1/8 turn and try again.

3-Year Limited Warranty For USA and Canada

Fuji Engines warrants this product to be free from defects in materials and workmanship for a period of three (3) years from the date of purchase. During that period, Fuji Engines will, at its option repair or replace without service charge any product deemed defective due to those causes. You will be required to provide proof of purchase date (receipt or invoice).

- This warranty does not cover damage caused by crash, abuse, misuse, alteration or accident. Damage caused by customer disassembly, tampering, use of substandard fuel, use of incorrect accessories (spark plug, prop, etc.) or any use of the engine for which it is not specifically intended will automatically void the warranty of the engine. If there is damage resulting from these causes within the stated warranty period, Fuji Engines will, at its option, repair or replace it for a service charge not greater than 50% of the current retail list price. Be sure to include your daytime telephone number and e-mail address in case we need to contact you about your repair.
- Under no circumstances will the purchaser be entitled to consequential or incidental damages. This warranty gives you specific legal rights and you may also have other rights, which vary from state to state.
- If you attempt to disassemble or repair this unit yourself, it may void the warranty.

For service on your Fuji Engines product, either in or out of warranty, send it post paid and insured to:

Hobby Services
3002 N. Apollo Drive, Suite 1
Champaign, Il 61822 U.S.A.
(217) 398-0007
www.hobbyservices.com

Along with your engine and proof of purchase date, please include a complete written explanation detailing the problem(s) and a phone number that you can be reached at during the day. State your name and return address clearly. For repairs not covered under warranty, you must specify whether you wish the charges to be billed COD or if you wish to be notified of the charges so you can send a check.

Outside USA and Canada, contact local importer for warranty information.

REPLACEMENT PARTS LIST CYLINDER/PISTON/CRANKSHAFT

| Key # | Part # | Description |
|-------|----------|-------------------------|
| 1 | FJIG7470 | Spark Plug RCJ-6Y |
| 2 | FJIG4441 | Cylinder Set |
| 3 | FJIG8290 | Hex Bolt 5x18/S |
| 4 | FJIG4291 | Cylinder Gasket |
| 5 | FJIG6635 | Piston Ring |
| 6 | FJIG6361 | Piston Set |
| 7 | FJIG6419 | Piston Pin |
| 8 | FJIG6509 | Piston Pin Circlip |
| 9 | FJIG8719 | Water Jacket Complete |
| 10 | FJIG7160 | Screw 3x8 |
| 11 | FJIG4019 | Crankshaft Complete |
| 12 | FJIG6149 | Needle Bearing 1.4x8.5 |
| 13 | FJIG7660 | Woodruff Key |
| 14 | FJIG6260 | O-Ring |
| 15 | FJIG7500 | Spark Plug Cap Assembly |

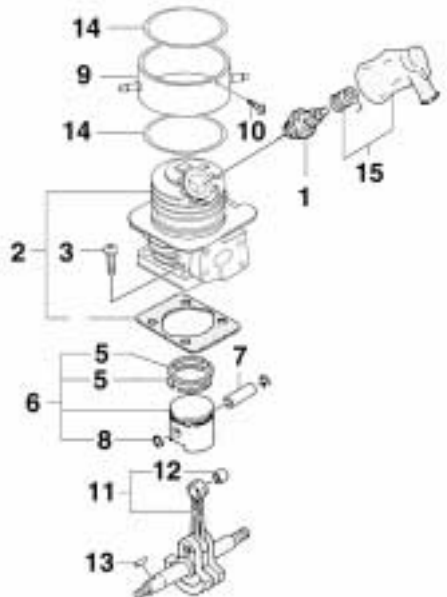

CRANKCASE

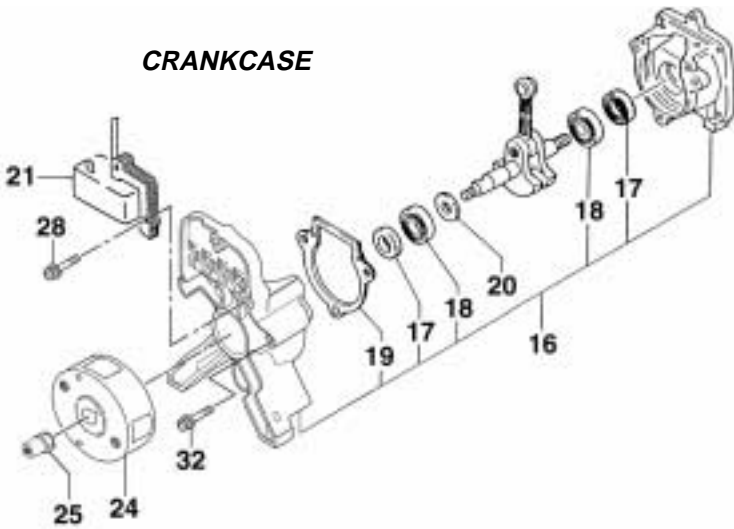

| Key # | Part # | Description | |
|-------|----------|----------------------|--|
| 16 | FJIG3830 | Crankcase Assembly | 20*FJIG7312Gear Shaft Shim 0.20 |
| 17 | FJIG6300 | Oil Seal TB12227 | 20*FJIG7313Gear Shaft Shim 0.30 |
| 18 | FJIG3080 | Ball Bearing 6001 C3 | 21FJIG5315Ignition Coil Complete |
| 19 | FJIG3920 | Crankcase Gasket | 24FJIG0020Magneto Rotor 60mm |
| 20* | FJIG7310 | Gear Shaft Shim 0.10 | 25FJIG0020Adapter |
| 20* | FJIG7311 | Gear Shaft Shim 0.15 | 28FJIG8220Hex Hole Bolt 4x18WS |
| | | | 32FJIG8290Hex Hole Bolt 5x18S |

CARBURETOR COMPLETE

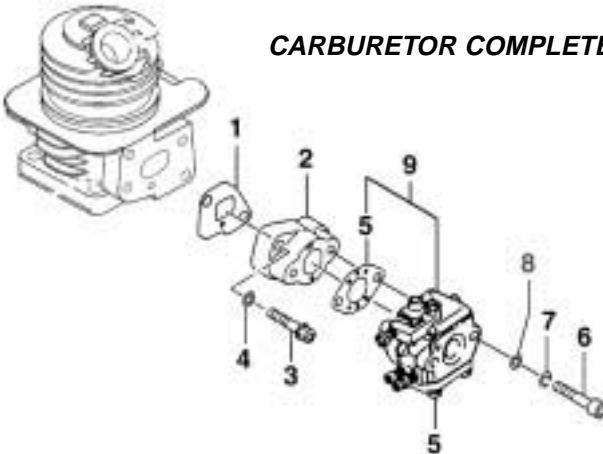

| Key # | Part # | Description | |
|-------|----------|----------------------|---|
| 1 | FJIG5480 | Insulator Gasket | 5FJIG3110Carburetor Gasket |
| 2 | FJIG5515 | Insulator Set | 6FJIG8340Hex Hole Bolt 5x50 |
| 3 | FJIG8305 | Hex Hole Bolt 5x22/S | 7FJIG8605Washer 5mm |
| 4 | FJIG8645 | Small Washer 5mm | 8FJIG8645Small Washer 5mm |
| | | | 9FJIG3230Carburetor Set |

RECOIL STARTER

| Key # | Part # | Description |
|-------|----------|----------------------------|
| 2 | FJIG5460 | Inlet Screen |
| 0 | FJIG7130 | Recoil Start Body Assembly |
| 1 | FJIG7134 | Starter Handle |
| 2 | FJIG7131 | Recoil Start Body Complete |
| 3 | FJIG7132 | Recoil Rope |
| 4 | FJIG7133 | Recoil Spring |
| 6 | FJIG7135 | Spring Case |
| 8 | FJIG7136 | Starter Pulley |
| 9 | FJIG8606 | Special Washer 5.2x15 |
| 10 | FJIG7164 | Tapping Screw 5x14 |
| 15 | FJIG7137 | Starter Base |
| 16 | FJIG7162 | Tapping Screw 4.5x14 |
| 17 | FJIG8190 | Hex Hole Bolt 4x12WS |
| 20 | FJIG7138 | Starter Pulley Assembly |

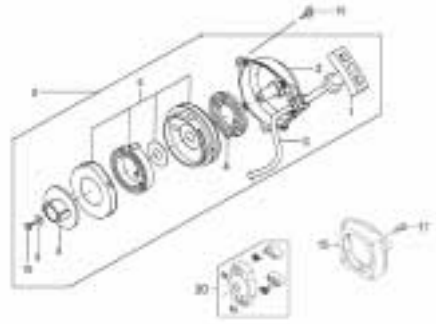

CARBURETOR

| Key # | Part # | Description |
|-------|----------|-------------------------|
| 2 | FJIG5460 | Inlet Screen |
| 3 | FJIG6930 | Pump Body |
| 4 | FJIG7170 | Set Screw |
| 5 | FJIG7060 | Pump Gasket |
| 6 | FJIG7020 | Pump Diaphragm |
| 7 | FJIG4610 | Diaphragm Gasket |
| 8 | FJIG5760 | Metering Diaphragm Comp |
| 9 | FJIG3020 | Air Purge Comp |
| 10 | FJIG4520 | Diaphragm Cover |
| 11 | FJIG6210 | Priming Body |
| 12 | FJIG8525 | Valve Spring |
| 13 | FJIG6240 | Needle Valve |
| 15 | FJIG7540 | Valve Hinge |
| 16 | FJIG5130 | Hinge Pin Set Screw |
| 17 | FJIG5100 | Hinge Pin |
| 18 | FJIG5220 | Idle Adjust Screw |
| 19 | FJIG5285 | Idle Adjust Spring |
| 27 | FJIG7161 | Set Screw |
| 28 | FJIG5070 | High/Low Adjust Spring |
| 29 | FJIG5590 | Low Adjust Screw |
| 30 | FJIG5040 | High Adjust Spring |
| 31 | FJIG4940 | High Adjust Screw |

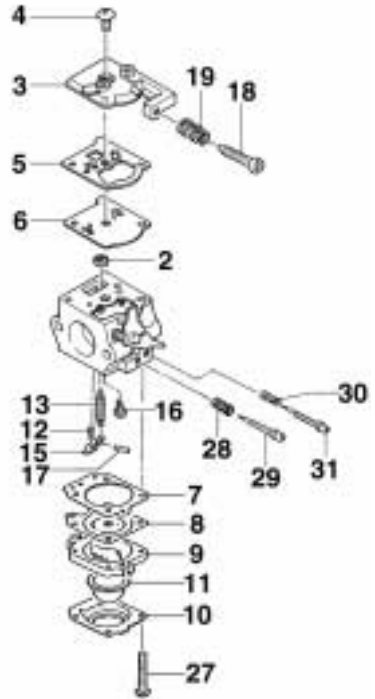

OPTIONAL MUFFLER & ACCESSORIES

| | |
|----------|--------------------|
| FJIG5990 | Muffler Set |
| GPMG2150 | Engine Kill Switch |

| Key # | Part # | Description |
|-------|----------|------------------------|
| 1 | FJIG5810 | Muffler Gasket |
| 3 | FJIG8120 | Hex Hole Bolt 5x70 |
| 4 | FJIG8606 | Special Washer B |
| 5 | FJIG5991 | Muffler Special Gasket |
| 6 | FJIG8710 | Tail Pipe Set |
| 7 | FJIG7165 | Screw 4x8/S |
| 8 | FJIZ1140 | Instruction Manual |
| 9 | FJIG3680 | Combi Box Spanner |
| 11 | FJIG7166 | Screw 4x16/PS |

