

FUJI IMVAC™

Operator's Manual for BT-86EI

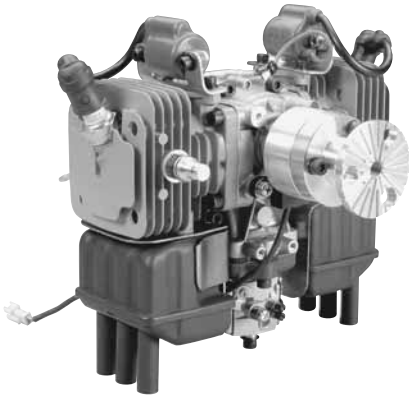

SPECIFICATIONS

Displacement:	5.25 cu in [86.0cc]
Output:	7.5hp @ 8,500 rpm
Ignition Style:	Electronic Ignition System
RPM:	1,100 – 8,500
Fuel:	Gas/2-cycle engine oil
Weight w/Mufflers:	7.5 lb [3.3kg]

**Manufactured by FUJI-IMVAC INC.
YOKOHAMA, 235-0005 JAPAN**
**Worldwide Distributor (except Japan): Hobbico, Inc.
Champaign, IL 61826 USA**
www.fuji-imvac.com

Fuji-Imvac is not related to the original Fuji Engines sold by Mecoa.

SAFETY TIPS AND WARNINGS

- Always use a balanced spinner and a balanced prop. An unbalanced spinner and prop combination will cause high levels of vibration and may cause the propeller shaft to break.
- Always use a lightweight spinner on your engine. Lightweight spinners are considered to be those with a cone wall of 1mm or less. Heavy spinners could cause the propeller shaft to break.
- Securely tighten the spinner and prop on the engine to prevent it from being thrown off the engine while running.
- Never use a prop that has hit the ground. Even though it may look good from the outside, it may be cracked on the inside which may cause it to disintegrate while in use. Do not use a nicked, cracked or split propeller.
- Keep foreign objects away from the propeller. Make sure that nothing can be “sucked in” by the propeller. Never start the engine on loose gravel or sand.
- Keep onlookers away from the running engine, especially small children.
- Do not attempt to stop the engine by throwing anything into the path of the propeller.
- Make sure the fuel line is well-secured to the engine and to the fuel tank so that it won't come off in flight.

- Do not use silicone fuel line because it will be attacked by the fuel. Use vinyl or neoprene rubber fuel line.
- Always secure the fuel line away from the cylinder head. The engine's heat can damage the fuel line.
- Never touch the engine after a run. The engine will be hot and it may burn you.
- Before transporting your model, remove all the fuel from the fuel tank and fuel lines.
- Always use high-quality oil intended for 2-stroke engines.
- Use only low-octane, alcohol-free gasoline. The carburetor diaphragm will gradually deteriorate if you use gasoline with alcohol (ethanol, gasohol, etc.). You will need to replace the diaphragm in about 80 hours of operation if you use gasoline with alcohol.
- Muffler pressure to the fuel tank is not required.
- Do not install your throttle servo or kill switch servo inside the engine compartment. Doing so could cause radio interference. Install all electronic radio devices at least 305mm [12"] away from the engine. The throttle pushrod should be non-metallic.
- In case the engine is not to be used for more than a month, drain the fuel tank and remove any fuel from inside the carburetor. Do this by running the engine at idle until it runs out of fuel. Keeping gasoline inside the carburetor over an extended period of time will damage the diaphragm valve and clog passages inside the carburetor.
- Because the carburetor is more complicated than those used in glow engines, keep the fuel clean by using a fuel filter. Use a filter intended to be used with gasoline engines. Metal filters intended for glow engines are too coarse and will not screen out finer particles. Always filter your fuel by using an appropriate filter before putting it into the airplane's fuel tank.
- If you intend to run this engine on an engine stand, or on any other rigid mount, use rubber mounts. The crankcase and other parts of the engine may crack if you do not provide some kind of vibration absorption mechanism. A rubber mount is not necessary if the engine is mounted on a model airplane.
- Do not operate the engine in a closed room or where ventilation is not adequate.
- Gasoline is extremely flammable. Keep it away from an open flame, excessive heat or sources of sparks. Do not smoke near the engine or the fuel tank.
- This engine was designed for use in a model aircraft. Do not attempt to use it for any other purpose.
- Always install a kill switch that can be operated manually and with the R/C transmitter.

PARTS LIST

BT-86EI Engine	Muffler Gasket (2)
Electronic Ignition Module	5x22mm SHCS with Lock Washers
50mm EIS Propeller Flange with	and Washers (4)
Propeller Washer	5x12mm SHCS with Lock Washers (5)
10mm Propeller Bolt	Spark Plug Wrench
10mm Propeller Bolt with Inner	4mm Allen Wrench.
Threading	Threadlocking Compound
Engine Mount	EIS Fuji-Imvac Decal
Muffler (2)	

FEATURES

- Automatic Ignition Timing: The BT-86EI features an Electronic Ignition System™ (EIS) that advances the ignition timing as the engine rpm increases. This ensures a delayed ignition timing at low rpm for easy starts and good low-end engine performance, and advanced timing at high rpm for good high-end power.
- The ignition module is waterproof.
- The ignition module runs on any 4.8V battery. The current consumption is approximately 320mAh.
- An optional Digital Tachometer (FJIG9920) is available to monitor rpm and ignition battery voltage.

SPARK PLUG

The recommended spark plug is a Champion RCJ-6Y or 7Y. To avoid improper operation or possible engine damage, do not use any other type of spark plugs. The plug gap should be 0.4mm to 0.6mm [0.016" to 0.024"]. If the plug gap is incorrect, adjust it with a spark plug gapping tool, wash it with gasoline and allow it to dry completely before you reinstall the plug in the engine.

Note: If you want to check if the spark plug works, remove the spark plug from the engine, connect it to the coil and make sure the metallic threaded end of the spark plug touches the engine. Spin the propeller rapidly through top dead center and check for a spark. This procedure only works in a dark room as there is too much light outside to see the spark.

The various spark plug manufacturers have much information on their web sites regarding spark plug performance and health. For more information, check:

<http://www.championsparkplugs.com/sparkplug411.asp>

PROPELLER

Always use a well-balanced, high-quality propeller.

The recommended propellers are:

22" x 8", 22" x 10", 22" x 12",
24" x 8", 22" x 12"
Carbon Prop

During our tests, our Fuji-Imvac BT-86EI turned a Bolly 22" x 12" carbon prop at 7400. The engine was new with 60 minutes of breaking in. The test conditions were: Temperature 10°C [50°F], humidity 40%, elevation at sea level. Performance may vary depending on atmospheric conditions.

OIL

Fuji-Imvac has developed a special oil to work with their engines. This oil is of extremely high quality and it has exceptional lubricating properties. This oil can be mixed with gasoline at much higher ratios than other engine oils which allows the engine to develop more horsepower and last longer. It is recommended that you use Fuji-Imvac oil with all your Fuji-Imvac. Break-in procedures are slightly different than those when using standard oils. Please refer to the table below for oil contents. Fuji-Imvac Oil bottles of different sizes are available from your Fuji-Imvac distributor or hobby shop.

- Break-in (Stage 1): 1 gallon of gasoline with 50:1 (2%) oil content.
- Break-in (Stage 2): 1 gallon of gasoline with 100:1 (1%) oil content.
- Normal running: In un-cowled or well-cooled installations 150:1 (0.65%) oil content.
- In-cowled or not-so-good cooling installations 100:1 (1%) oil content.
- Do not try to use these engine oil ratios with any other brand of oil other than the Fuji-Imvac oil.
- Do not use the Fuji-Imvac oil with any other brand of engines.
- If you have been running the engine on other oil and wish to switch to Fuji-Imvac oil, follow the break-in procedure for Fuji-Imvac oil.

If Fuji-Imvac oil is not available, or if you prefer to use a different brand of oil, use the standard fuel/oil ratios as shown below. Never experiment with cheap oil or with obscure brand names. Be certain to select only high-quality oil that is intended for use in gasoline R/C model airplane engines.

- Break-in: 1 gallon of gasoline with 25:1 (4%) oil content ratio.
- Normal running: 40:1 (2.5%) oil content ratio.

PREPARE THE ENGINE

1. Check to see that all screws and bolts are tight. Check carefully for any cracks, broken or missing parts. Tighten or replace before proceeding.

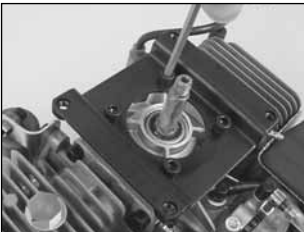

2. Install the engine mount to the engine using four 5 x 12mm SCHS. Use some threadlocking compound on the screws and make sure the screws are tight.

3. Install the prop shaft on the flywheel using three 5 x 22mm SHCS with lock washers and washers. Use threadlocking compound on the screws.



4. Install the spark plugs in the cylinder heads and tighten.

5. Secure the ignition control module ground wire to the engine as shown above.



6. Connect the ignition control module to the pick up sensor. The connector is polarized and will only plug in one way.

7. Connect the red coil wires to the ignition module. Both cylinders fire at the same time so the wires are not cylinder specific.

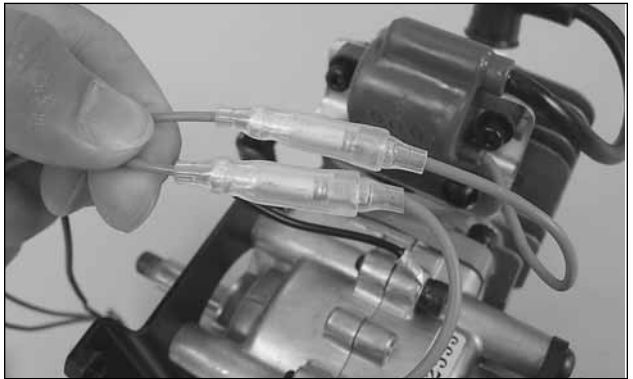

8. Connect a kill switch to the ignition control module. It is recommended to install a manual switch and a servo-operated switch. This can be accomplished using two receiver ON/OFF switches.

9. Connect the ignition module battery to the kill switch. Any 4.8V battery of 600mAh or more capacity will work well for this. The approximate current consumption of the ignition switch module is 320mAh.

INSTALLING THE FUJI-IMVAC BT-86EI ON YOUR AIRPLANE

Note: The Fuji-Imvac BT-86EI must be installed on a 12mm [1/2"] lite ply firewall or on a 9.5mm [3/8"] birch ply firewall. The firewall must be securely glued to the airplane. Use triangle stock and pin the firewall with hardwood dowels to reinforce the firewall glue joints. **Never** install the Fuji-Imvac BT-86EI onto a firewall thinner than specified because it may fail due to the power of the engine.

Note: The length of the engine from the back on the engine mount to the propeller washer is 171mm [6.7"] when using the stock (50mm [2"]) prop flange.

1. Use the supplied template (on the back cover of this manual) to drill the engine mounting bolt holes and the necessary clearance hole on the firewall.
2. Install the engine on the firewall using four 5 x 20mm socket head cap screws, four 5mm flat and four 5mm lock washers. Use some threadlocking compound, such as Great Planes® Pro™ Threadlocker (GPMR6060), on the screws.
3. Install the fuel tank in the airframe. Use only gasoline-safe fuel lines. One line should go to the carburetor and the other is to be used as a vent. You can fill the tank by using the carburetor line as fill line if you have access to it or install a third line to be used as fill line.
4. Install a manual kill switch and a radio-operated kill switch. Install the kill switch servo at least 305mm [12"] away from the engine.
5. Install the throttle servo at least 305mm [12"] away from the engine. Make sure that you get the carburetor's full range of rotation with your servo travel.
6. Install the ignition module securely in the airplane forward area. It is recommended that a thin piece of foam rubber is placed between the module and the mounting surface and that rubber bands are used to hold the module in place. 4mm screws and washers can also be used to secure it in place, but soft mounting the module is always the best choice.
7. Secure all connections with shrink tubing.
8. Cut all necessary clearance and cooling holes in the cowl.
9. Make sure the cowl is secured to the airplane and that the spinner to cowl clearance is at least 3.2mm [1/8"].

BREAK IN THE ENGINE

- The break-in procedures for your engine will vary depending on the type of engine oil you will use. Please refer to the "Oil" section for fuel/oil mixture ratios and break-in times.
- Do not adjust the high-speed needle on the carburetor to break in the engine. If you do so, carbon will accumulate in the spark plug and that will make ignition difficult.
- Do not run at full power for extended periods of time while breaking in your engine.
- Make sure that the engine has adequate cooling. While breaking in, the engine may run at slightly higher temperatures.
- If you wish to do so, you can break in your Fuji-Imvac BT-86EI while flying your airplane. Just make sure you observe all recommendations above.

STARTING PROCEDURES

There are four recommended ways to start the Fuji-Imvac BT-86EI:

A. Manual Starting:

Note: Use a thick glove to protect your hand while hand starting the Fuji-Imvac BT-86EI.

1. The propeller should be installed on the prop spacer so that it is comfortable for you to flip it through compression. You also need to position it in a way that when you flip the propeller, the magnets are 20° clockwise from the magnet pick up.
2. Have someone help you hold the airplane while you start the engine.
3. Make sure the ignition is OFF, close the choke on the carburetor and open the throttle slightly from the idle position.

4. Rotate the propeller slowly about 10 to 20 times (more in winter) until fuel begins to be drawn into the carburetor. Another way to prime the engine is to rotate the prop clockwise from bottom dead center to top dead center (compression) and then counterclockwise back to bottom dead center repeatedly.
5. Switch the ignition to ON.
6. Flip the propeller clockwise several times briskly.
7. After you hear some initial firing sounds, move the choke lever to the OPEN position.
8. Set the throttle to high idle. Set the prop so that the magnets are 20° clockwise from the magnet pick up when viewed from the front.
9. Flip the prop through compression rapidly. If this is done properly, the engine will start between the first and the eighth flip of the prop. During our testing, starting took an average of 4-6 flips.
10. After starting, let the engine idle for two to three minutes. Open and close the throttle slowly until the engine runs smoothly at idle and at full throttle. Acceleration should also be smooth.
11. If your engine does not start, repeat the procedure.

B. Electric Starter Use:

1. Make sure you use a good quality, lightweight aluminum spinner.
2. Have someone help you hold the airplane while you start it.
3. Make sure the ignition is OFF, close the choke plate on the carburetor and open the throttle slightly from the idle position.
4. Use your electric starter to turn the engine over for several seconds.
5. Switch the ignition to ON and open the choke.
6. Set the throttle to high idle and use your electric starter to turn over the engine until it starts.
7. After starting, let the engine idle for two to three minutes. Open and close the throttle slowly until the engine runs smoothly at idle and at full throttle. Acceleration should also be smooth.
8. If your engine does not start, repeat the procedure.

C. Spring Starting:

1. Have someone help you hold the airplane while you start it.
2. With the ignition OFF, close the choke plate on the carburetor and open the throttle slightly from the idle position.
3. Rotate the propeller slowly about 10 to 20 times (more in winter) until fuel begins to be drawn into the carburetor. Another way to prime the engine is to rotate the prop clockwise from bottom dead center to top dead center (compression) and then counterclockwise back to bottom dead center repeatedly.
4. Turn the ignition switch to the ON position.
5. Hold the propeller, turn it 360° clockwise (one full turn) and let it go (move hand quickly away from the propeller arc).
6. After you hear some initial firing sounds, move the choke to the OPEN position.
7. Repeat Step 5 until your engine starts.

D. Onboard Electric Starter Use:

Follow the instructions supplied with the onboard electric starter.

ENGINE ADJUSTMENTS

- Always make high- and low-speed needle adjustments with the engine shut off. Also make sure the ignition is OFF.
- Adjust the needle marked “H” for high-speed Rpm. Adjust the needle marked “L” for low-speed Rpm.

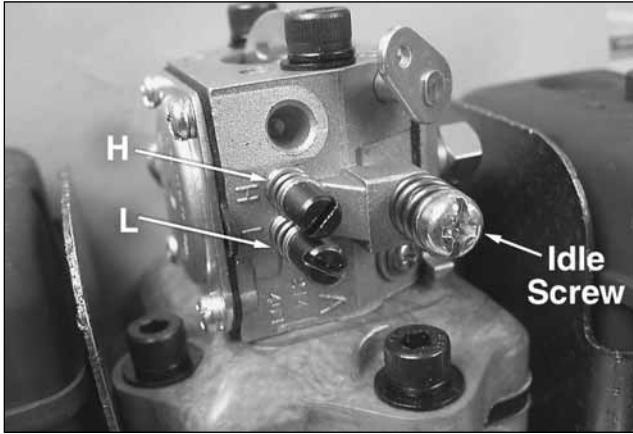

A. Normal high- and low-speed needle settings:

It is not necessary to change the needle settings if the engine runs smoothly. Normally only the “H” needle will need adjustment from time to time and only by a small amount.

H: Open the needle 3/4 of a turn from the closed position ($\pm 1/4$ of a turn in winter).

L: Open the needle 1-3/8 turns from the closed position ($\pm 1/4$ of a turn in winter).

Only adjust the high- and low-speed needle within the above range.

B. Idle adjustment:

Note: Do not confuse the idle screw with the low-speed needle “L”. The idle screw physically adjusts how much the carburetor valve can close. The low-speed needle “L” adjusts the gasoline to air mixture when the engine is running at low rpm. If your engine appears to work correctly except that the low rpm are not as low as you want them to be, then adjust the idle screw. If your engine behaves erratically at low rpm, then adjust the low-speed needle “L”. When adjusting, turn the screw about 1/8 of a turn each time. A dirty plug will make it difficult to adjust the idle Rpm. Follow the recommended procedures if any of the following happens:

Problem:

1. The engine hesitates when accelerated rapidly.
2. The Rpm increases at idling.
3. The engine stops when the throttle is moved from high to low.

Solution:

Your low-speed needle “L” is too lean. Open it up about 1/8 turn and try again.

Problem:

The idle is not steady.

Solution:

Your low-speed needle "L" valve is too rich. Close it 1/8 turn and try again.

C. High-Speed Adjustment:

The high-speed rpm and transition performance is adjusted with the high-speed "H" needle valve. When adjusting, turn the screw about 1/8 of a turn each time. The position of the "H" needle will vary according to air temperature and field elevation. If your engine is running smoothly, then do not adjust this needle valve. Follow the recommended procedures if any of the following happens:

Problem:

1. Engine stops at full throttle.
2. Engine hesitates when accelerated rapidly.
3. The engine will not come up to full Rpm at full throttle.

Solution:

Your high-speed needle valve "H" is too lean. Open it 1/8 turn and try again.

Problem:

1. Your engine does not reach full rpm.
2. Carbon build-ups appear consistently on your spark plug.

Solution:

Your high-speed needle valve "H" is too rich. Close it 1/8 turn and try again.

3-Year Limited Warranty For USA and Canada

Fuji-Imvac warrants this product to be free from defects in materials and workmanship for a period of three (3) years from the date of purchase. During that period, Fuji-Imvac will, at its option, repair or replace without service charge any product deemed defective due to those causes. You will be required to provide proof of purchase date (receipt or invoice).

- This warranty does not cover damage caused by crash, abuse, misuse, alteration or accident. Damage caused by customer disassembly, tampering, use of substandard fuel, use of incorrect accessories (spark plug, prop, etc.) or any use of the engine for which it is not specifically intended will automatically void the warranty of the engine. If there is damage resulting from these causes within the stated warranty period, Fuji-Imvac will, at its option, repair or replace it for a service charge not greater than 50% of the current retail list price. Be sure to include your daytime telephone number and e-mail address in case we need to contact you about your repair.
- Under no circumstances will the purchaser be entitled to consequential or incidental damages. This warranty gives you specific legal rights and you may also have other rights, which vary from state to state.
- If you attempt to disassemble or repair this unit yourself, it may void the warranty.

For service on your Fuji-Imvac engine, either in or out of warranty, send it postpaid and insured to:

Hobby Services
3002 N. Apollo Dr., Suite #1
Champaign, IL 61822 USA
(217) 398-0007
www.hobbyservices.com

Along with your engine and proof of purchase date, please include a complete written explanation detailing the problem(s). State your name and address clearly. For repairs not covered under warranty, you must specify whether you wish the charges to be billed COD or if you wish to be notified of the charges so you can send a check.

Outside USA and Canada, contact local importer for warranty information.

REPLACEMENT PARTS

To order replacement parts for the Fuji-Imvac BT-86EI, use the order numbers in the **Replacement Parts Lists** that follow. Replacement parts are available only as listed. Replacement parts are not available from Product Support, but can be purchased from hobby shops or mail order/Internet order firms. If you need assistance locating a dealer to purchase parts, visit www.greatplanes.com and click on **“Where to Buy.”**

CYLINDER/PISTON/CRANKSHAFT PARTS LIST

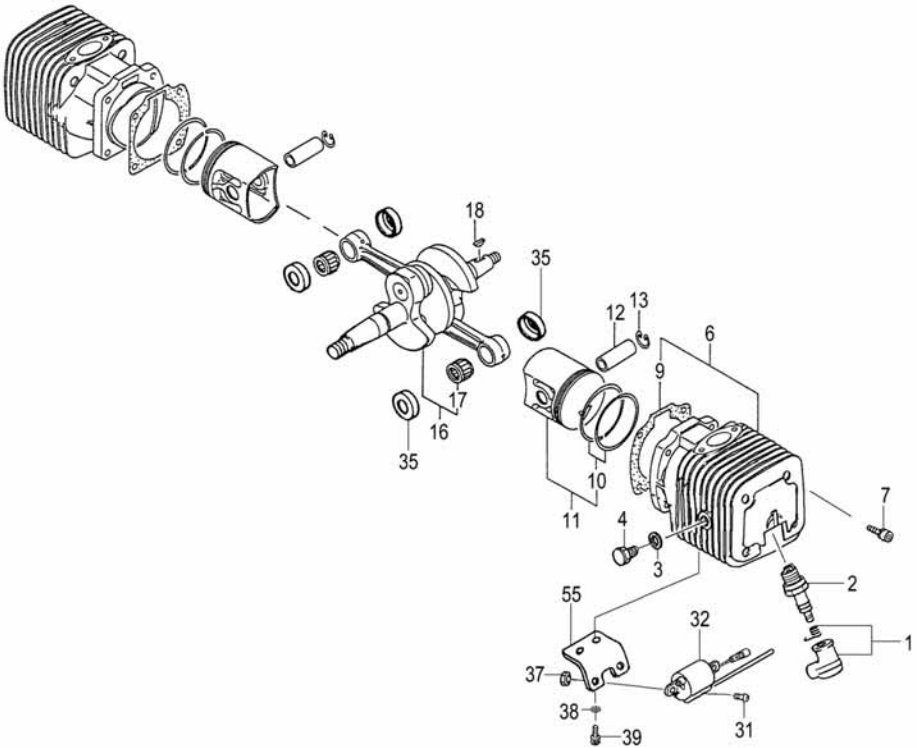

Key #	Part No.	Description
1.....	FJIG7500	Spark Plug Cap Assembly
2.....	FJIG7470	Spark Plug RCJ-6Y
3.....	FJIG4500	Decompression Valve Gasket
4.....	FJIG0112	Decompression Grommet
6.....	FJIG4440	Cylinder Set
7.....	FJIG8290	Hex Bolt 5x18/S
9.....	FJIG4350	Cylinder Packing
10.....	FJIG6660	Piston Ring Parker
11.....	FJIG6690	Piston Set
12.....	FJIG6480	Piston Pin 10x30
13.....	FJIG6540	Piston Pin C-Clip
16.....	FJIG4080	Crankshaft Complete
17.....	FJIG6180	Needle Bearing 2x8.8
18.....	FJIG7660	Woodruff Key 3x13x4.5
31.....	FJIG8215	Hex Bolt 4x15/PS
32.....	FJIG5340	Ignition Coil Complete
35.....	FJIG6570	Piston Pin Collar
37.....	FJIG8510	Hex Nut 4mm
38.....	FJIG8740	Washer 4mm
39.....	FJIG8200	Hex Bolt 4x12S
55.....	FJIG3540	Coil Holding Plate

CRANKCASE PARTS LIST

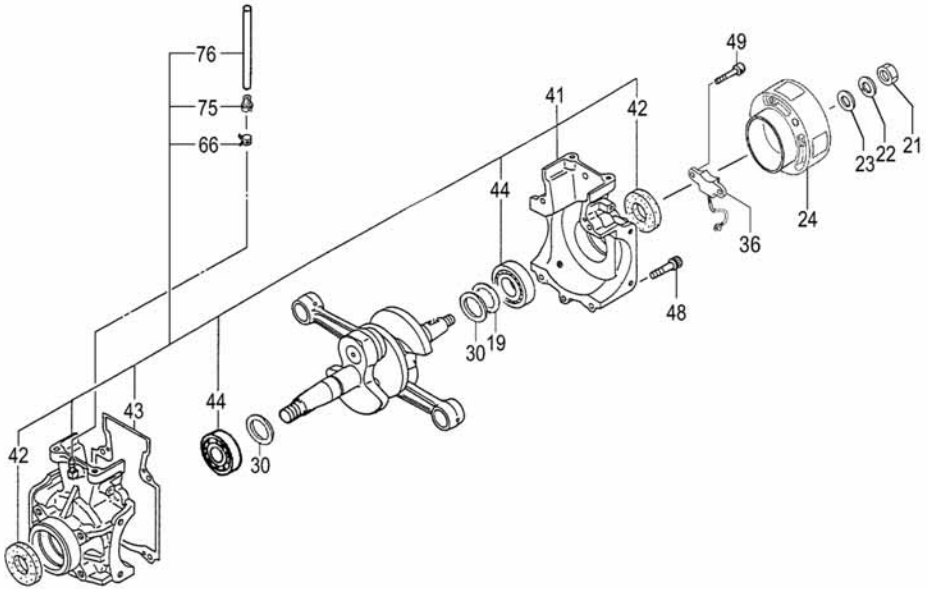

Key #	Part No.	Description
19A	FJIG7320	Shim 0.1mm
19B	FJIG7350	Shim 0.2mm
19C	FJIG7380	Shim 0.3mm
19D	FJIG7410	Shim 0.4mm
21	FJIG8520	Hex Nut 8mm
22	FJIG8685	Split Washer 8mm
23	FJIG8680	Small Washer 8mm
24	FJIG1006	Rotor Complete
30	FJIG4260	Crankshaft Washer 15.2x22
36	FJIG1003	Sensor Unit
41	FJIG3910	Crankcase Assembly
42	FJIG6300	Oil Seal
43	FJIG3990	Crankcase Gasket
44	FJIG3060	Ball Bearing 6201 A2C3
48	FJIG8300	Hex Bolt 5x20/S
49	FJIG8255	Hex Button Screw 5x12mm
66	FJIG3420	Clip 6.8mm
75	FJIG3031	Main Jet #50
76	FJIG4860	Fuel Pipe 4x7x30mm

MUFFLER AND ACCESSORIES PARTS LIST

Key #	Part No.	Description
a	FJIG1002	Control Unit Complete
b	FJIG8085	Propeller Fixing Bolt
c	FJIG8308	Hex Bolt 5x22/WS
d	FJIG8250	Hex Bolt 5x12S
e	FJIG9690	Box Wrench 10x19
f	FJIG4920	Hex Wrench 4mm
g	FJIG8775	Washer 10mm

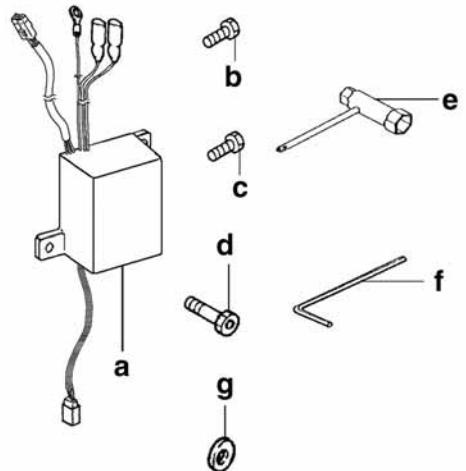

CARBURETOR PARTS LIST

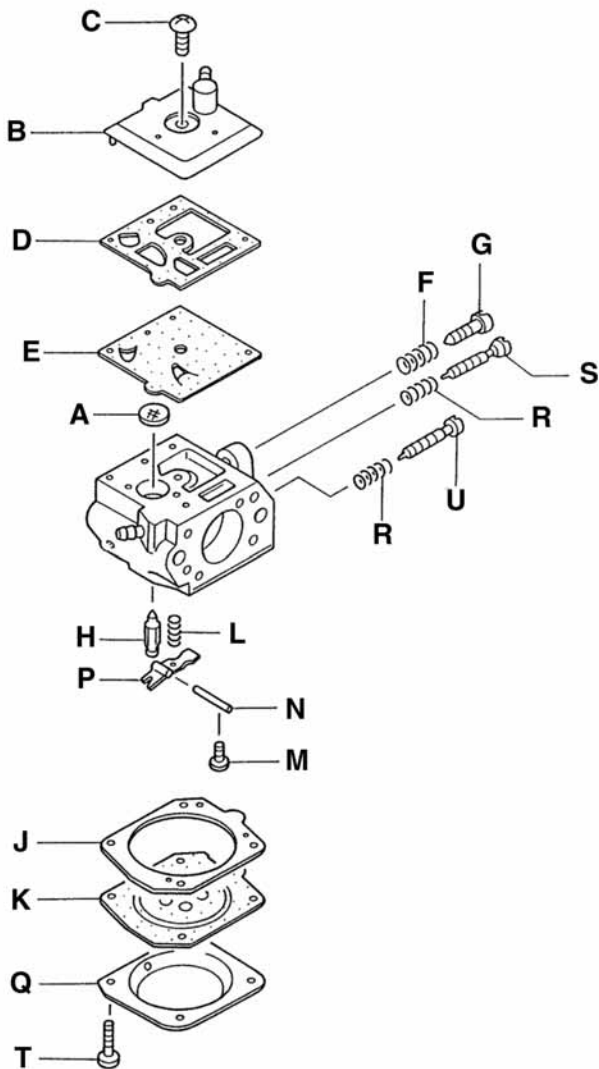

Key #	Part No.	Description	
A	FJIG5460	Inlet Screen	K..... FJIG5790 Metering Diaphragm Comp.
B	FJIG6990	Pump Body Complete	L..... FJIG7630 Valve Spring
C	FJIG7290	Set Screw	M..... FJIG5130 Hinge Pin Set Screw
D	FJIG7110	Pump Gasket	N..... FJIG5100 Hinge Pin
E	FJIG7050	Pump Diaphragm	P..... FJIG3750 Control Lever
F	FJIG5280	Idle Adjust Spring	Q..... FJIG4590 Diaphragm Cover
G	FJIG5220	Idle Adjust Screw	R..... FJIG3000 Adjust Spring
H	FJIG6240	Needle Valve	S..... FJIG5670 Low Adjust Screw
J	FJIG4650	Diaphragm Gasket	T..... FJIG7200 Set Screw
			U..... FJIG5010 High Adjust Screw

ENGINE PARTS LIST

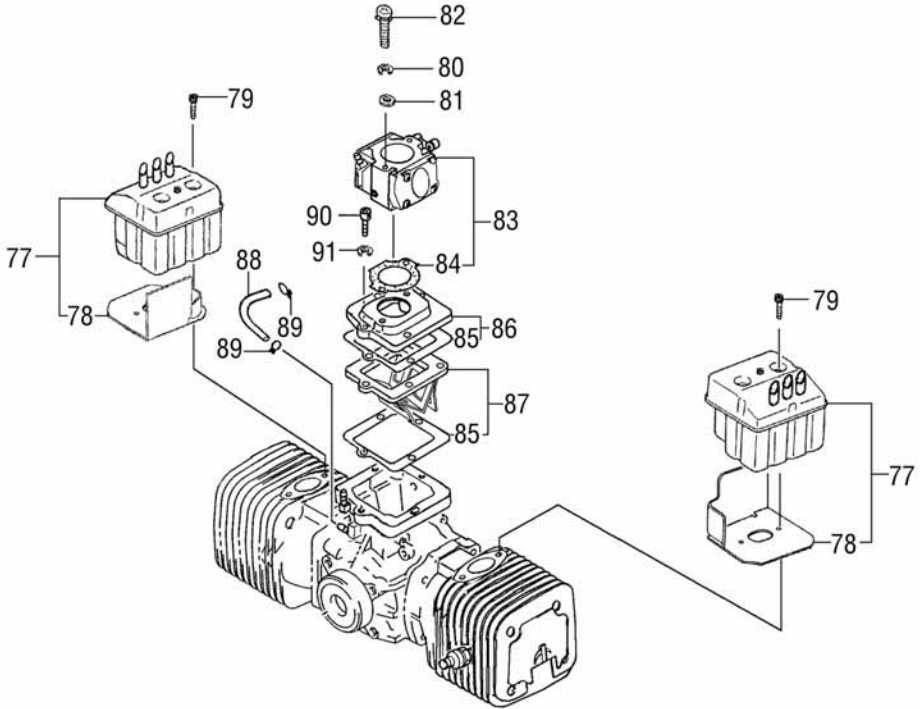

Key #	Part No.	Description
77.....	FJIG6090.....	Muffler Set
78.....	FJIG5940.....	Muffler Gasket
79.....	FJIG8280.....	Hex Bolt 5x16S
80.....	FJIG8605.....	Split Washer 5mm
81.....	FJIG8645.....	Small Washer 5mm
82.....	FJIG8340.....	Hex Bolt 5x50mm
83.....	FJIG3305.....	Carburetor Set HDA214
84.....	FJIG3150.....	Carburetor Gasket
85.....	FJIG5990.....	Insulator Gasket
86.....	FJIG5520.....	Carb. Insulator Gasket
87.....	FJIG7140.....	Reed Valve Set
88.....	FJIG4770.....	Fuel Pipe 3x5x85mm
89.....	FJIG3360.....	Clip 5.2mm
90.....	FJIG8320.....	Hex Bolt 5x25/S
91.....	FJIG8750.....	Washer 5mm

OPTIONAL ACCESSORIES

- FJIG1086..... Spring Starter
- FJIG1186..... Onboard Electric Starter
- FJIG4922..... Vibration Proofing Rubber (4 pieces/set)
- FJIG8062..... Spinner Bolt Tru-Turn Adapter
- FJIG8082..... Spinner Bolt
- FJIG9920..... Digital Tachometer
- FJIG7686..... Optional Prop Flange 50mm [2"] (Included)
- FJIG7687..... Optional Prop Flange 40mm [1-9/16"]
- FJIG7688..... Optional Prop Flange 60mm [2-3/8"]
- FJIG7689..... Optional Prop Flange 70mm [2-3/4"]

ENGINE MEASUREMENTS

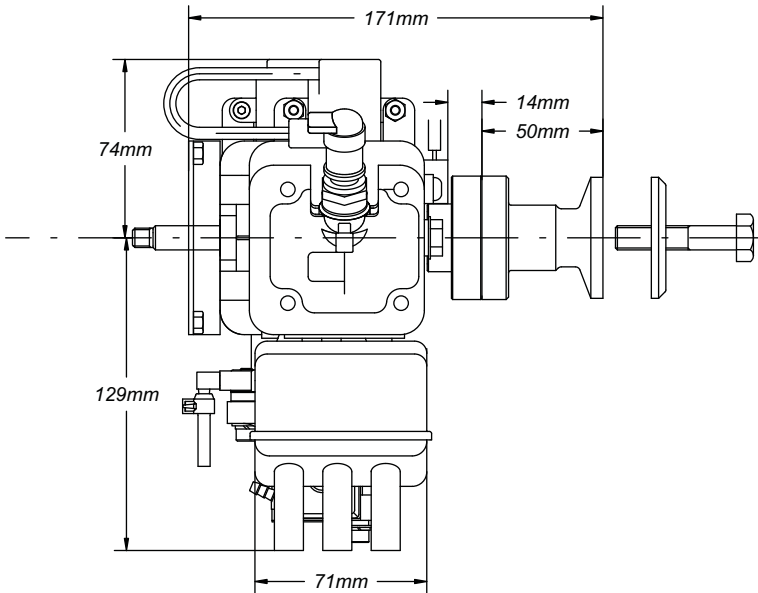
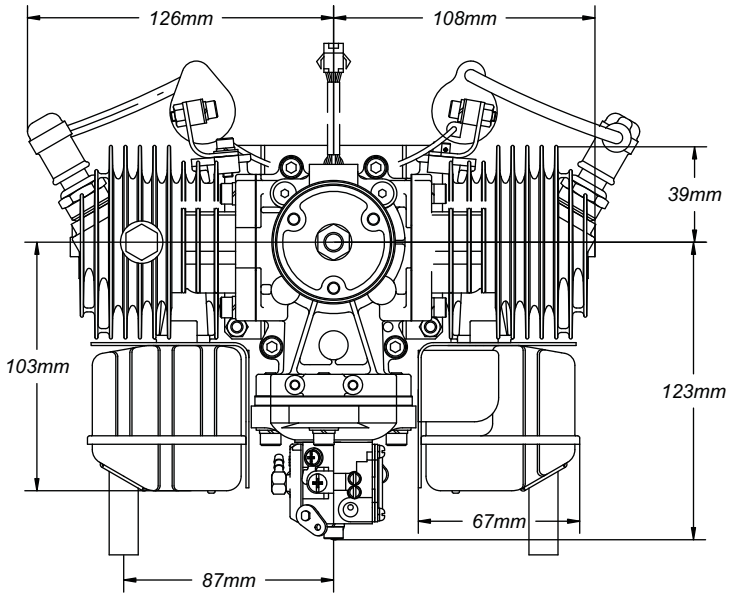

ENGINE MOUNT TEMPLATE FOR BT-86EI

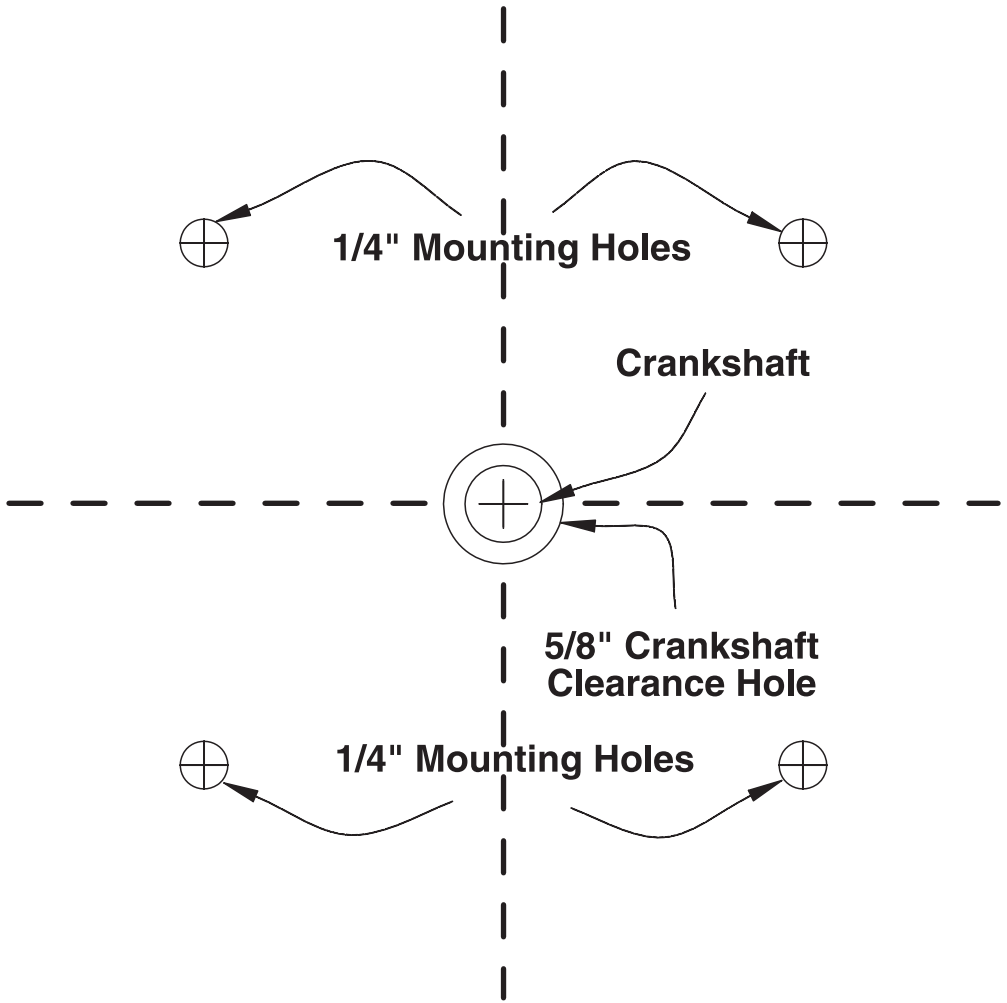

Place on front of firewall.