

**It's easy to keep up
with Duratrax!**



You can sign up to receive Duratrax E-Bulletins anytime at bestrc.com



Stress-Tech Parts are so durable, they're guaranteed! If any Stress-Tech part breaks during the first year you own your vehicle, Duratrax will send you a replacement part — FREE!



Compatible with all Futaba FHSS systems, including the 2PL, 3PL and 4PL.

CHEVY CAMARO ZL1



OFFICIAL LICENSED PRODUCT

99-3212-56659



Duratrax accessories. In it for the long haul.



Duratrax accessories are designed for just one thing: performing! Screw sets, tool sets and battery chargers are just the start. All are priced affordably, and all are built to last. Ding 'em, scratch 'em or dirty 'em, and they'll just keep coming back for more. Why? Like you, they're in it for the long haul.

Get the inside "scoop" at duratrax.com/109e



Accessories

Pit-Tech™ Deluxe Car Stands



Handy workstation features a rotating upper plate with molded rubber insert grips. Base includes an extra-large parts tray.

- DTXC2370 Blue
- DTXC2371 Orange
- DTXC2372 Purple
- DTXC2373 Green

Pit Mats



The 5 x 5 in (63.5 x 63.5 mm) size is ideal for small parts and hardware. The 29 x 19 in (736.6 x 482.6 mm) has room for your vehicle, heli or small plane, too. Both are made of durable, solvent- and fuel-resistant rubber.

- DTXP2045 5 x 5 in Pit Mat (63.5 x 63.5 mm)
- DTXP2050 29 x 19 Pit Mat (736.6 x 482.6 mm)

FCC REQUIREMENT This device complies with part 15 of the FCC rules. Operation is subject to the following two conditions.



- (1) This device may not cause harmful interference.
- (2) This device must accept any interference received, including interference that may cause undesired operation.

NOTE: THE MANUFACTURER IS NOT RESPONSIBLE FOR ANY RADIO OR TV INTERFERENCE CAUSED BY UNAUTHORIZED MODIFICATIONS TO THIS EQUIPMENT. SUCH MODIFICATIONS COULD VOID THE USER'S AUTHORITY TO OPERATE THE EQUIPMENT.

CE COMPLIANCE INFORMATION FOR THE EUROPEAN UNION

Instructions for Disposal of Waste Equipment by Private Users in the European Union: This symbol on the product or its packaging indicates this product must not be disposed of with other household waste. Instead, it is the user's responsibility to dispose of their waste equipment by handing it over to a designated collection point for the recycling of waste electrical and electronic equipment. The separate collection and recycling of your waste equipment at the time of disposal will help to conserve natural resources and ensure that it is recycled in a manner that protects human health and the environment. For more information about where you can drop off your waste equipment for recycling, please contact your local city office, your household waste disposal service or location where you purchased the product.

Declaration of Conformity:

Product: Duratrax T240F 2.4GHz 2-Channel Tx and R240 3-Channel Rx
Item number: T240F, Equipment class: 2

The objects of the declaration described here are in conformity with the requirements of the specifications listed below, following the provisions of the European 2006/95/EC Low Voltage Directive:

IEC 60950-1:2005(2nd Edition) + Am1:2009/EN 60950-1:2006 + A11:2009 + A1:2010 + A12:2011

The objects of the declaration described here are in conformity with the requirements of the specifications listed below, following the provisions of the European R&TTE directive 1995/5/EC:

Radio: ETSI EN 300 328 V1.7.1 (2006-10)

EMC: ETSI EN 301 489-1 V1.8.1 (2008-04, Clause 9.2 and 9.3)
ETSI EN 301 489-17 V2.1.1 (2009-05)

The associated regulatory agencies of the following countries recognize the noted certifications to this product as authorized for sale and use.

UK	DE	DK	BG	SE	FI	GR
EE	LV	LT	PL	CZ	SK	HU
RO	SI	AT	IT	ES	PT	IE
NL	LU	MT	CY			

CE 0682



Included radio system not fully compliant with French regulations.

Duratrax
c/o Hobbico, Inc.
2904 Research Road
Champaign, IL USA 61826



TABLE OF CONTENTS



SAFETY PRECAUTIONS AND WARRANTY 5



TUNING GUIDE..... 10



GETTING READY TO DRIVE..... 6



ASSEMBLY GUIDE..... 13



BREAK-IN PROCEDURE 8

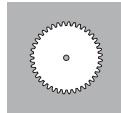

REPLACEMENT PARTS 27

CONTENTS

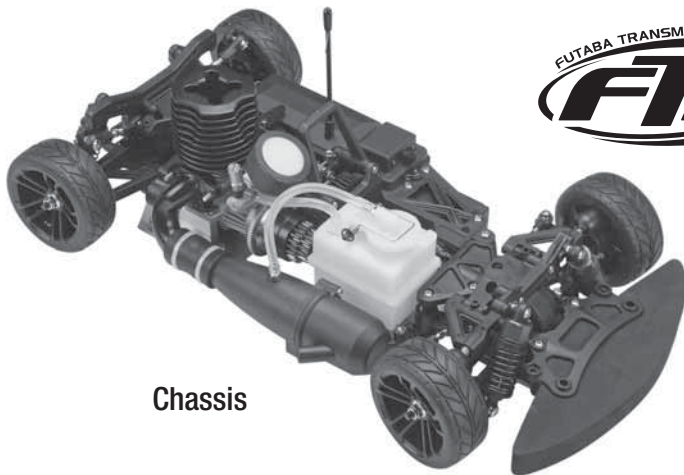

Chassis



Duratrax T240F
2.4 GHz Transmitter



Bind Tool



Engine Stop Tool



Shock Clips



Super Start



Rear Hinge Pin Mount



Antenna
Tube

REQUIRES



“AA” (x8)
7.2V 6-Cell Battery Pack & Charger
(DTPX4615)



Glow Starter & Charger
(DTPX3000)



Air Filter Oil
(DTXC2465)



Fuel Bottle
DTPX0150



Fuel
(ODOP4520)



SAFETY PRECAUTIONS

To prevent injury and damage to property, follow these safety precautions when operating any radio control vehicle.

- ④ Keep all spectators a safe distance away from the vehicle.
- ④ ALWAYS turn the transmitter on before the receiver.
- ④ NEVER touch any part of the engine or exhaust as they can become very hot.
- ④ ALWAYS keep model engine fuel out of the reach of children and follow precautions on the container.

- ④ NEVER smoke and avoid ignition sources when using model engine fuel. Model engine fuel is poisonous and flammable. Keep away from open flame.
- ④ NEVER run your model indoors. Fuel powered vehicles create harmful fumes.
- ④ Use a mat or towel when working on your model to protect your work surface.
- ④ Do NOT run your radio control vehicle in cold weather as plastic parts may become brittle.

SPECIFICATIONS & DESCRIPTION CHANGES

ALL information found in this manual is subject to change without notice. Visit Duratrax.com for the latest updates and information on your model. Duratrax maintains no responsibility for inadvertent errors in this manual.

LIMITED WARRANTY

Duratrax guarantees this kit to be free from defects in materials or workmanship for 90 days (3 years for the engine) after the date of purchase. Duratrax will repair or replace at no charge any incorrectly made part.

Your receipt or invoice at time of purchase is your proof of purchase and is required for Duratrax to honor any warranty. Duratrax

reserves the right to change or modify this warranty without notice.

For warranty repairs, contact or send to:

Hobby Services
3002 N. Apollo Drive Suite 1
Champaign, IL 61822
ATTN: Service Department
Phone: (217) 398-0007

9:00 am – 5:00 pm Central Time M-F
E-mail: hobbyservices@hobbico.com
www.hobbyservices.com

IF the buyer is not prepared to accept the liability associated with the use of this product, buyer is advised to return kit immediately in new and unused condition to the place of purchase.

STRESS-TECH PARTS GUARANTEE

Stress-Tech parts are guaranteed for 12 months from the date of purchase. Check the parts list for items covered under the Stress-Tech guarantee. Should a Stress-Tech part break during the first 12 months after purchase, return the part to Hobby Services and we will send you a FREE replacement.

To receive your FREE replacement Stress-Tech part, include the following and return to Hobby Services at the address above:

1. Broken part
2. Part number and description of the broken part
3. COPY of your dated purchase invoice or receipt
4. Name, phone number and shipping address



REPAIR SERVICE

Hobby Services offers repair services after the limited warranty or 12 month Stress-Tech parts replacement for a minimal charge.

Follow these instructions for your repair request:

1. Most circumstances require the return of the ENTIRE vehicle. STRESS-TECH requires ONLY the broken part to be returned following the instructions above.
2. Turn off the transmitter and remove the batteries.
3. Empty fuel tank on nitro vehicles.
4. Include written instructions listing ALL items being returned with a THOROUGH description of the problem, service needed and your DAYTIME phone number. IF you expect the repair to be covered under the limited warranty, include copy of receipt or invoice with date of purchase.

5. Send to Hobby Services at the address above. When shipping your item(s) to us, we recommend that you insure them and use a company that offers tracking service (such as UPS or Federal Express).

We will carefully inspect your item and notify you of our findings. You will be advised of your options for return, repair, or replacement. Please note that items sent back unrepaired will carry a return shipping and service charge.

Hobby Services accepts Visa®, MasterCard®, or you can send a check. We can return the item C.O.D., but additional charges will apply.



GETTING READY TO DRIVE

Follow these steps to get the radio, super start, and Camaro ready for use.

1. CHARGE THE SUPER START BATTERY*

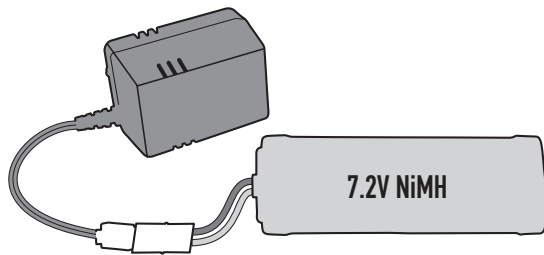

*Charger and battery not included.

2. PREPARE THE SUPER START

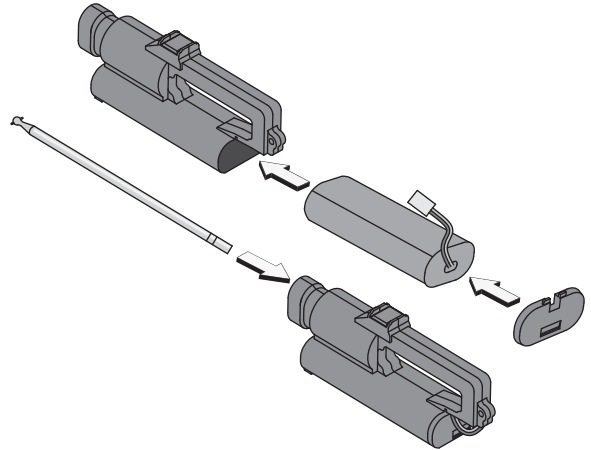

3. INSTALL TRANSMITTER BATTERIES

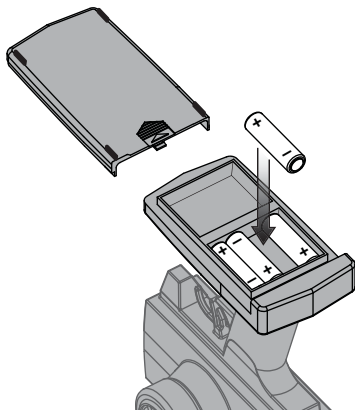

4. INSTALL RECEIVER BATTERIES

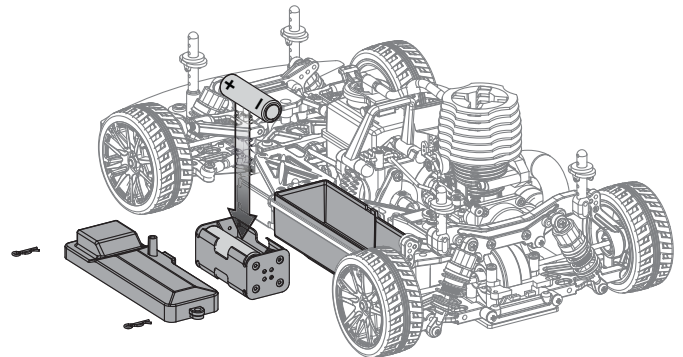

5. INSTALL ANTENNA TUBE

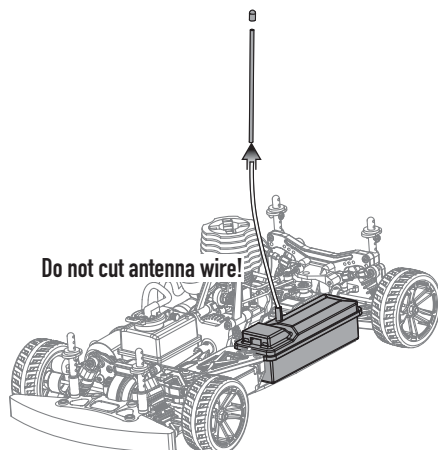

6. OIL AIR FILTER



- Apply air filter oil (DTXC2465) onto the foam element, squeezing the element until it is completely coated with the oil.
- TIP! Placing the element in a plastic bag will help keep your hands clean.
- Remove any excess oil with a paper towel.



7. POWER UP TRANSMITTER

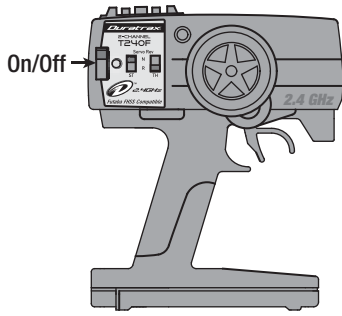

Check radio operation before each run!

If you ever need to rebind the receiver, turn on the system and press the bind button on the receiver using the included binding tool until the L.E.D. turns solid green.

8. CHECK THROTTLE

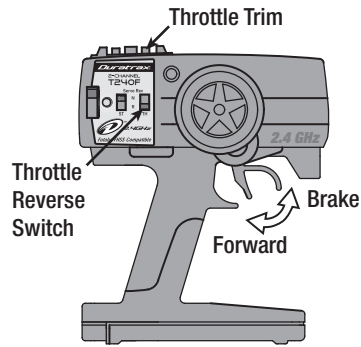

Check radio operation before each run!

9. CHECK STEERING

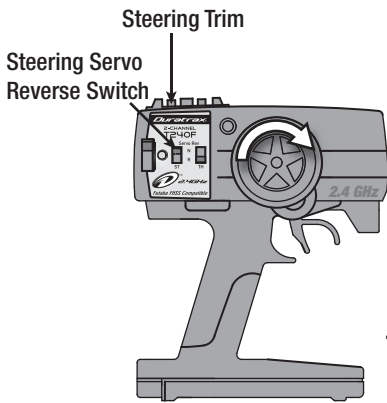

Check radio operation before each run!

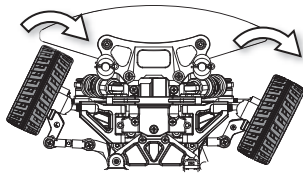

10. FUEL THE CAR

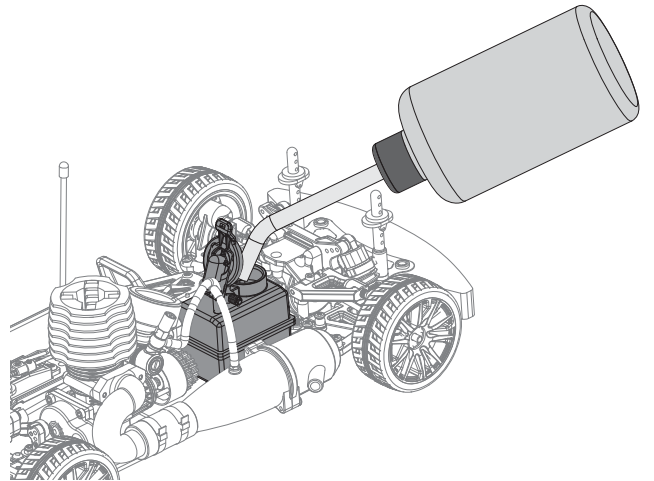

11. ATTACH GLOW STARTER

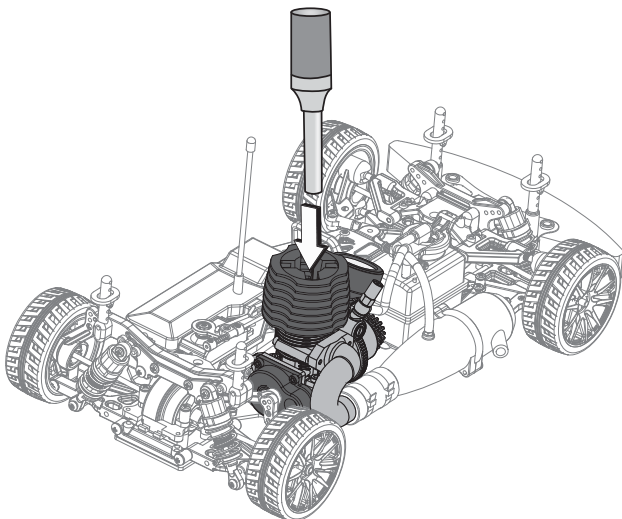

12. START THE ENGINE

See page 8 for starting and engine break-in details.

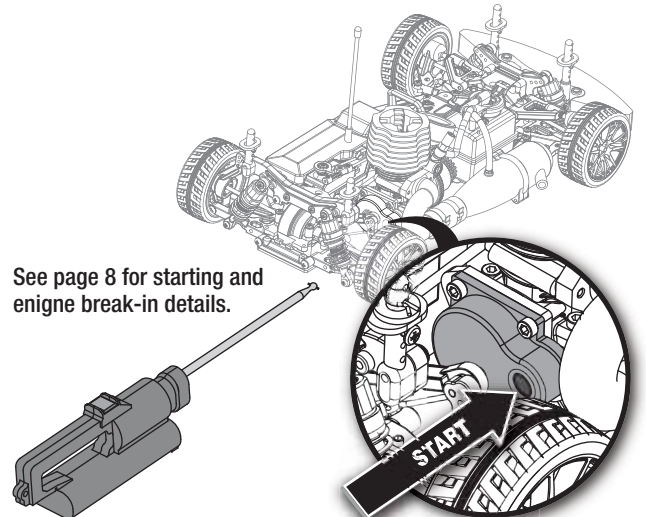



BREAK-IN PROCEDURE

When starting, hold the throttle slightly open. If the engine is difficult to turn over, loosen glow plug 1/2-turn before starting engine (this allows some compression to escape while allowing the engine to start). Once engine starts tighten the glow plug.

IMPORTANT! FLOODED ENGINE: If the Super Start still is having problems turning the engine over, it is flooded (too much fuel inside the engine).

1. Remove glow plug and turn vehicle upside down, pointing away from you.
2. Run Super Start for 5-6 seconds (clearing engine of fuel).
3. Replace glow plug.
4. Repeat starting engine steps.

Initial engine break in will be accomplished with the first 5 tanks of fuel. (Full break-in may take up to 15 tanks.)

1. During break-in, run with the body off to keep the engine cool.
2. Keep air filter on at all times.
3. Run on smooth, hard surface.
4. Make sure you have extra glow plugs. Break-in puts stress on the glow plug and it may need to be replaced.

TANK 1

Run very rich allowing fuel to carry as much oil as possible to lubricate internal engine parts.

1. High Speed Needle Valve: Check this setting before running. Close the high speed needle by rotating it clockwise until you just feel resistance, then open to 3 full turns out (counterclockwise).
2. Run at medium speeds, slowly accelerating and decelerating. **NOTE:** It is normal for the two speed NOT to shift during this tank.
3. If engine does not stay running consistently, increase idle speed by turning the idle stop screw clockwise.
4. DO NOT allow the tank to run out of fuel during break-in.
5. Stop engine by placing the engine tool into the exhaust outlet. Allow it to cool approximately 10 – 15 minutes.

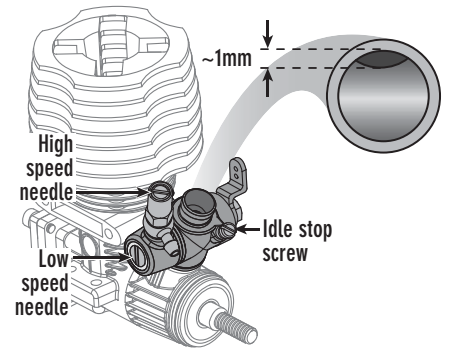

TANKS 2-4

1. For each additional tank, lean high speed needle 1/12 turn from the previous tank's setting.
2. Stop engine, allowing it to cool approximately 10 – 15 minutes, between each tank.

TANK 5

1. Lean high speed needle an additional 1/12 turn from Tank 4 setting.
2. The engine should now be very close to final tune and be broken in and ready to be performance tuned.

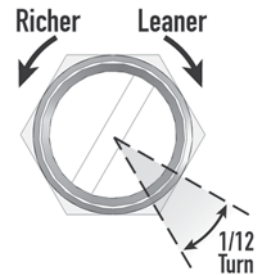

TUNING TIPS (Adjust only after the engine is fully broken in.)

IMPORTANT! Always run the engine for 1-2 minutes to warm up temperature before tuning! Only use "small" adjustments (1/12 turn at a time) and test the results.

- **High Speed Needle:** Controls the fuel/air mixture at high throttle settings. A properly tuned engine will accelerate smoothly and exhaust a small amount of smoke. The goal is to tune the engine to make good power without overheating. Engine temperature should stay around 250° F (132° C) using a temperature gauge (Duratrax Flashpoint™, DTXP3100). **Note:** This temperature is a "guideline" only. Your engine may run slightly warmer or cooler depending on conditions; fuel, track, and how you drive.

On hot days, additional cooling may be needed. Cut a 60mm hole in the rear window to allow more airflow through the body.

- **Low Speed Needle:** Controls fuel mixture at low throttle settings (idle). To check this setting, keep the throttle at idle and pinch the fuel line close to the carburetor. A correct setting will increase the engine speed after 2-3 seconds and then lose speed.
 - If it slows too quickly, the mixture is too lean. Open the low speed needle (counterclockwise).
 - If it takes longer than 4 seconds to slow down, the mixture is too rich. Close the low speed needle (clockwise).
- **Idle Stop Screw:** Adjust this screw to set the idle speed so the wheels do not rotate when you lift the vehicle off of the ground. When looking into the carburetor, the barrel should be about 1mm from fully closed.

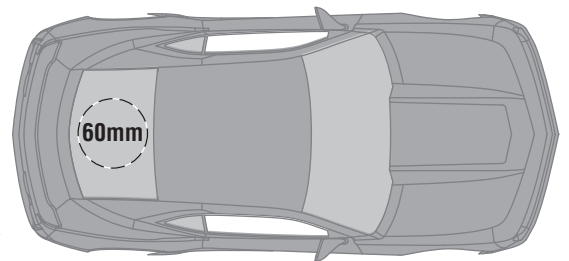

CARE AND MAINTENANCE

1. Keep engine clean and free of dirt.
2. Do not over lean engine.
3. Run all of the fuel out of the engine before storing.
4. Use after run oil and work it into the engine by turning the flywheel before storing.
5. Do not use a fuel with a nitromethane content over 30%.

Engine Tools & Accessories

Engine Tuning Screwdriver



Standard slot-head screwdriver has a 120 mm hardened steel shaft with 3.2 mm wide magnetized tip and rubberized, hexagonal handle.
DTXR0185

TrakPower™ Speed Wash Nitro Cleaner

Applies with or without water and is safe for titanium, aluminum, fiberglass, clear coat, stainless steel, chrome, rubber, plastic, vinyl and leather. 32 fl oz (946 mL).
TKPC8001



Air Filter Oil

Treats foam air filter elements to increase filtering capacity and extend engine life. Handy 1.75 fl oz (51.7 mL) bottle fits easily into a tool box or tote.
DTXC2465



Rapid Heat™ Glo-Starter

Twist-on for a secure connection to heat your glow plug. Twist the other way for easy removal. Includes NiCd and AC charger.
DTXP3000



Glow Plugs

Hand-assembled with heat resistant coils. Carbon Speed is medium-hot for informal racing and sport use. Gold Racing Plug is for higher nitro fuels and competitive driving.

DTXG3003 Carbon Speed Plug
DTXG3005 Gold Racing Plug



Deluxe Car Wrenches

Deluxe includes 6 socket head sizes and stores up to 4 glow plugs. Ultimate adds a slotted/Phillips screwdriver bit and 19 mm socket for 1/8 car wheel nuts.

DTXR1170 Deluxe Car Wrench
DTXR1175 Ultimate Car Wrench



Kwik-Pit™ Fuel Bottles

A squeeze on the clear plastic body lets you control fuel flow. The 5 in (63.5 mm) long aluminum spout features a curved tip for no-spill refills and a tip cap to prevent leaks. For glow fuel only.

DTXP0125 250 cc (8.5 fl oz) Fuel Bottle
DTXP0150 500 cc (17.0 fl oz) Fuel Bottle



O'Donnell Racing Fuel®

Speed Blend improves fuel economy and pushes engine performance to the absolute peak. Race Blend simplifies tuning and reduces engine heat and internal wear.

ODOP3320 20% Racing Fuel Quart
ODOP3325 25% Racing Fuel Quart
ODOP3330 30% Racing Fuel Quart
ODOP4520 20% Speed Blend Quart
ODOP4525 25% Speed Blend Quart
ODOP4530 30% Speed Blend Quart



FlashPoint™ Infrared Temperature Gauge

Just point and press for fast, accurate, no-touch temperature readings of engines, motors, batteries and more. Works in seconds and turns off automatically after 15 seconds of inactivity.
DTXP3100





TUNING GUIDE

As a starting point, make sure your car has equal lengths on shocks, camber links and steering rods on both sides (left and right). Front and rear do not need to be equal.

CASTER

Angle of the front knuckles in relation to the ground when viewed from the side.

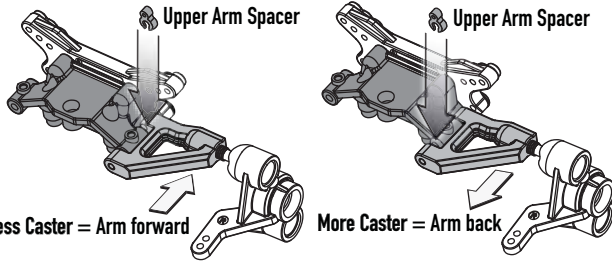

- Decreases on power steering when entering a corner.
- Turns feel smoother.
- Increased off power steering when entering a corner.
- Straight line stability.
- Vehicle more responsive.

ACKERMAN

The difference in turning angle between the inside wheel and outside wheel in a turn.

More Ackerman = Inside wheel turns increasing more than the outside wheel. Move steering rod back on the knuckle or forward on bellcranks.

More aggressive steering, vehicle turns more abruptly.

Less Ackerman = Inside wheel turns more equal to the outside wheel. Move steering rod forward on the knuckle or back on the bellcranks. Less aggressive steering, smoother cornering.

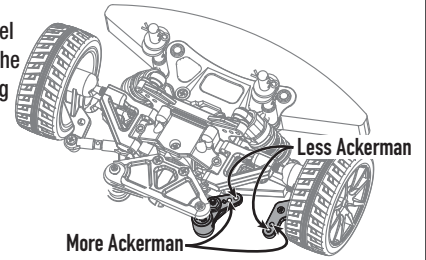

CAMBER

Angle of the tire and wheel in relation to the ground when viewed from the front.

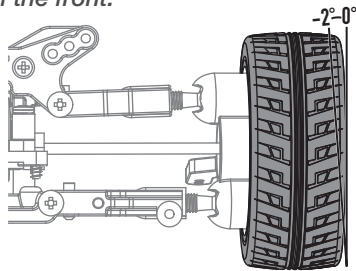

- Negative Camber** = Tire and wheel lean inward (Typically 0° to -2°)
 - Improved traction while cornering.
 - Adds overall stability.
- Positive Camber** = Tire and wheel lean outward (This is NOT recommended)

ROLL CENTER

Point at which the vehicle rolls laterally when cornering.

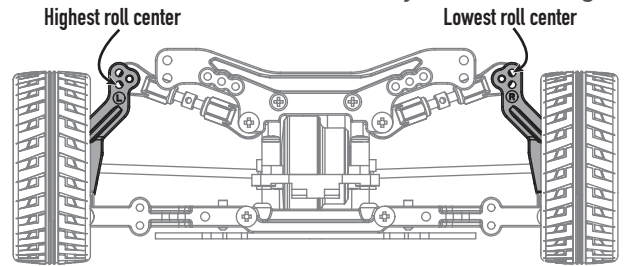

- Raising Roll Center:** Raise rear camber rod mounting location on the hub. Increases rear on power traction and decreases rear traction during braking.
- Lowering Roll Center:** Lower rear camber rod mounting location on the hub. Decreases rear traction on power, reduces corner entry steering and increases corner exit steering.

FRONT TOE-IN AND TOE-OUT

Direction the wheels point in relationship with each other, when viewed from above.

Toe-In: Fronts of the wheels point toward each other. (Typically 0 to -2°)

- Increased stability when accelerating. Decreased steering when entering a corner.

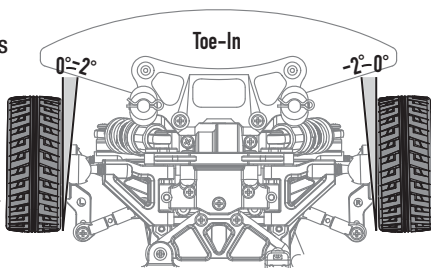

Toe-Out: Fronts of the wheels point away from each other.

- Decreased stability when accelerating and increased steering when entering a corner.

2-SPEED SHIFT POINT

Proper shift point helps keeps the engine within its optimum RPM range.

THE ENGINE MUST BE COMPLETELY BROKEN IN AND UP TO OPERATING TEMPERATURE BEFORE MAKING SHIFT POINT CHANGES.

IF YOU NEED TO MAKE A CHANGE, STOP THE ENGINE!

- Shifts too soon** (Vehicle will lose acceleration): Turn the screw in, making the vehicle shift later and engine rev higher before shifting.
- Shifts too late** (Vehicle will not hit top speed): Turn the screw out, making the vehicle shift sooner and engine rev less before shifting.

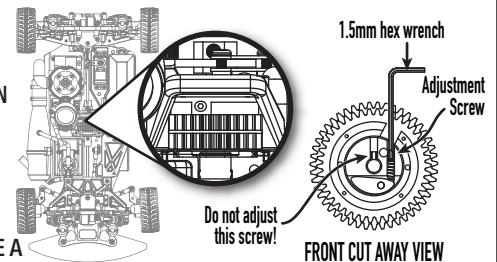



SHOCK ADJUSTMENTS

Top Shock Outer Positions:

- Decreases steering
- Quicker suspension reaction

Top Shock Inner Positions:

- More aggressive steering
- Smoother over bumps

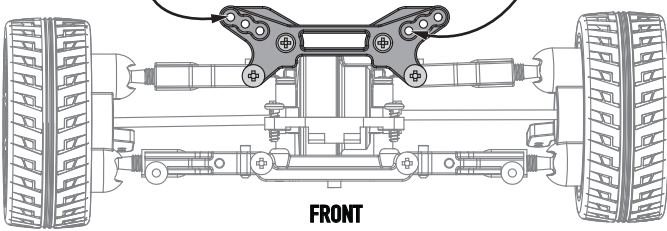

FRONT

Top Shock Outer Positions:

- Increase steering
- Quicker suspension reaction

Top Shock Inner Positions:

- More traction in corners
- Smoother over bumps

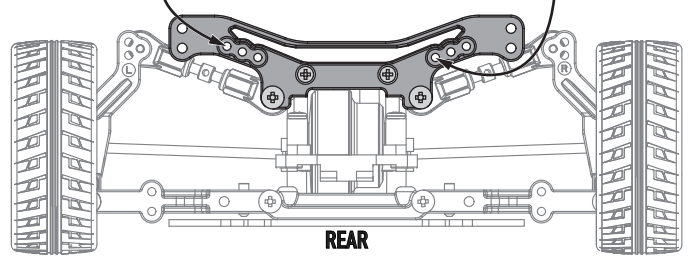

REAR

DROOP

Distance the chassis can lift from ride height before the wheels come off the ground.

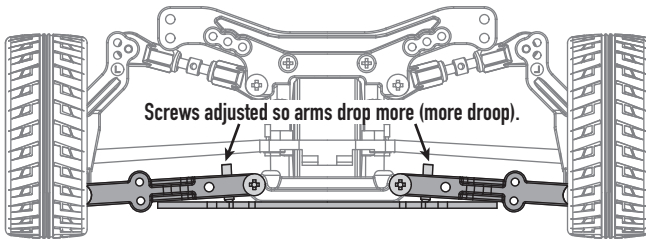

Screws adjusted so arms drop more (more droop).

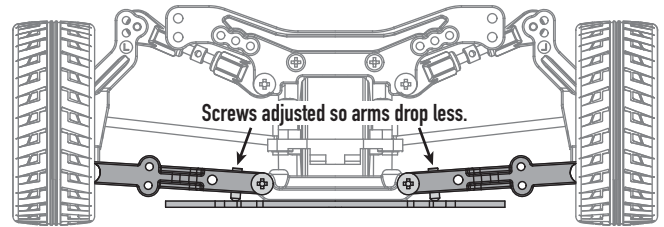

Screws adjusted so arms drop less.

More Front Droop: Increases chassis up travel when on throttle and decreases high speed steering, making vehicle turn smoother. Good for low traction and bumpy surfaces.

Less Front Droop: Decreases chassis up travel when off throttle and under braking, making steering more aggressive. Good for high speed smooth surfaces.

More Rear Droop: Increases chassis up travel when off throttle and under braking. Increases steering in low speed corners and under braking.

Less Rear Droop: Decreases steering in low speed corners, making the vehicle turn smoother.

RIDE HEIGHT

Distance the chassis sits from the ground and how much weight is transferred when the vehicle changes speed and direction.

More spacers on the front shock.

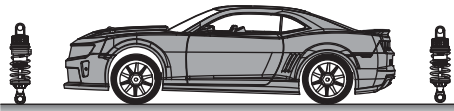

Same number of spacers front and rear.

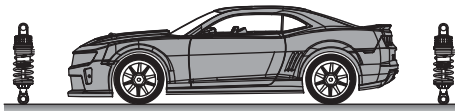

More spacers on the rear shock.

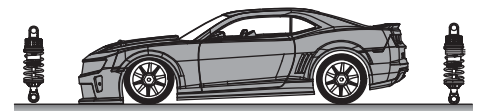

Lower Rear: More rear traction but reduces steering.

Lower Front: Increases steering but can cause rear end to break loose.

CHASSIS MAINTENANCE TIPS

Check before every run:

1. All hardware to be sure everything is tight.
2. Transmitter batteries.
3. Moving parts are free from binding.
4. Parts are not broken or damaged.

5. Wires are properly connected.

6. Remove dirt or debris from chassis and moving parts.

7. Bearings should roll smoothly.

8. Shocks should operate smoothly. Check for leakage and refill as needed.

9. Gear mesh between the spur and pinion gears.

Tools

Engine Tuning Tool



Two tools for the price of one – a steel shank screwdriver with a knurled, anodized aluminum handle and a piston locking tool! Includes storage space for one spare glow plug.
DTXR0187

Ultimate Flywheel Wrench



Slotted to fit 2-, 3- or 4-pin flywheels, this aluminum wrench safely holds the flywheel while you tighten or loosen clutch nuts — without stressing internal engine components.
DTXR1105

12-Tip Multi-Driver



The aluminum handles holds six shanks with 12 adjustable-length tips, suited for many different driving needs. Rotate the end cap to select the tip you need. Tips included: 1.5 mm and 2 mm slotted; 0 and 00 Phillips; and 1.5 mm, 2.0 mm, 2.5 mm, 3.0 mm, .050", 1/16", 5/64", and 3/32".
DTXR1165

Ultimate Tool Sets



Tools in these convenient sets have knurled, blue-anodized aluminum handles; hardened steel shafts; precision-ground tips; and tip sizes engraved onto the handles.

- DTXR0179 3-Piece Ultimate Slotted Screwdriver Set (2, 3 and 4 mm)
- DTXR0183 3-Piece Ultimate Phillips Screwdriver Set (2, 3 and 4 mm)
- DTXR0292 4-Piece Ultimate Hex Driver Set (1.5, 2, 2.5 and 3 mm)
- DTXR0297 4-Piece Ultimate Ball Driver Set (1.5, 2, 2.5 and 3 mm)
- DTXR0392 4-Piece Ultimate Hex Driver Set (.050, 1/16, 5/64 and 3/32 in)

Crankshaft Locking Tool

This handy tool threads into your engine's glow plug socket, locking the piston and crankshaft to prevent them from turning while you perform maintenance.
DTXR1100



Ultimate Body Reamer



The extra-sharp point starts holes precisely where you want them, while the knurled aluminum handle provides a secure grip. A snap-on cap protects the tip when not in use.
DTXR1157

6" Long Nose Pliers

Forged from chrome alloy steel, these pliers feature rubberized handles and serrated jaws for easy wire bending, cutting and stripping.
DTXR0300



Tool Set and Pouch



Set includes 4 each of metric and SAE hex drivers, 3 each of slotted and Phillips screwdrivers, plus an Ultimate Body Reamer — all organized in a zippered, 15-pocket tool pouch (pouch also available separately).

- DTXR0400 15-Piece Ultimate Tool Set w/Pouch
- DTXR0401 15-Pocket Ultimate Tool Pouch Only

ASSEMBLY GUIDE

MAINTENANCE AND REPAIRS

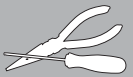

1

D (x1)
2x10mm

JJ (x8)
2x8mm

TT (x2)
2.5mm

123 (x4)
10x15mm

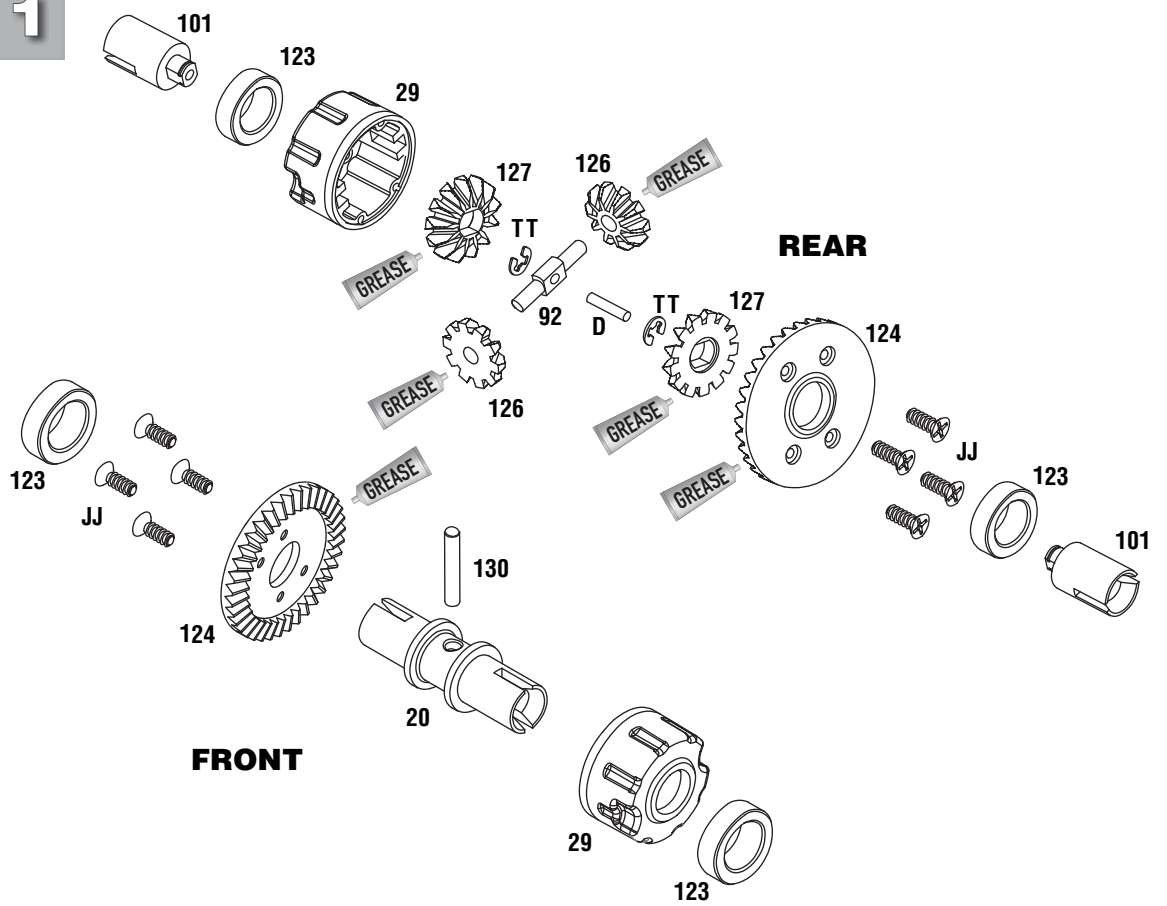

P (x2)
3x8mm

DD (x2)
4x3mm

LL (x8)
3x18mm

TT (x2)
2.5mm

119 (x4)
5x11mm

2

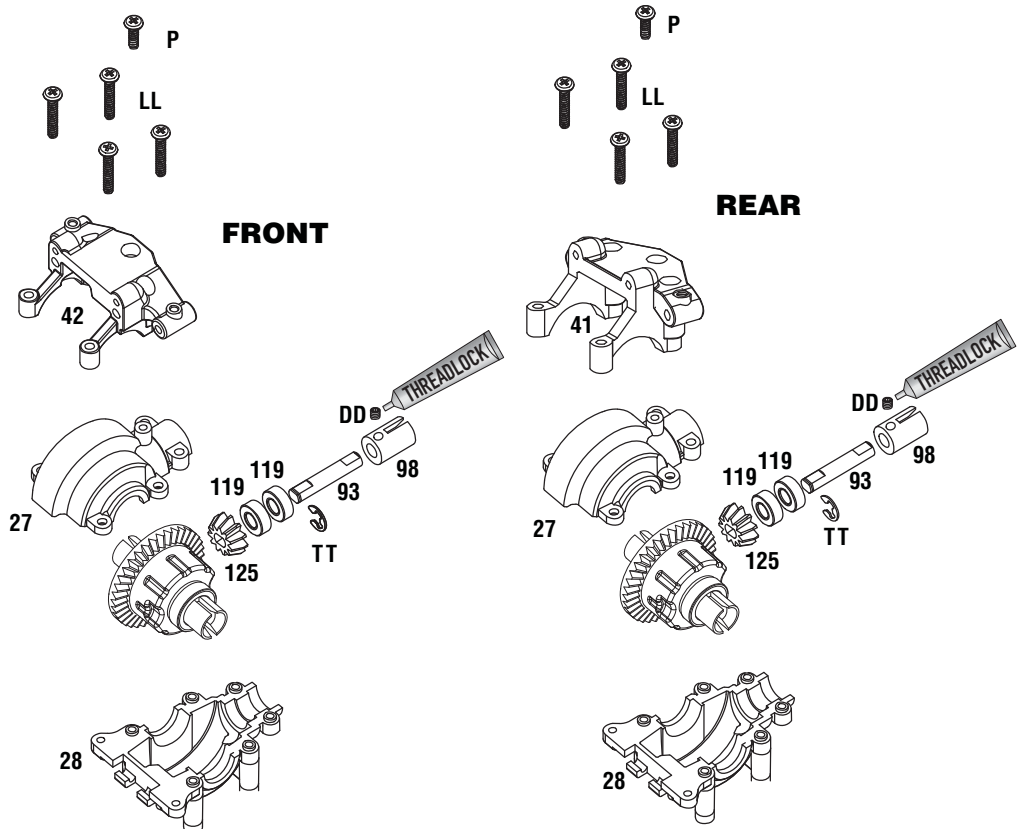

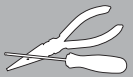

3

C (x2)
2x11mm

MM (x4)
1.6x8mm

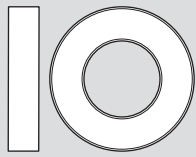

122 (x1)
10x19mm

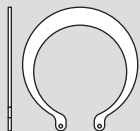

WW (x1)
13mm

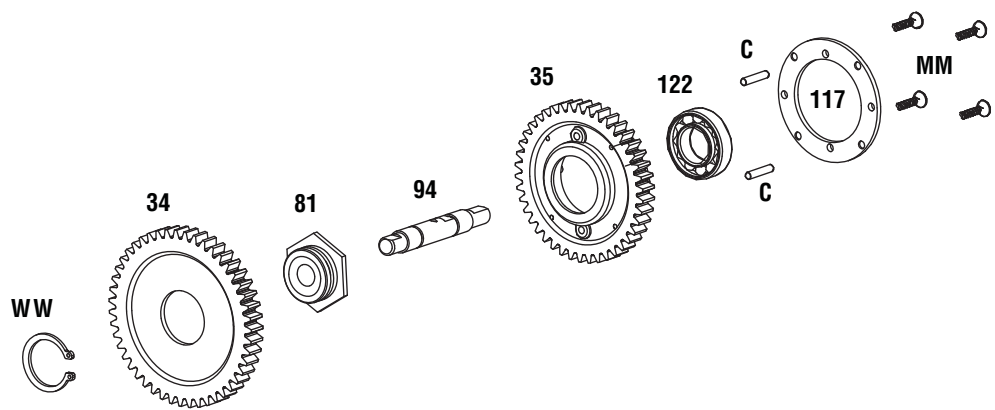

4



121 (x2)
6x12mm

T (x2)
3x28mm

CC (x1)
4x4mm

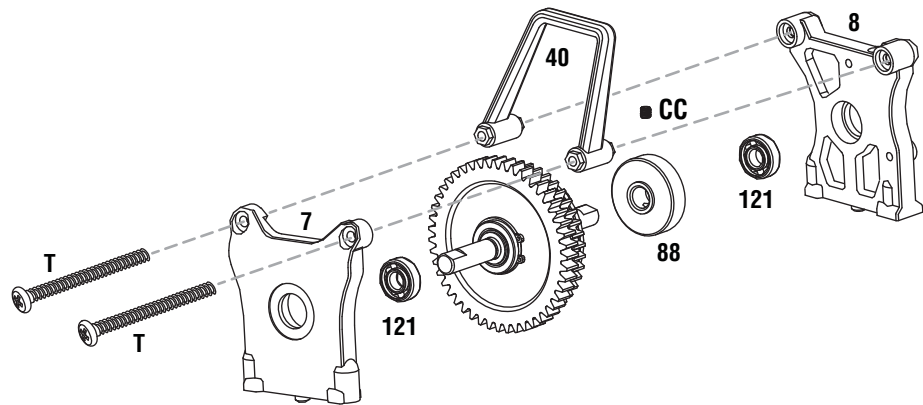

5

W (x2)
3x12mm

AA (x1)
3x3mm

CC (x1)
4x4mm

DD (x1)
4x3mm

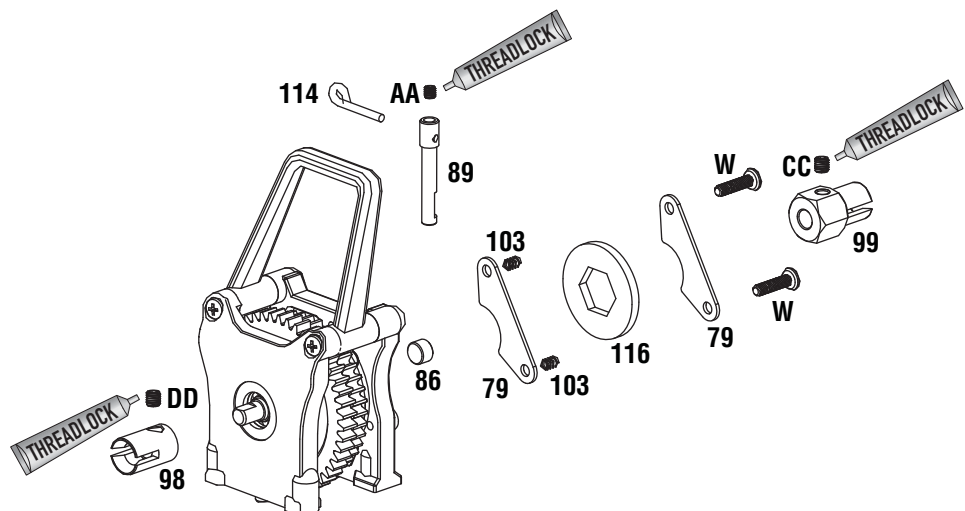

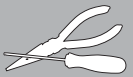

6



L (x4)
3x12mm



Q (x2)
3x10mm



HH (x8)
3x10mm

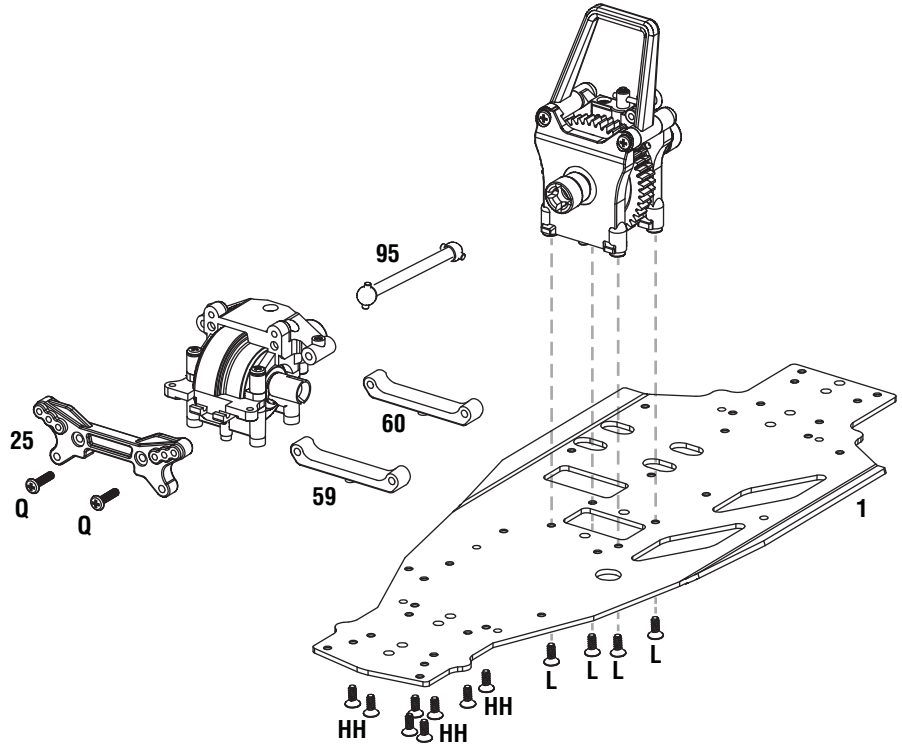

7



119 (x2)
5x11mm

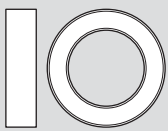

123 (x2)
10x15mm

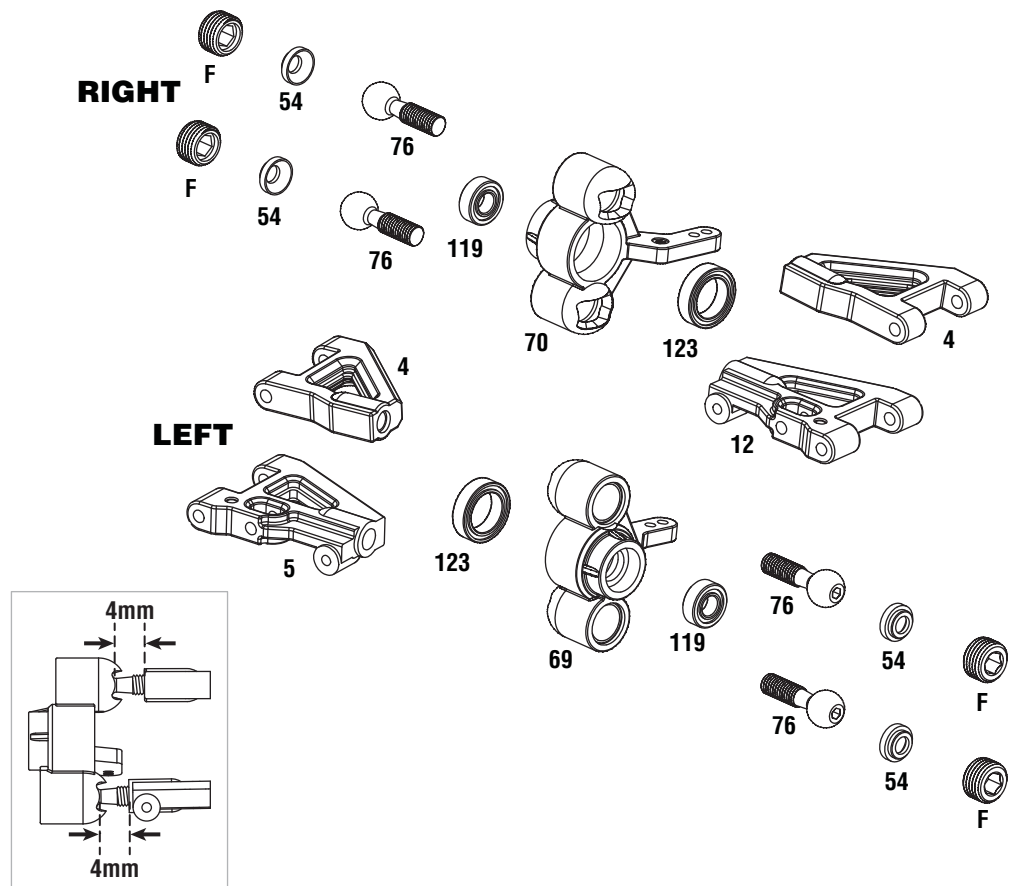



8

C (x2)
2x11mm

72 (x2)
35mm

73 (x2)
50mm

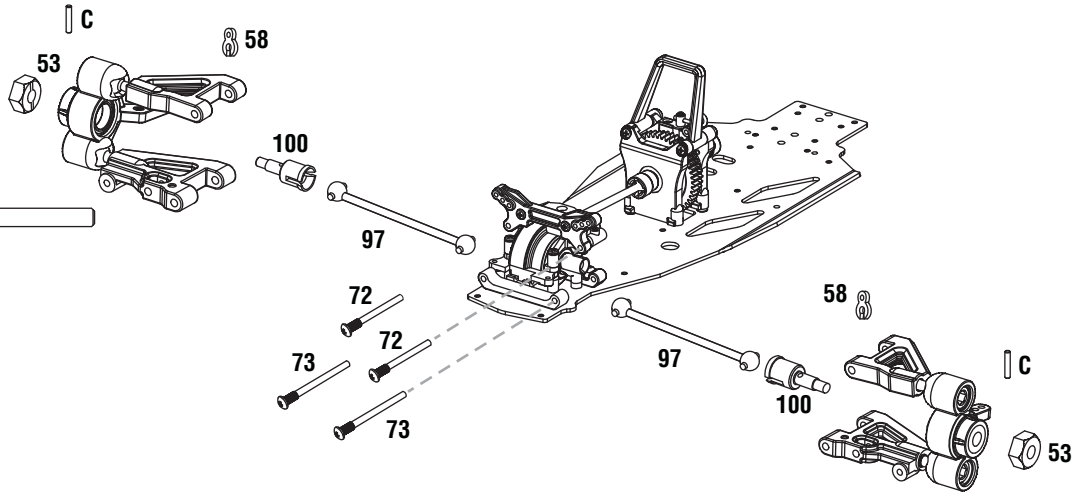

9

W (x2)
3x12mm

BB (x2)
3x10mm

RR (x2)
3x5mm

ZZ (x4)
6.8x6mm

77 (x2)
26mm

112 (x2)
4x26mm

119 (x2)
5x11mm

123 (x2)
10x15mm

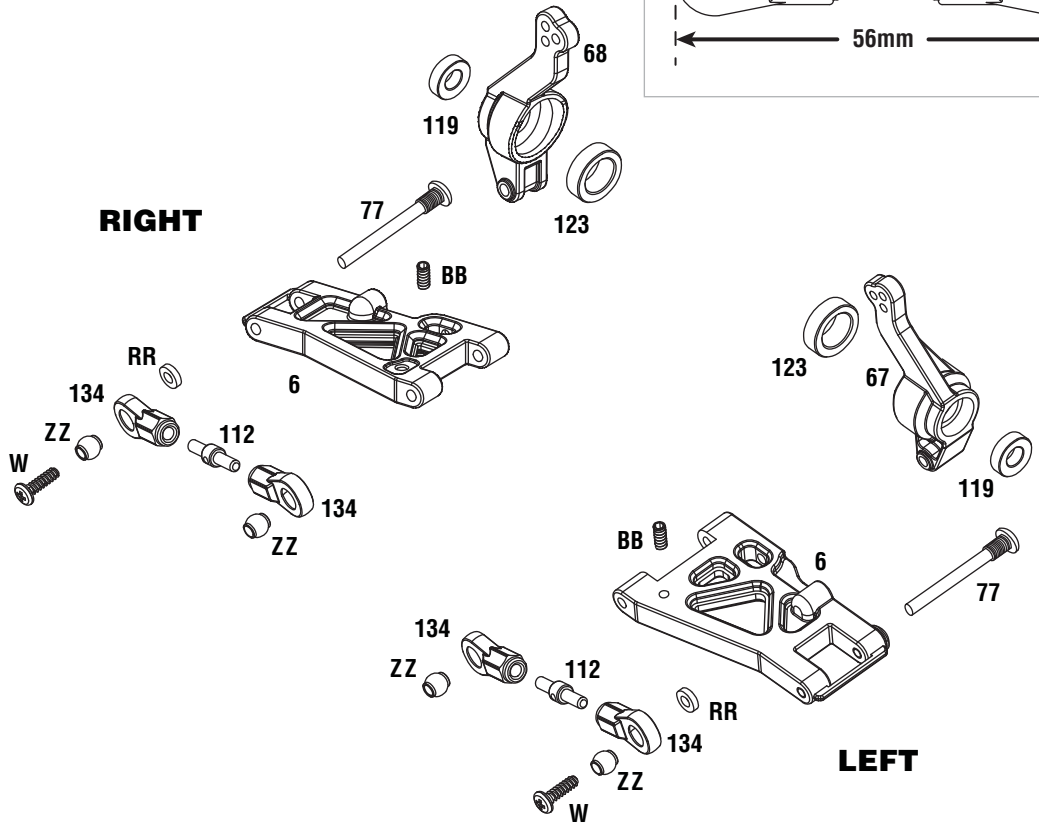



10



M (x2)
2x10mm



Q (x2)
3x10mm



HH (x8)
3x10mm



NN (x2)
3x12mm

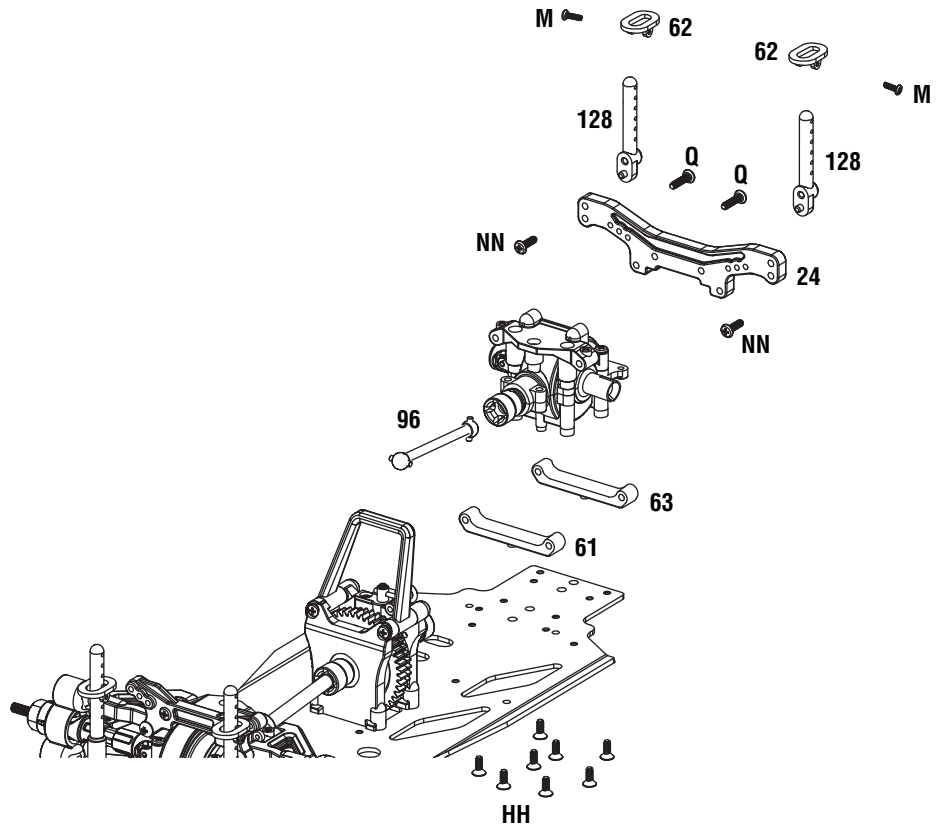

11

C (x2)
2x11mm

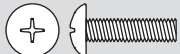

W (x2)
3x12mm



74 (x2)
22mm



75 (x2)
54mm

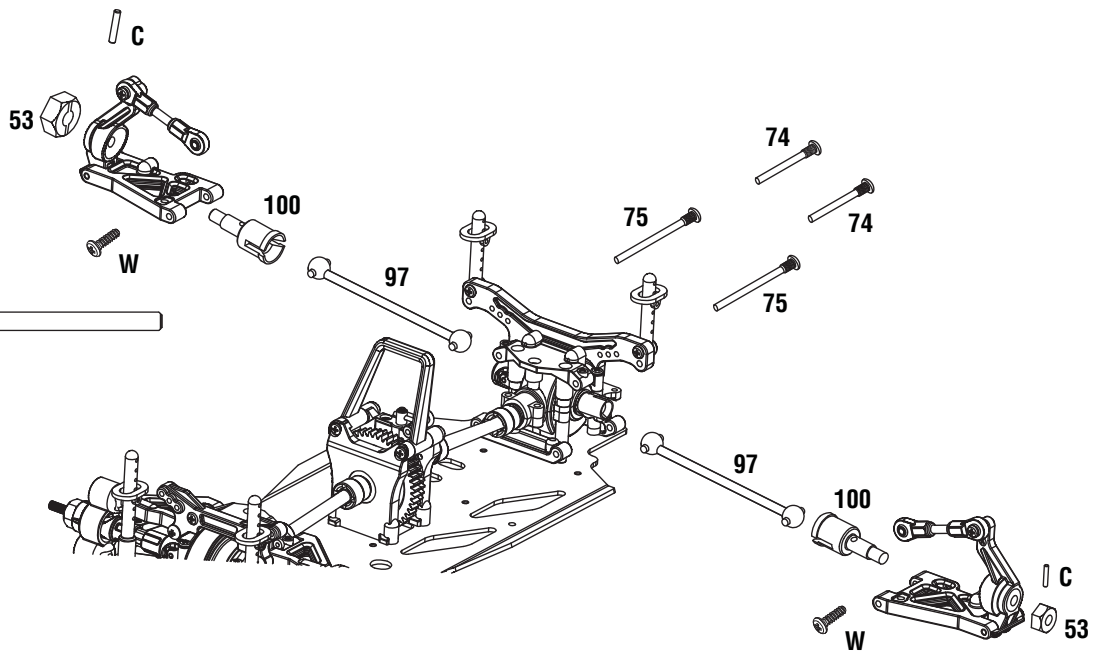



M (x2)
2x10mm



Q (x2)
3x10mm

12

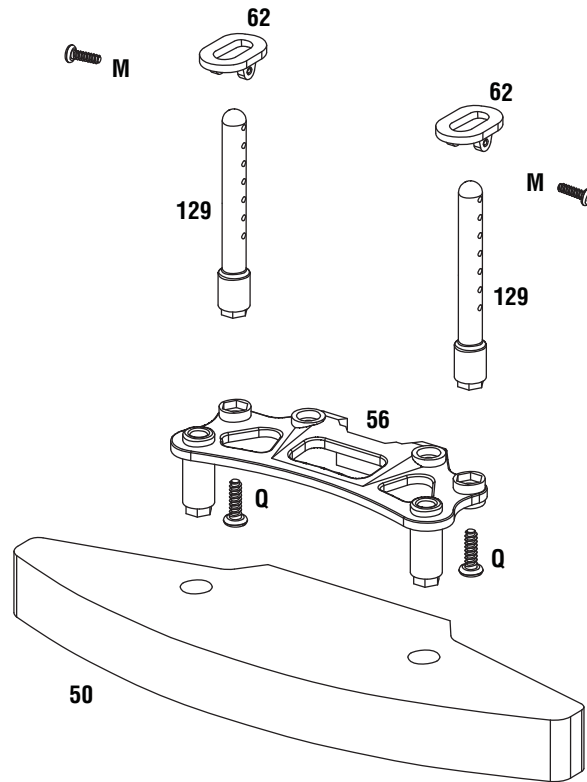

H (x2)
3mm



P (x2)
3x8mm



Q (x2)
3x10mm



Y (x2)
3x10mm

13

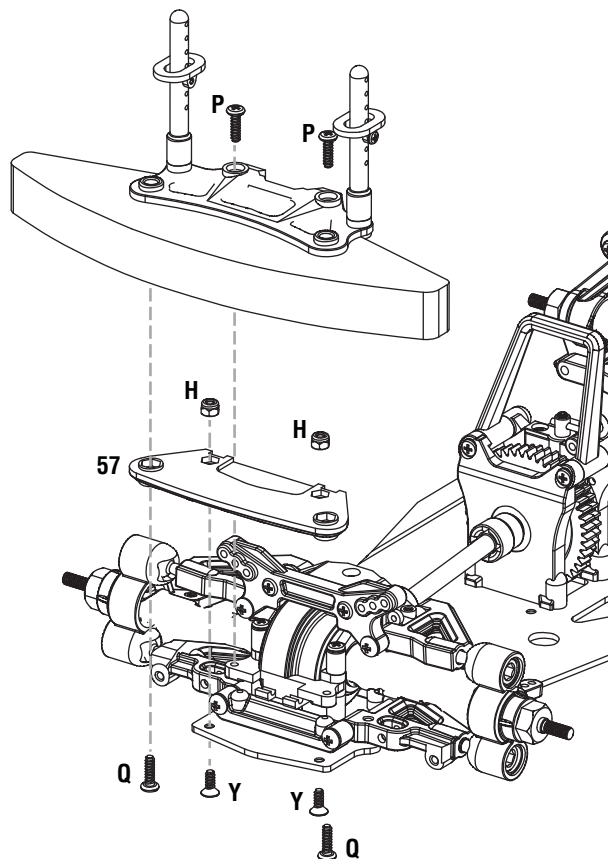

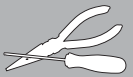

TT (x2)
2.5mm

14

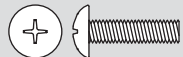
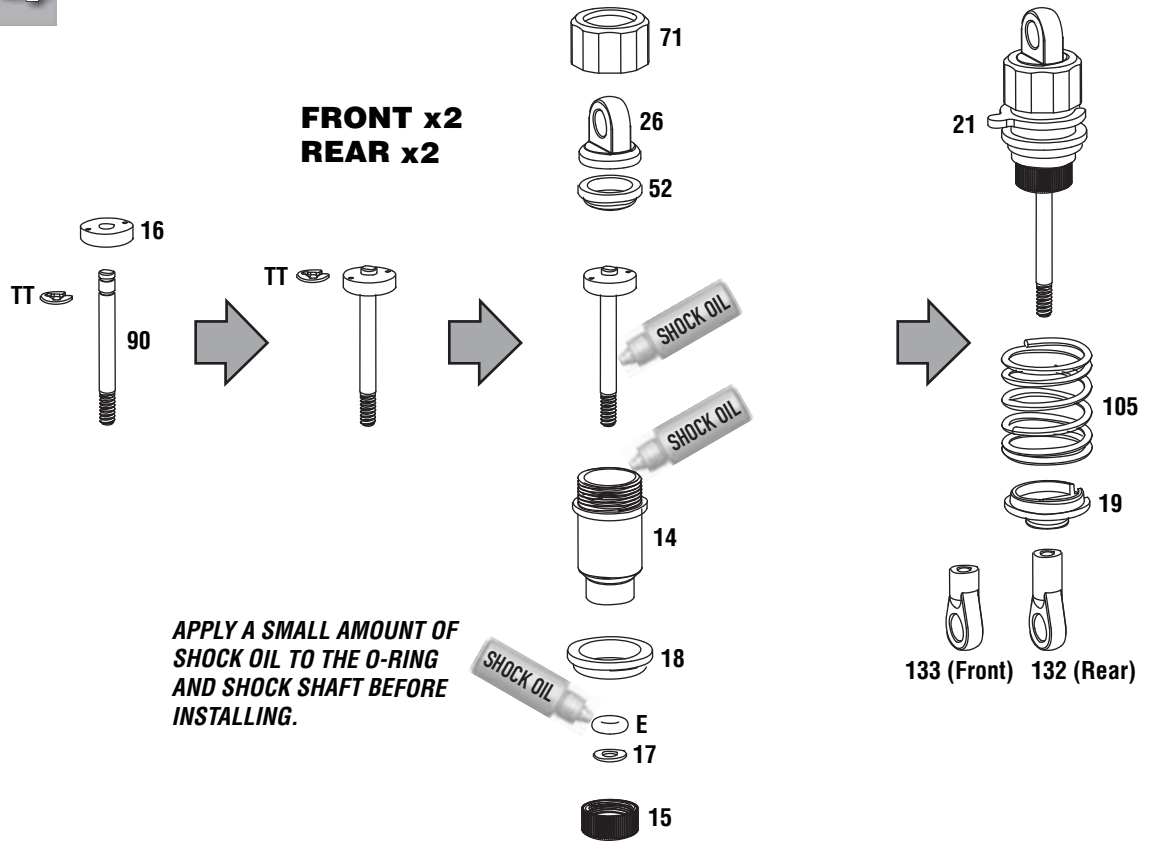

W (x4)
3x12mm



RR (x4)
3x5mm



YY (x2)
5.8x5.5mm

15

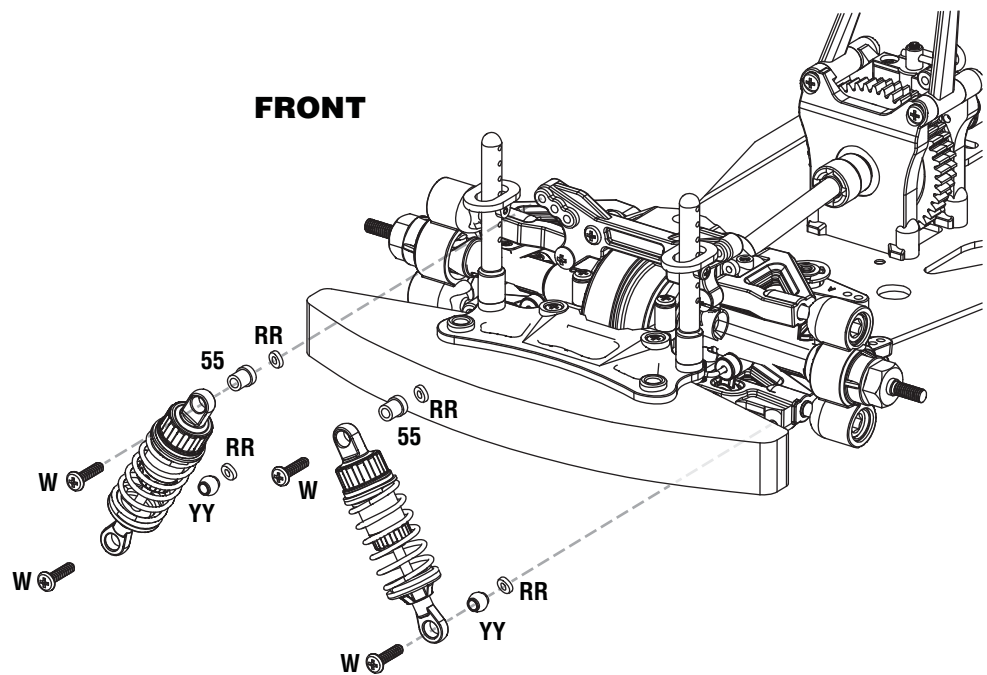

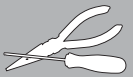

16

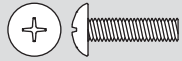

W (x4)
3x12mm



RR (x4)
3x5mm



YY (x2)
5.8x5.5mm

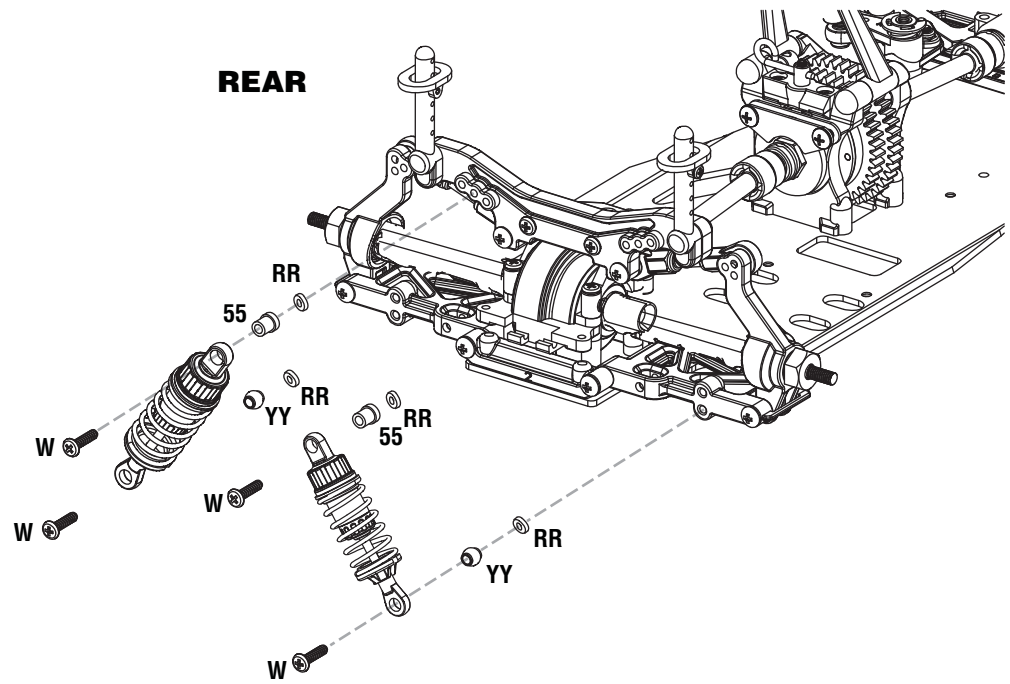

17



UU (x3)
4mm





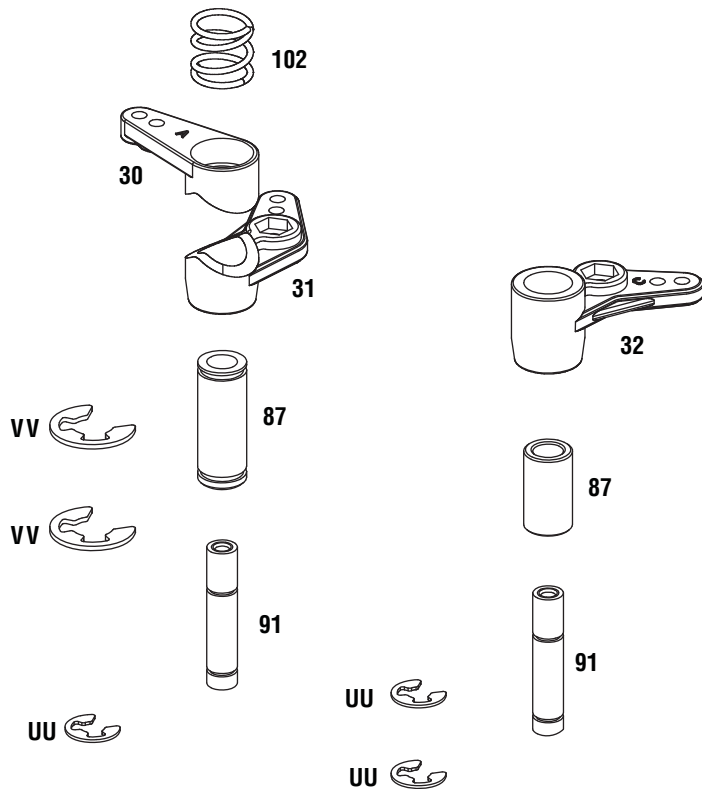

VV (x2)
7mm



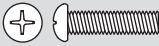



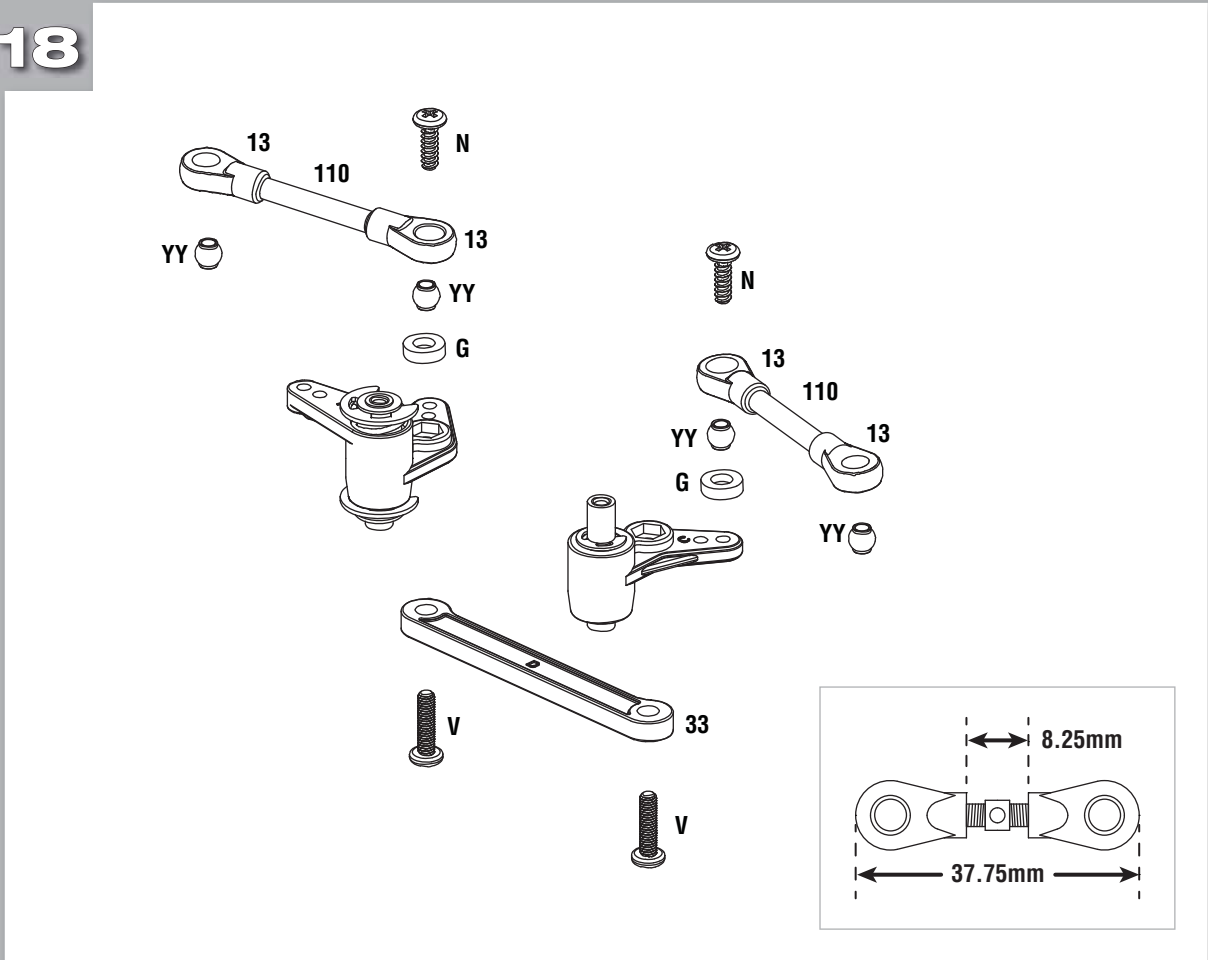

18

-  G (x2)
3x5mm
-  N (x2)
3X12mm
-  V (x2)
3X10mm
-  YY (x4)
5.8X5.5mm
-  110 (x2)
3x16mm

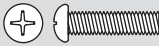

19

-  N (x2)
3x12mm
-  R (x2)
3x15mm
-  X (x2)
3x8mm
-  Z (x1)
3x10mm
-  RR (x2)
3X5mm

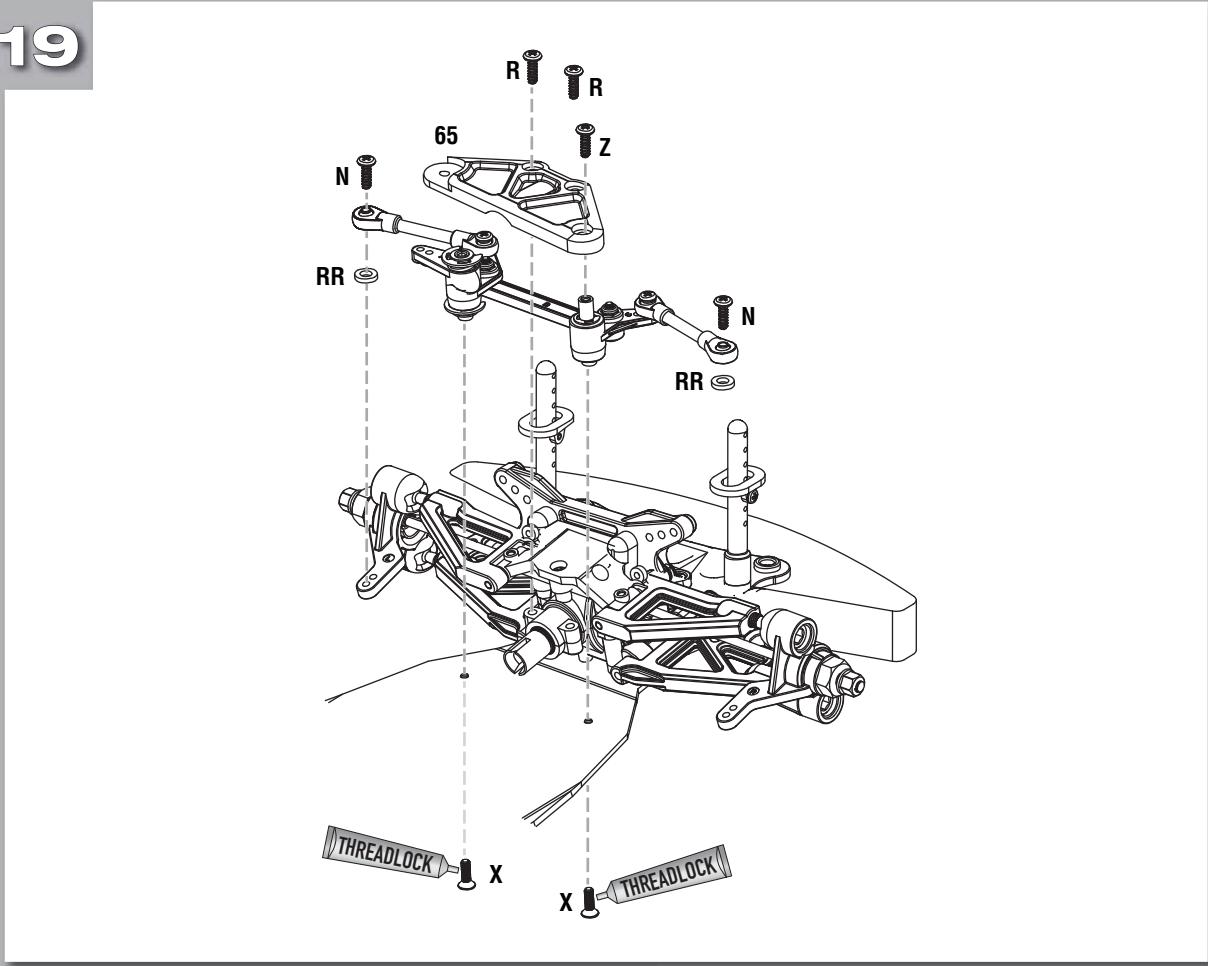

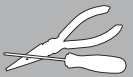

20



R (x1)
3x15mm



GG (x2)
3X30mm



80 (x2)
3mm

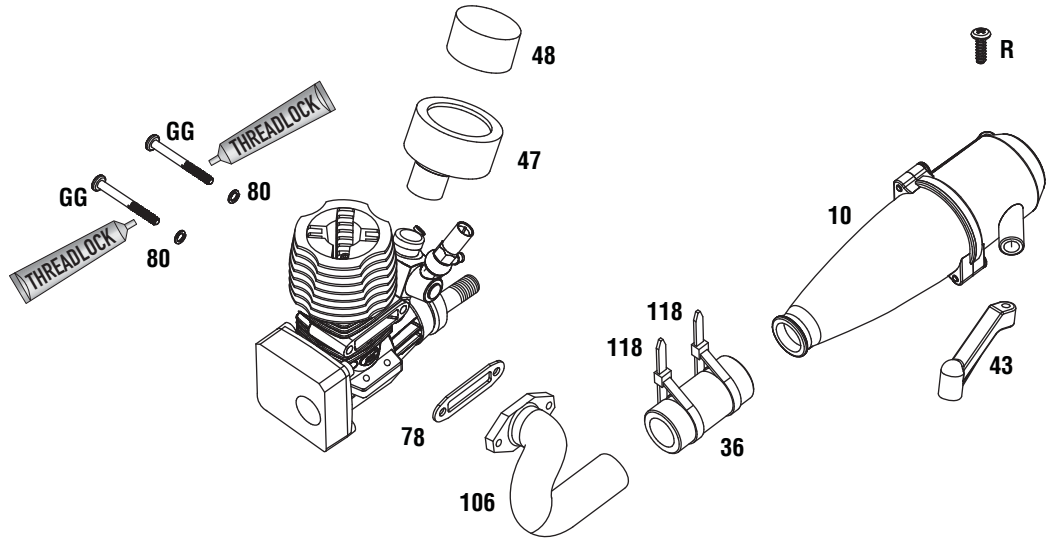

21



EE (x1)
3x8mm

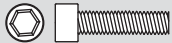

FF (x4)
3x12mm



PP (x1)
3x6mm



QQ (x2)
5x8mm



80 (x4)
3mm



120 (x2)
5x10mm

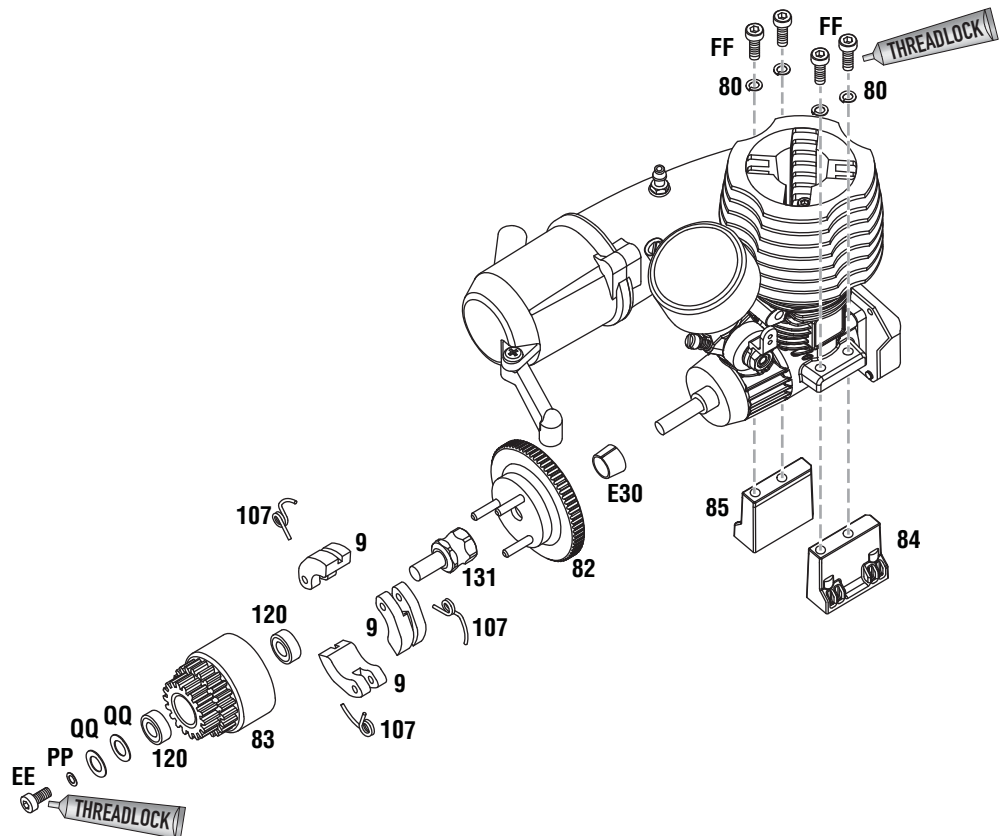



22

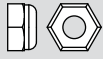

H (x4)
3mm

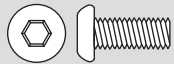

K (x4)
4x10mm

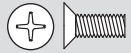

X (x4)
3x8mm



HH (x1)
3x10mm

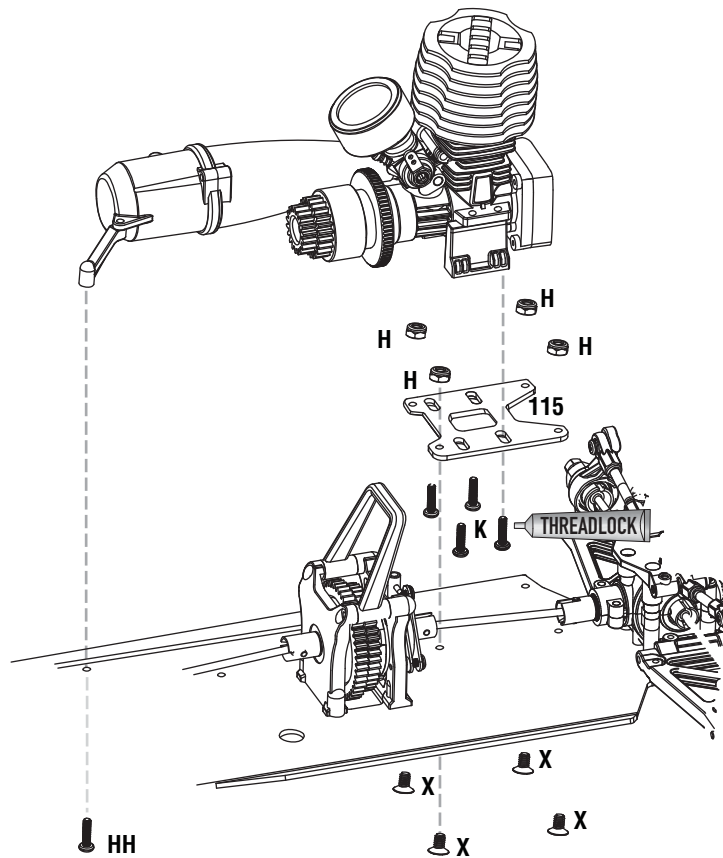

23



Q (x3)
3x10mm



U (x9)
3x8mm

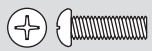

Z (x1)
3x10mm



YY (x2)
5.8x5.5mm



111 (x1)
3x28mm

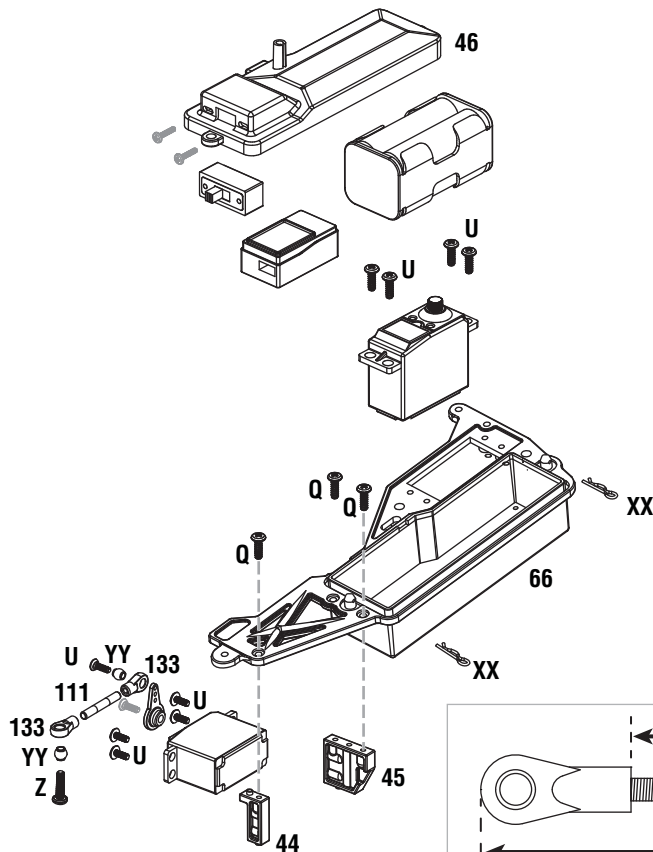

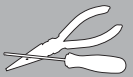

HH (x2)
3x10mm

24

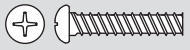
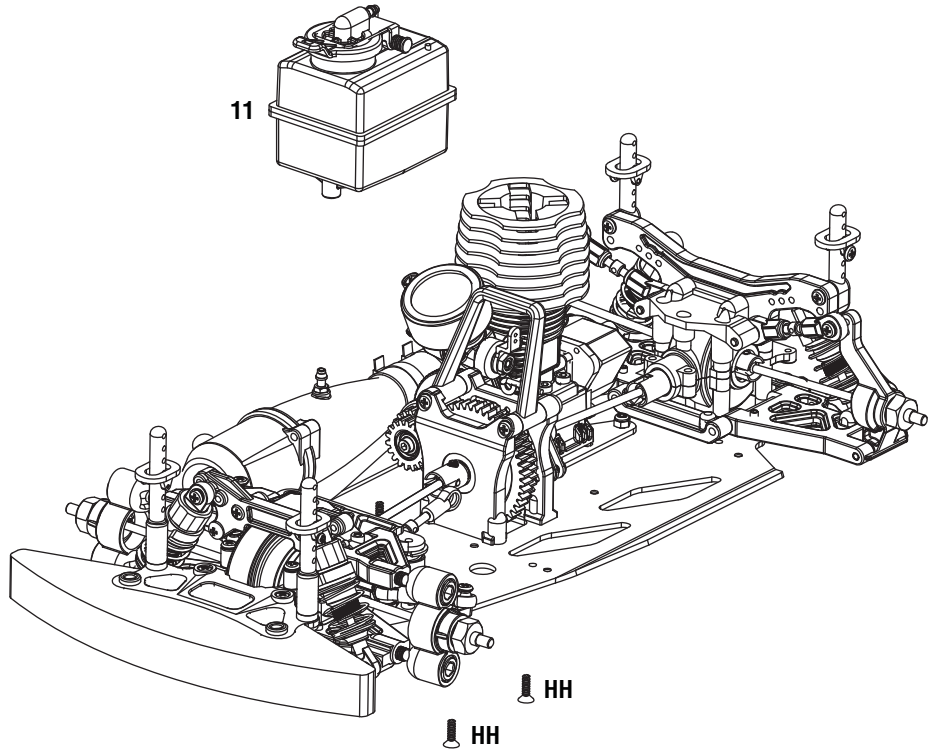

R (x2)
3x15mm



Z (x1)
3x10mm



AA (x3)
3x3mm



HH (x3)
3x10mm



KK (x1)
2x8mm



PP (x1)
3x6mm

25

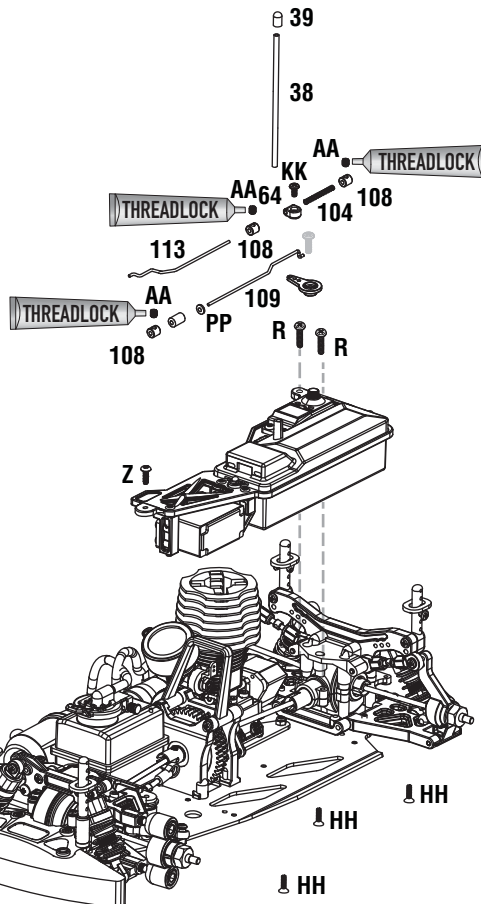

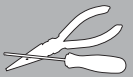

J (x4)
4mm

26

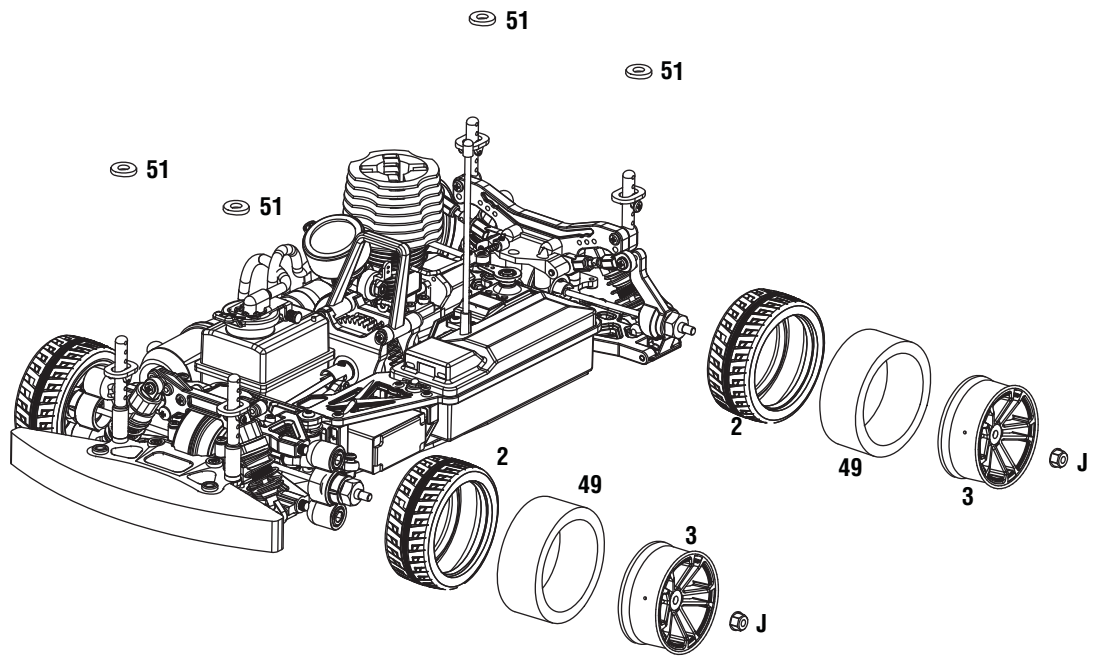

**USE TIRE GLUE (DTXR2002) TO
BOND THE TIRES TO THE RIMS.**



B (x4)
2x4mm



AAA (x2)
4mm

27

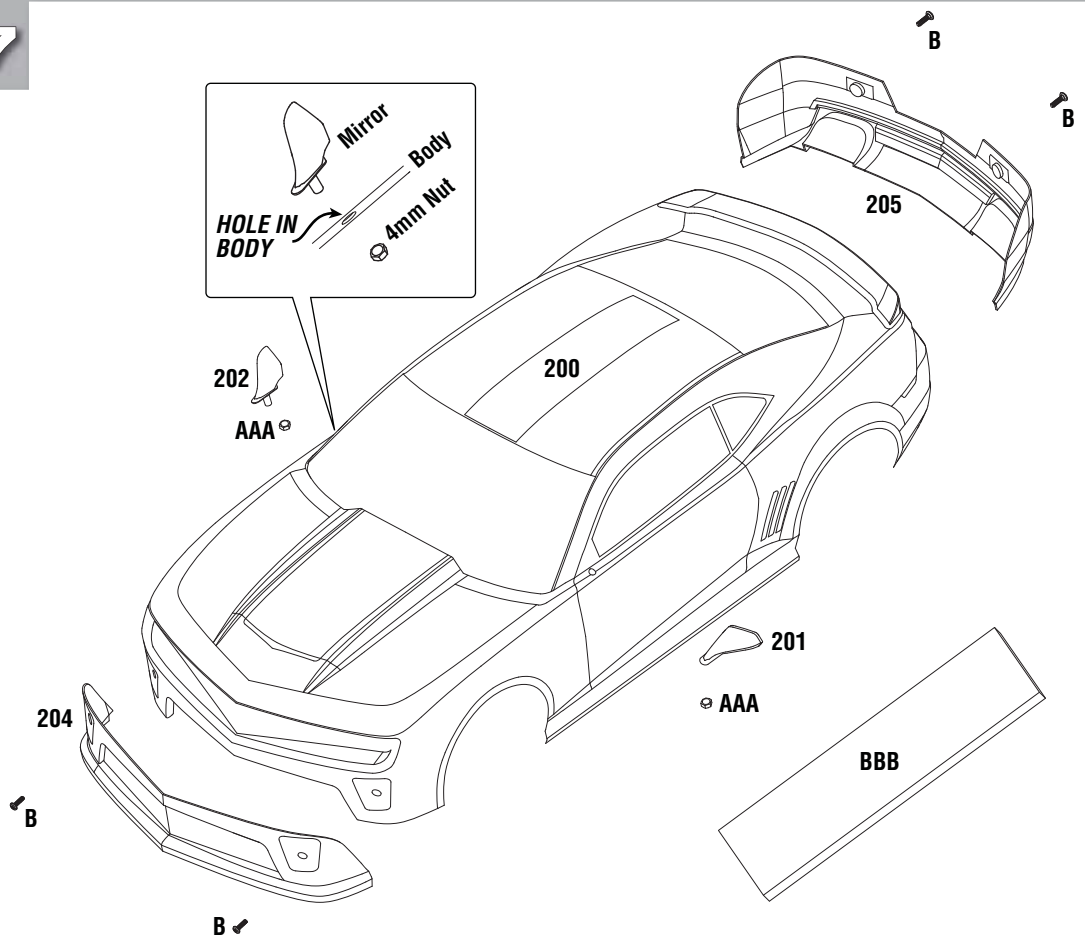

REPLACEMENT PARTS

PARTS LISTS, PARTS SETS, AND EXPLODED VIEWS

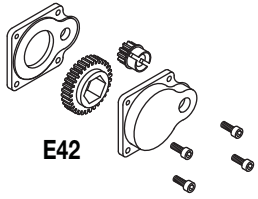

**Super Start Backplate
DTXP6026**

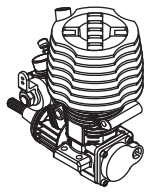

**.18 Engine
SUPG0600**



**Carburetor Complete
SUPG1750**

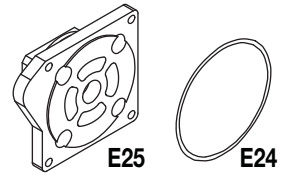

**Backplate w/Gasket
SUPG2051**

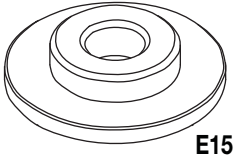

**Head Button
SUPG2180**

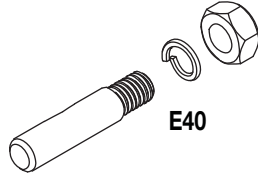

**Carburetor Bolt
SUPG2360**

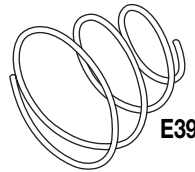

**Throttle Spring
SUPG2440**

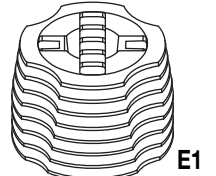

**Cooling Head
SUPG2451**



**Connecting Rod
SUPG2520**

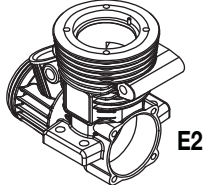

**Crankcase
SUPG2615**

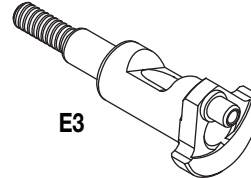

**Crankshaft
SUPG3111**

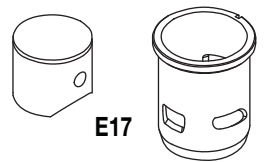

**Cylinder & Piston
SUPG3387**

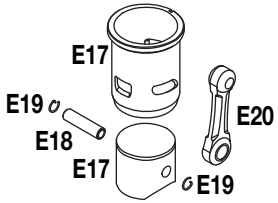

**Cyl-Piston-Rod Assm
SUPG3388**

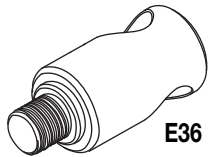

**Carburetor Rotor
SUPG4202**



**Rotor Boot Cover
SUPG4220**

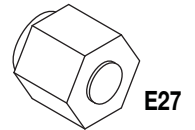

**One-Way Bearing
SUPG4430**

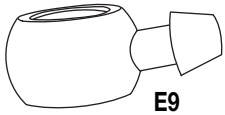

**Fuel Nipple
SUPG4476**



**Idle Screw Spring
SUPG4710**



**High Speed Needle
SUPG4840**

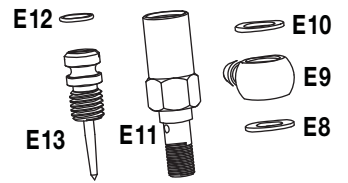

**Needle Valve Assembly
SUPG4881**

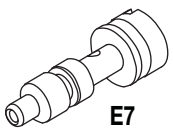

**Low Speed Needle
SUPG4900**

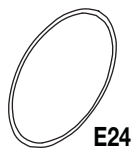

**Backplate Gasket
SUPG5020**



**High Speed Needle
Valve O-Ring
SUPG5021**



**Starting Shaft O-Ring
SUPG5060**

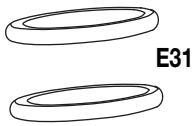

E31

**Carburetor O-Ring
SUPG5061**

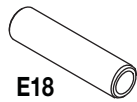

E18

**Piston Pin
SUPG5095**



E19

**Piston Pin Retainers
SUPG5099**



E21

**Starting Pressure Spring
SUPG5420**



E5

**Front Bearing
SUPG5464**

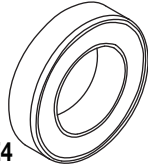

E4

**Rear Bearing
SUPG5466**

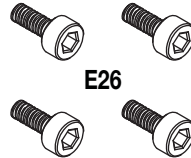

E26

**Backplate Screws
SUPG5650**

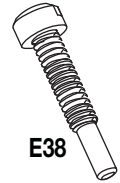

E38

**Idle Stop Screw
SUPG5652**

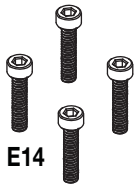

E14

**Cooling Head Screws
SUPG5653**

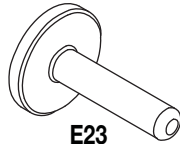

E23

**Starting Shaft
SUPG5870**

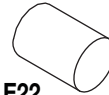

E22

**Starting Pin
SUPG5880**

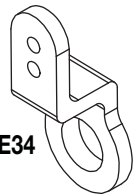

E34

**Throttle Arm
SUPG6050**

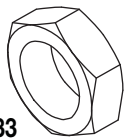

E33

**Throttle Arm Nut
SUPG6058**

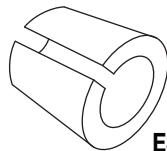

E30

**Brass Collet
SUPG6076**



E6

**Carburetor Body
SUPG6202**



E8

**Lower Needle
Valve Washer
SUPG6350**



E10

**Upper Needle
Valve Washer
SUPG6351**

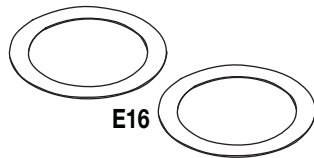

E16

**Head Shims
SUPG6353**



E41

**Throttle Arm Washer
SUPG6355**



ENGINE PARTS

This parts list shows the key number, part description, and stock number for the replacement parts sets. When more than one stock number is listed, that part is available in multiple replacement parts sets. For contents found in each replacement parts set, refer to the illustrated parts guide.

E1	Cooling Head	SUPG2451
E2	Crankcase.....	SUPG2615
E3	Crankshaft w/10mm Threaded Shaft	SUPG3111
E4	Ball Bearing (Rear)	SUPG5466
E5	Ball Bearing (Front).....	SUPG5464
E6	Carburetor Body	SUPG6202, SUPG1750
E7	Low Speed Needle	SUPG4900, SUPG1750
E8	Lower Needle Valve Washer	SUPG6350, SUPG4881, SUPG1750
E9	Fuel Nipple.....	SUPG4476, SUPG4881, SUPG1750
E10	Upper Needle Valve Washer	SUPG6351, SUPG1750
E11	High Speed Needle Valve Hub..	SUPG4881, SUPG1750
E12	High Speed Needle Valve O-Ring.....	SUPG5021, SUPG4881, SUPG1750

E13	High Speed Needle.....	SUPG4840, SUPG4881, SUPG1750
E14	Cooling Head Screws	SUPG5653
E15	Head Button.....	SUPG2180
E16	Head Shim	SUPG6353
E17	Cylinder Sleeve/Piston.....	SUPG3387, SUPG3388
E18	Piston Pin.....	SUPG5095, SUPG3388
E19	Piston Pin Retainers	SUPG5099, SUPG3388
E20	Connecting Rod	SUPG2520, SUPG3388
E21	Starting Pressure Spring	SUPG5420
E22	Starting Pin	SUPG5880
E23	Starting Shaft.....	SUPG5870
E24	Backplate Gasket.....	SUPG5020, SUPG2051
E25	Backplate w/Gasket	SUPG2051
E26	Backplate Screws	SUPG5650
E27	One-Way Bearing	SUPG4430
E28	Starting Shaft O-Ring	SUPG5060
E30	Brass Collet	SUPG6076
E31	Carburetor O-Ring	SUPG5061
E33	Throttle Arm Nut	SUPG6058, SUPG1750
E34	Throttle Arm	SUPG6050, SUPG1750
E35	Rotor Boot Cover	SUPG4220, SUPG1750
E36	Carburetor Rotor.....	SUPG4202, SUPG1750
E37	Idle Screw Spring.....	SUPG4710, SUPG1750
E38	Idle Stop Screw.....	SUPG5652, SUPG1750
E39	Throttle Spring	SUPG2440, SUPG1750
E40	Carburetor Bolt	SUPG2360
E41	Throttle Arm Washer.....	SUPG6355
E42	Super Start Backplate.....	DTXP6026

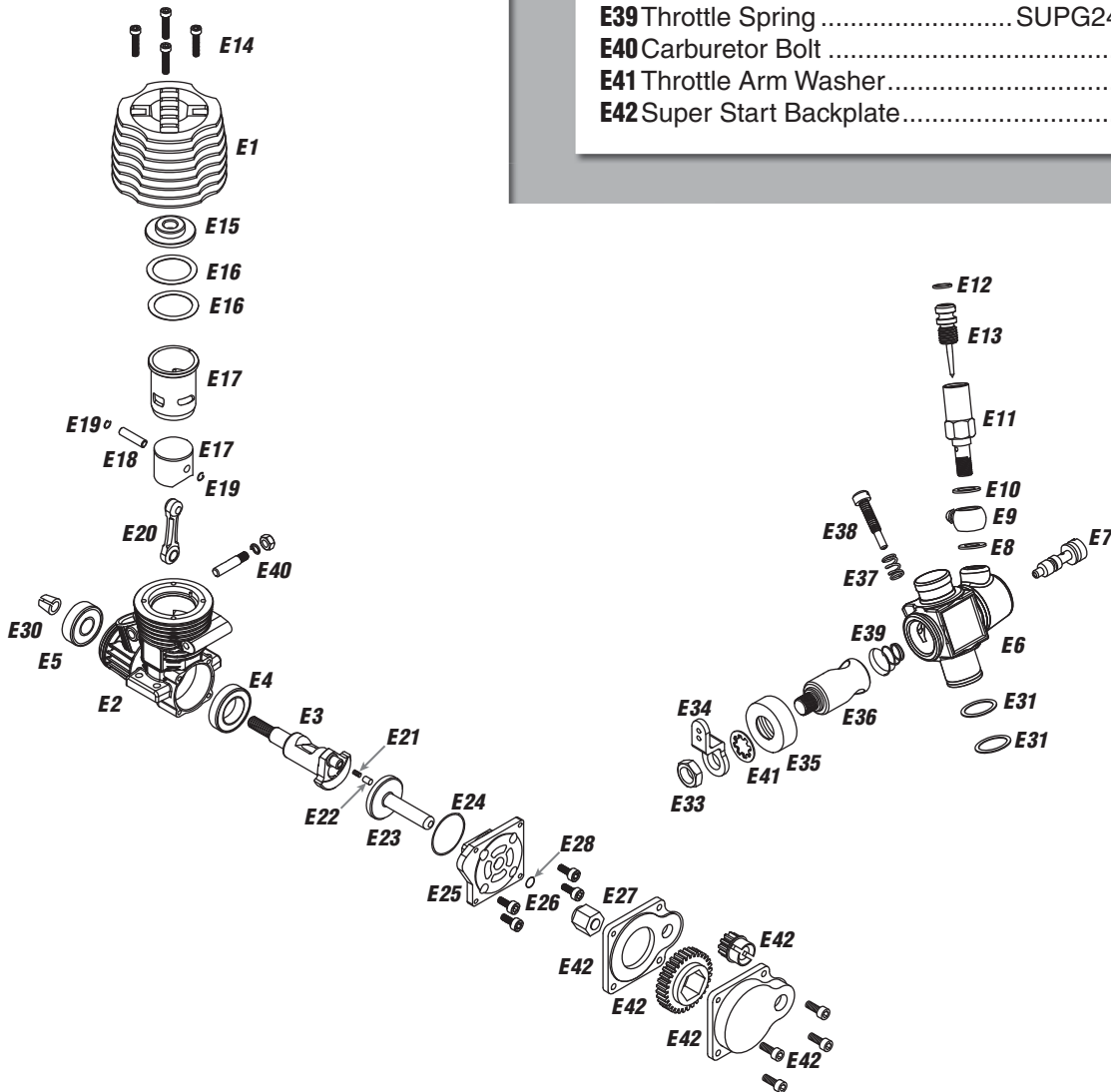

Tools & Accessories

Body Scissors & Reamer

Stainless steel blades of body scissors cut through plastics without tearing. The reamer has a sharp tip with fluted blades to remove debris as you cut.

- DTXR1150 Curved Tip Body Scissors
- DTXR1151 Straight Tip Body Scissors
- DTXR1158 Body Reamer
- DTXR1160 Straight Tip Body Scissors & Reamer (2-Piece Set)
- DTXR1161 Straight/Curved Tip Body Scissors & Reamer (3-Piece Set)



Pit Tech™ Camber Gauge

Made of durable black plastic, this gauge easily and accurately measures camber settings in 1° increments from 10° positive to 10° negative.

DTXR1146



Pit Tech Tire Glue

Specially formulated to form a lasting bond between your wheels and rubber tires, Tire Glue comes in two 0.5 oz (14.8 mL) formulas: quicker-drying Thin and slower-curing Medium.

- DTXR2000 Thin
- DTXR2002 Medium



Body Repair Tape

Use this flexible, open-weave nylon mesh tape together with Shoe Goo to repair Lexan®, ABS plastic and wood. Rolls measure 2" x 6' (50.8 mm x 1.8 m).

DTXR1210



Pit Tech Threadlocker

This medium-strength threadlocking compound prevents metal fasteners from loosening under vibration. Each bottle contains 0.2 oz (5.9 mL). Not recommended for plastics.

DTXR2010



Servo Tape

Double-sided adhesive tape measures 1 in (25.4 mm) in width — perfect for standard servos, as well as many other sizes and applications. Contains 36 in (914.4 mm) per roll.

DTXR1215

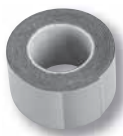

Shoe Goo® II

Clear, nonflammable Shoe Goo compound is strong, yet flexible when dry. It's ideal for body repairs, mounting servos, building battery packs and more.

DTXC2460



Metric Hardware Sets

These sets include the metric sizes and quantities that modelers use most, organized in a compact, 10-compartment plastic case.

- DTXQ0100 Phillips Head Screw Set (200 pc.)
- DTXQ0125 Socket Head Screw Set (124 pc.)
- DTXQ0150 Flat Head Screw Set (188 pc.)



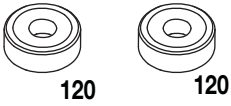

**5x10mm Ball Bearing
DTXC1535**

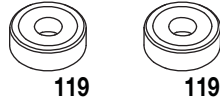

**5x11mm Ball Bearing
DTXC1547**

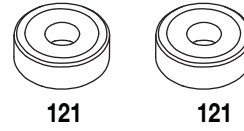

**6x12mm Ball Bearing
DTXC1569**

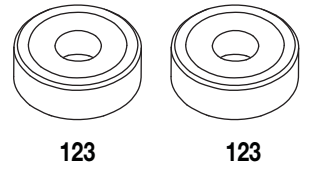

**10x15mm Ball Bearing
DTXC1595**

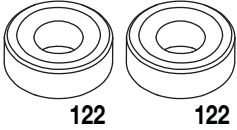

**10x19mm Ball Bearing
DTXC1705**

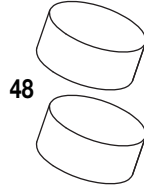

**Air Filter Element
DTXC6112**

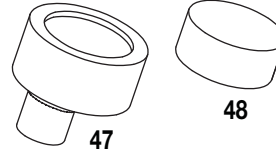

**Air Filter Set
DTXC6113**

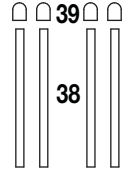

**Antenna Tube/Cap Set
DTXC6249**

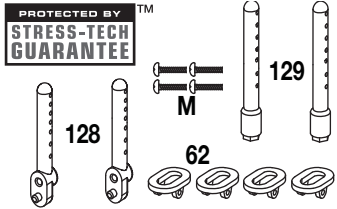

**Body Mount Set
DTXC6470**

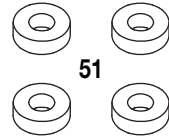

**Body Washers
DTXC6471**

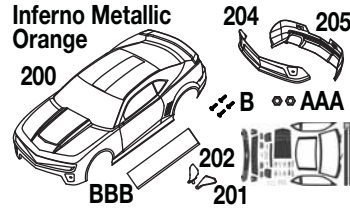

**Body w/Decal
DTXC6593**

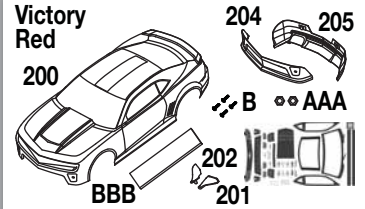

**Body w/Decal
DTXC6595**

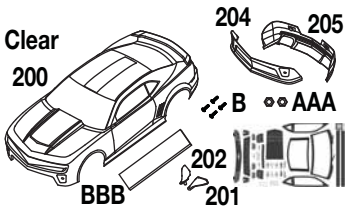

**Body w/Decal
DTXC6596**

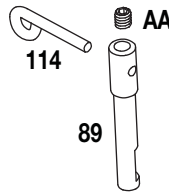

**Brake Cam Set
DTXC6754**

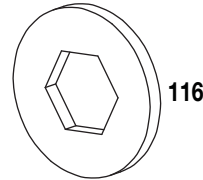

**Brake Disc
DTXC6755**

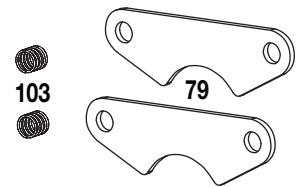

**Brake Plates w/Pads
DTXC6756**

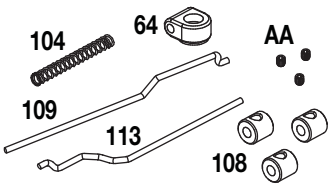

**Brake/Throttle Rod Set
DTXC6757**

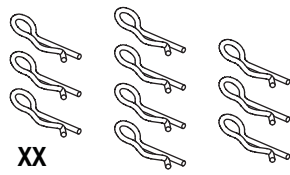

**Body Clip
DTXC6772**

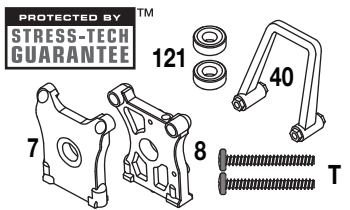

**Center Bulkhead Set
DTXC6818**

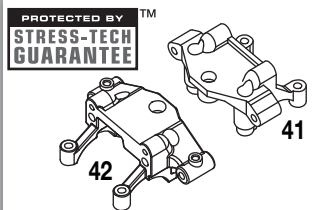

**Bulkhead Set
DTXC6819**

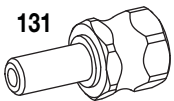

**Pilot Shaft
DTXC6881**

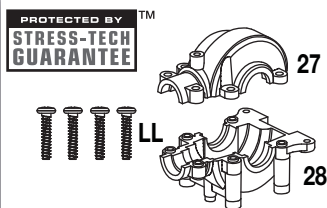

**Gear Box Set
DTXC6882**

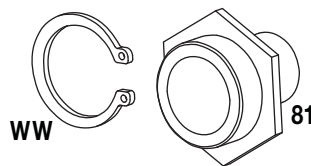

**Spur Gear Hub
w/One-Way Bearing
DTXC6883**

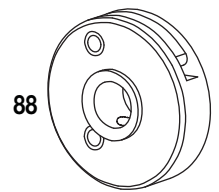

**2-Speed Clutch
DTXC6884**

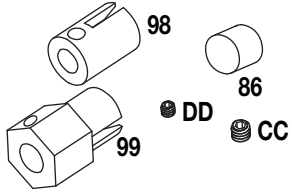

**Center Drive Joint Set
DTXC6885**

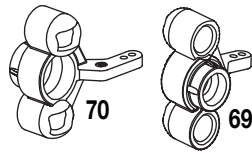

**Knuckle Arm Set
DTXC6886**

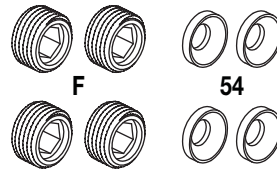

**Pillow Ball Retainer Set
DTXC6887**

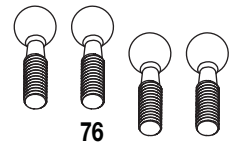

**Pillow Ball Set
DTXC6888**

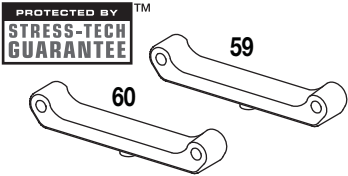

**Front Hinge Pin
Mount Set
DTXC6889**

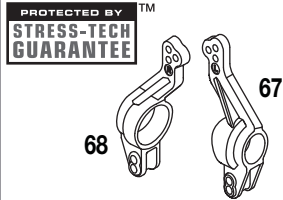

**Rear Hub Set
DTXC6890**

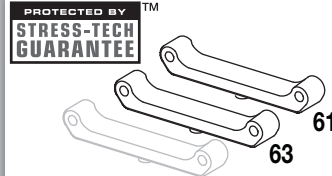

**Rear Hinge Pin
Mount Set
DTXC6891**

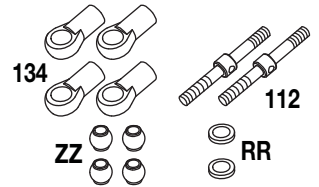

**Camber Rod Set
DTXC6892**

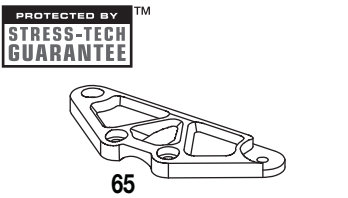

**Front Brace
DTXC6893**

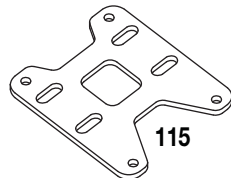

**Engine Mount Plate
DTXC6894**

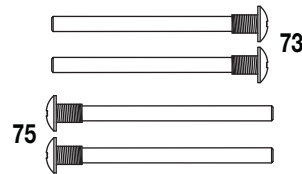

**Hinge Pins (50/54mm)
DTXC6895**

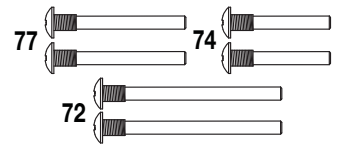

**Hinge Pins
(22/26/35mm)
DTXC6896**

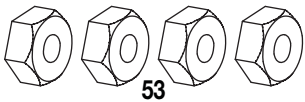

**Hex Drive Washer
DTXC6897**

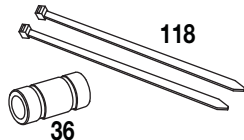

**Exhaust Coupler
DTXC6898**

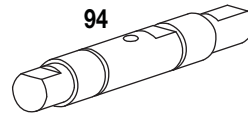

**Center Shaft
DTXC6899**

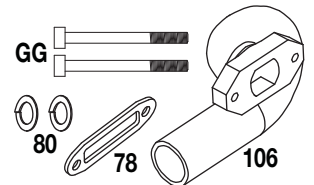

**Manifold Set
DTXC6900**

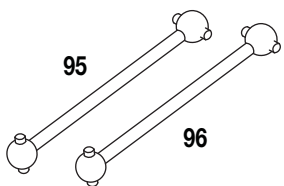

**Center Dogbone Set
(56/64mm)
DTXC6901**

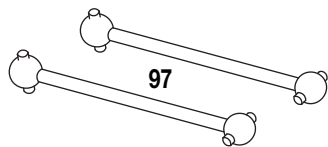

**Dogbone (60mm)
DTXC6902**

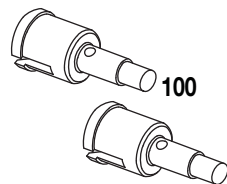

**Wheel Shaft Set
DTXC6903**

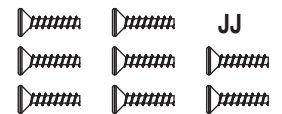

**2x8mm
F/H S/T Screws
DTXC6905**

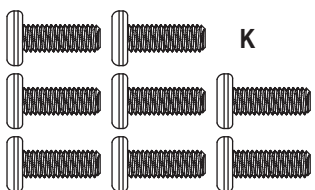

**4x10mm H/H Screws
DTXC6906**



**2x11mm Pin
DTXC6907**



**2x10mm Pin
DTXC6908**

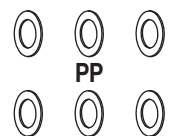

**3x6x0.3mm Shim
DTXC6909**

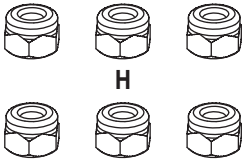

H

**3mm Lock Nut
DTXC6911**

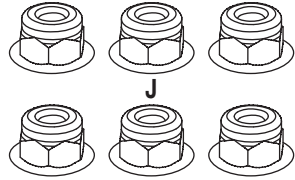

J

**Flanged Wheel Nuts
DTXC6912**

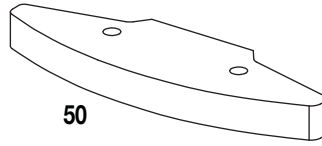

50

**Foam Bumper
DTXC6913**

PROTECTED BY
STRESS-TECH
GUARANTEE

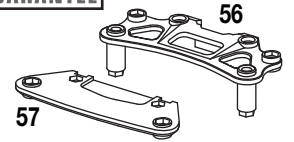

57

**Bumper Mount Set
DTXC6914**

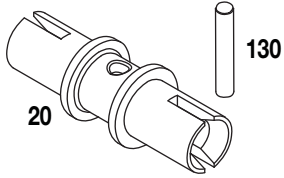

130

20

**Differential Spool Set
DTXC6917**

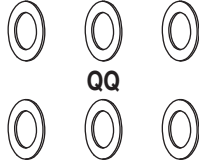

QQ

**5x8x.3mm Shim
DTXC6918**

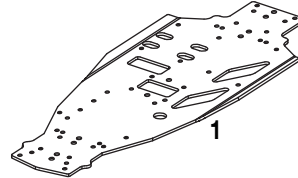

1

**Main Chassis
DTXC7032**

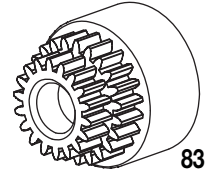

83

**Clutch Bell (17T/22T)
DTXC7149**

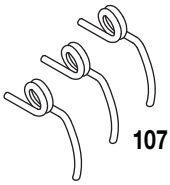

107

**Clutch Springs
DTXC7161**

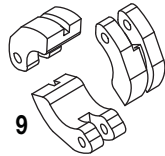

9

**Clutch Shoes
DTXC7162**

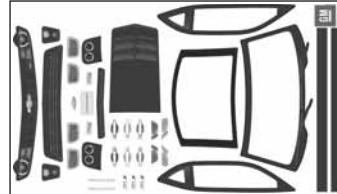

**Decal Sheet
DTXC7296**

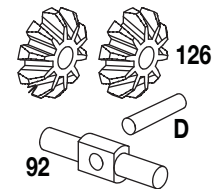

126

92

**Diff Bevel Gear Set
DTXC7387**

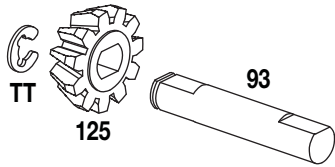

TT

125

93

**Diff Pinion Gear/Shaft
DTXC7388**

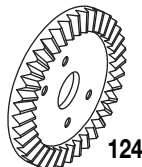

124

**Ring Gear (34T)
DTXC7398**

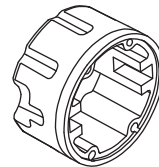

29

JJ

**Differential Case
DTXC7399**

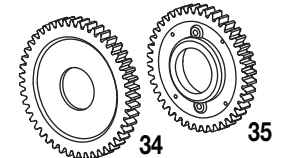

34

35

**Spur Gear Set
(41T, 47T)
DTXC7496**

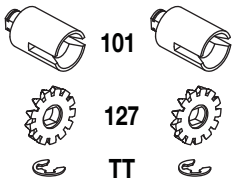

101

127

TT

**Diff Drive Joint/Gear
DTXC7497**

DD

98

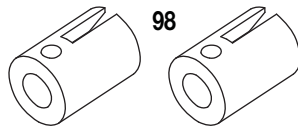

**Drive Shaft Joint
DTXC7498**

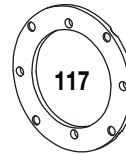

117

MM

**Spur Gear Plate
DTXC7499**

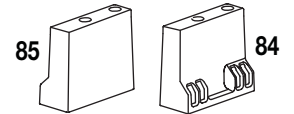

85

84

FF 80

**Engine Mount Set
DTXC7617**

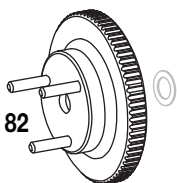

82

**Flywheel
DTXC7711**

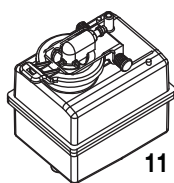

11

**Fuel Tank
DTXC7820**

PROTECTED BY
STRESS-TECH
GUARANTEE

XX

45

44

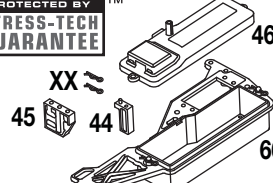

46

66

**Radio Tray/Servo Mount Set
DTXC8410**

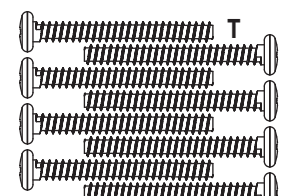

T

**3x28mm R/H S/T Screws
DTXC8643**

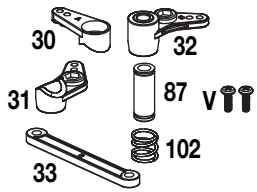

**Servo Saver Set
DTXC8788**

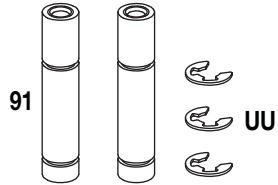

**Servo Saver Posts
DTXC8789**

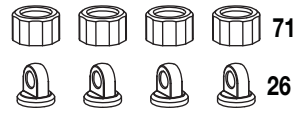

**Shock Cap Set
DTXC9069**

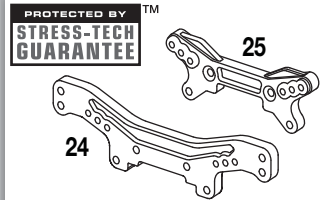

**Shock Tower Set
DTXC9074**

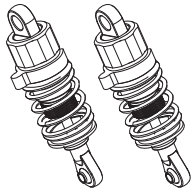

**Rear Shock Set
DTXC9075**

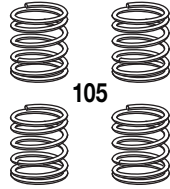

**Shock Springs
DTXC9076**

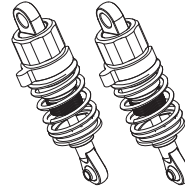

**Front Shock Set
DTXC9077**

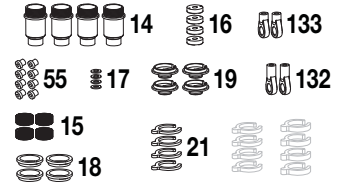

**Shock Plastic Parts
DTXC9078**

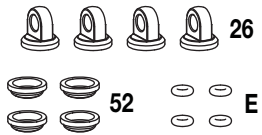

**Shock Seal Set
DTXC9079**



**Shock Shaft
DTXC9141**

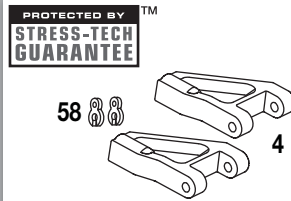

**Front Upper Susp Arms
DTXC9483**

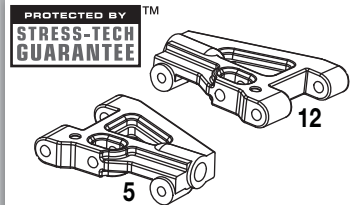

**Front Lower Susp Arms
DTXC9484**

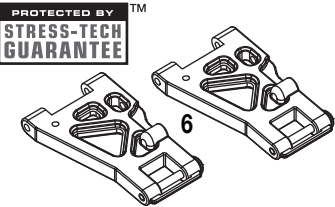

**Rear Lower Susp Arms
DTXC9485**

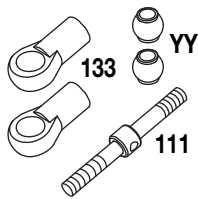

**Steering Rod Set
DTXC9568**

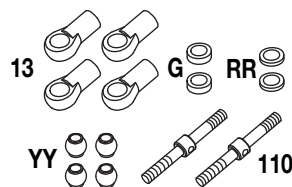

**Tie Rod Set
DTXC9649**

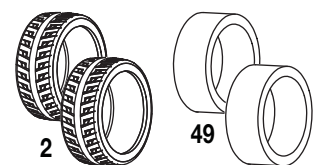

**Radial Tires
w/Foam Inserts
DTXC9679**

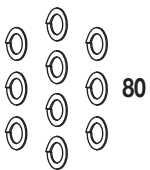

**3mm Spring Washer
DTXC9764**

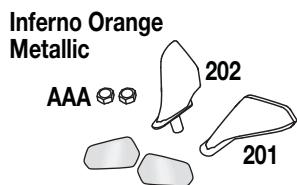

**Body Accessories
DTXC9785**

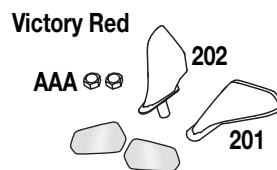

**Body Accessories
DTXC9787**

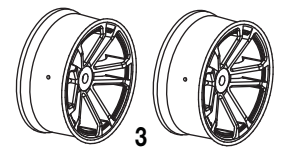

**Wheels
DTXC9791**

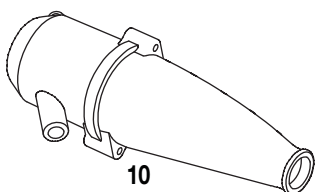

**Tuned Pipe
DTXC9933**

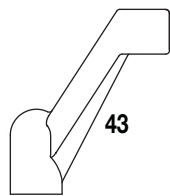

**Tuned Pipe Mount
DTXC9934**

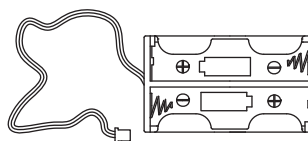

**Battery Box
DTXM3000**

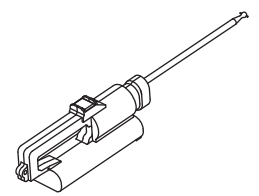

**Super Start
DTXP6023**

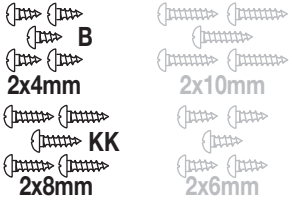

**2mm R/H S/T Screw Set
DTXQ0201**

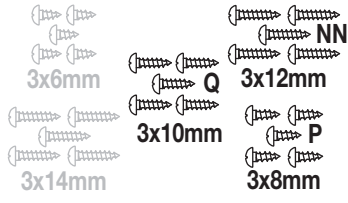

**3mm R/H S/T Screw Set
DTXQ0207**

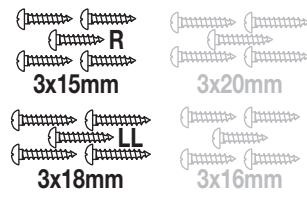

**3mm R/H S/T Screw Set
DTXQ0209**

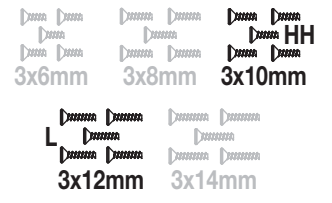

**3mm F/H S/T Screw Set
DTXQ0233**

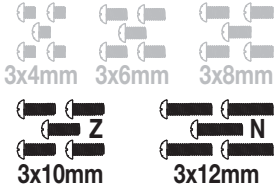

**3mm R/H Screw Set
DTXQ0255**

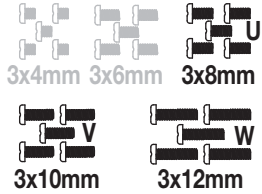

**3mm P/H Screw Set
DTXQ0263**

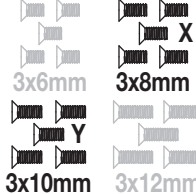

**3mm F/H Screw Set
DTXQ0273**

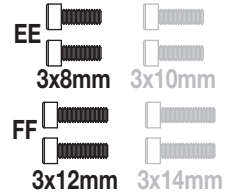

**3mm H/H Screw Set
DTXQ0285**

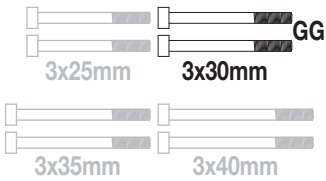

**3mm H/H Screw Set
DTXQ0287**

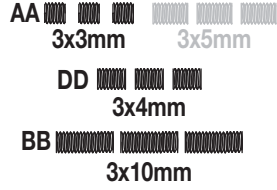

**3mm Set Screws
DTXQ0301**

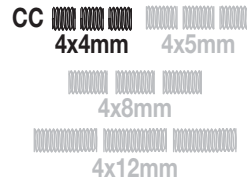

**4mm Set Screws
DTXQ0305**

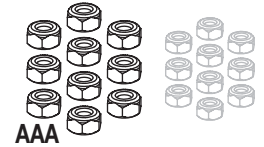

**4mm Nut
DTXQ0403**

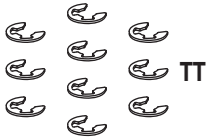

**2.5mm E-Clip
DTXQ0523**

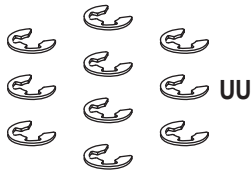

**4mm E-Clip
DTXQ0525**

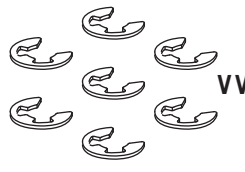

**7mm E-Clip
DTXQ0528**

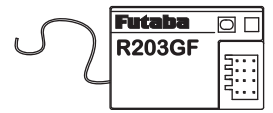

**R2036GF Receiver
FUTL7603**

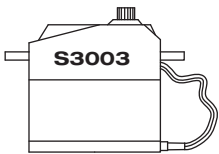

**Standard Servo
FUTM0031**

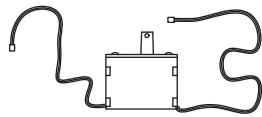

**Switch
FUTM4382**

Accessories

Glow Starters

The all-aluminum Ultra Slim is powered by a 1.2V, 1800mAh NiMH cell; Ultimates with high-impact polystyrene battery case use a larger NiCd. All include battery and charger — and offer the security of a Twist-and-Lock tip.

- DTXP0320 Ultra Slim "AA" Glow Starter
- DTXP0310 Ultimate "C" Glow Starter
- DTXP0315 Ultimate "D" Glow Starter



1/10 & 1/8 Universal Starter Box

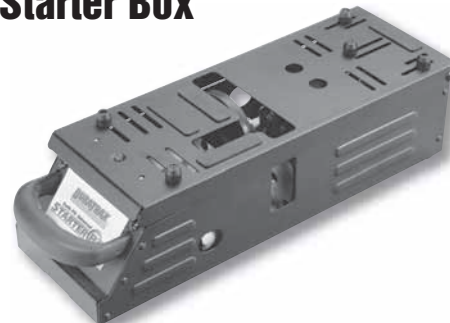

Twin 550 motors and a durable belt drive offer reliable starting power for 1/8 and 1/10 on- and off-road engines. Requires either a 12V, 7Ah field battery or two 6-cell NiCd/NiMH stick packs.

DTXP5701

Micro Fail-Safe

Prevents runaways due to signal loss or low receiver battery voltage, by reducing the throttle to a setting you select. Works with 4- and 5-cell NiCd and NiMH packs. Universal connector included.

DTXM4000



NiMH Receiver Battery & Charger



Use the 4.23 oz. DTX 1400 NiMH to power your receiver — recharge the pack from AC or DC input with the economical Onyx™ 100 charger. It features peak detection for NiCd and NiMH packs.

- DTXM2031 6.0V 1400mAh Hump NiMH Receiver Battery
- DTXP4190 Onyx 100 AC/DC Peak Charger

Futaba® 3PL 2.4GHz Computer Radio



Easy to program, the 3PL includes 3 proportional channels, a fourth for special mixing, and FHSS frequency-hopping technology to eliminate interference. A half-ounce R2004GF receiver is included.

FUTK1300



This parts list shows the key number, part description, and stock number for the replacement parts sets. When more than one stock number is listed, that part is available in multiple replacement parts sets. For contents found in each replacement parts set, refer to the illustrated parts guide.

#	Item Description	Available in Stock #
1	Main Chassis	DTXC7032
2	Radial Tire	DTXC9679
3	Wheel	DTXC9791
4	Front Upper Suspension Arm	DTXC9483
5	Front Lower Suspension Arm (Left)	DTXC9484
6	Rear Lower Suspension Arm	DTXC9485
7	Center Bulkhead (Front)	DTXC6818
8	Center Bulkhead (Rear)	DTXC6818
9	Clutch Shoes	DTXC7162
10	Tuned Pipe	DTXC9933
11	Fuel Tank	DTXC7820
12	Front Lower Suspension Arm (Right)	DTXC9484
13	Tie Rod Ball End	DTXC9649
14	Shock Body 23mm	DTXC9078, DTXC9075, DTXC9077
15	Shock Seal Retainer	DTXC9078, DTXC9075, DTXC9077
16	Shock Piston	DTXC9078, DTXC9075, DTXC9077
17	Shock Shim	DTXC9078, DTXC9075, DTXC9077
18	Upper Shock Spring Retainer	DTXC9078, DTXC9075, DTXC9077
19	Lower Shock Spring Retainer	DTXC9078, DTXC9075, DTXC9077
20	Differential Spool	DTXC6917
21	Shock Preload Spacer (1mm)	DTXC9078, DTXC9075, DTXC9077
24	Rear Shock Tower	DTXC9074
25	Front Shock Tower	DTXC9074
26	Shock Cap	DTXC9069, DTXC9079, DTXC9075, DTXC9077
27	Gear Box (Upper)	DTXC6882
28	Gear Box (Lower)	DTXC6882
29	Differential Case	DTXC7399
30	Bellcrank (Left, Upper)	DTXC8788
31	Bellcrank (Left, Lower)	DTXC8788
32	Bellcrank (Right)	DTXC8788
33	Steering Drag Link	DTXC8788
34	Spur Gear (Front, 47T)	DTXC7496
35	Spur Gear (Rear, 41T)	DTXC7496
36	Exhaust Coupler	DTXC6898
38	Antenna Tube (Black)	DTXC6249
39	Antenna Cap	DTXC6249
40	Center Bulkhead Handle	DTXC6818
41	Rear Bulkhead	DTXC6819
42	Front Bulkhead	DTXC6819
43	Tuned Pipe Mount	DTXC9934
44	Servo Mount (Front)	DTXC8410
45	Servo Mount (Rear)	DTXC8410
46	Radio Box Cover	DTXC8410
47	Air Filter Housing	DTXC6113
48	Air Filter Element	DTXC6112, DTXC6113
49	Foam Tire Insert	DTXC9679
50	Foam Bumper	DTXC6913
51	Body Washer	DTXC6471
52	Shock Diaphragm	DTXC9079, DTXC9075, DTXC9077
53	Hex Drive Washer	DTXC6897
54	Pillow Ball Spacer	DTXC6887
55	Shock Bushing	DTXC9078, DTXC9075, DTXC9077
56	Bumper Mount (Upper)	DTXC6914
57	Bumper Mount (Lower)	DTXC6914
58	Caster Clip	DTXC9483
59	Hinge Pin Mount (Front Fore)	DTXC6889
60	Hinge Pin Mount (Front Aft)	DTXC6889
61	Hinge Pin Mount 3° (Rear Fore)	DTXC6891
62	Body Mount Seat	DTXC6470
63	Hinge Pin Mount (Rear Aft)	DTXC6891
64	Throttle Slider	DTXC6757
65	Front Brace	DTXC6893
66	Radio Tray	DTXC8410
67	Rear Hub (Left)	DTXC6890
68	Rear Hub (Right)	DTXC6890
69	Knuckle Arm (Left)	DTXC6886
70	Knuckle Arm (Right)	DTXC6886
71	Aluminum Shock Cap Retainer	DTXC9069, DTXC9075, DTXC9077
72	Front Upper Hinge Pin (35mm)	DTXC6896
73	Front Lower Hinge Pin (50mm)	DTXC6895
74	Rear Upper Hinge Pin (22mm)	DTXC6896
75	Rear Lower Inner Hinge Pin (54mm)	DTXC6895
76	Pillow Ball	DTXC6888
77	Rear Lower Outer Hinge Pin (26mm)	DTXC6896
78	Exhaust Header Gasket	DTXC6900
79	Brake Plate w/Pad	DTXC6756
80	Spring Washer	DTXC9764, DTXC6900, DTXC7617
81	Spur Gear Hub w/One-Way Bearing	DTXC6883
82	Flywheel	DTXC7711
83	Clutch Bell (17T/22T)	DTXC7149
84	Alum Engine Mount (Left)	DTXC7617
85	Alum Engine Mount (Right)	DTXC7617
86	Brake Cam Block	DTXC6885
87	Servo Saver Bushing	DTXC8788
88	2-Speed Clutch	DTXC6884
89	Brake Cam	DTXC6754
90	Shock Shaft	DTXC9141, DTXC9075, DTXC9077
91	Servo Saver Post	DTXC8789
92	Rear Diff Shaft	DTXC7387
93	Diff Pinion Shaft	DTXC7388
94	Center Shaft	DTXC6899
95	Center Dogbone (Front, 56mm)	DTXC6901
96	Center Dogbone (Rear, 64mm)	DTXC6901
97	Dogbone (60mm)	DTXC6902
98	Center Drive Joint	DTXC6885, DTXC7498
99	Hex Drive Joint	DTXC6885
100	Wheel Shaft	DTXC6903
101	Differential Drive Joint	DTXC7497
102	Servo Saver Spring	DTXC8788
103	Brake Spring	DTXC6756
104	Throttle Spring	DTXC6757
105	Shock Spring	DTXC9076, DTXC9075, DTXC9077ng



106 Exhaust Header	DTXC6900
107 Clutch Spring	DTXC7161
108 Rod Collar	DTXC6757
109 Brake Rod	DTXC6757
110 Turnbuckle (16mm)	DTXC9649
111 Steering Turnbuckle (28mm)	DTXC9568
112 Rear Camber Rod Turnbuckle (26mm)	DTXC6892
113 Throttle Rod	DTXC6757
114 Brake Lever	DTXC6754
115 Engine Mount Plate	DTXC6894
116 Brake Disc	DTXC6755
117 Spur Gear Plate	DTXC7499
118 Exhaust Tie Wrap	DTXC6898
119 Bearing 5x11mm	DTXC1547
120 Bearing 5x10mm	DTXC1535
121 Bearing 6x12mm	DTXC1569, DTXC6818
122 Bearing 10x19mm	DTXC1705
123 Bearing 10x15mm	DTXC1595
124 Ring Gear (34T)	DTXC7398
125 Diff Pinion Gear (13T)	DTXC7388
126 Diff Gear (Small, 10T)	DTXC7387
127 Diff Gear (Large, 11T)	DTXC7497
128 Rear Body Mount	DTXC6470
129 Front Body Mount	DTXC6470
130 Spool Pin	DTXC6917
131 Pilot Shaft	DTXC6881
132 Rear Shock End	DTXC9078, DTXC9075
133 Ball End 15.2mm	DTXC9078, DTXC9077, DTXC9568
134 Camber Rod Ball End	DTXC6892
200 Body w/Decals (Orange)	DTXC6593
200 Body w/Decals (Red)	DTXC6595
200 Body w/Decals (Clear)	DTXC6596
201 Left Mirror (Orange)	DTXC9785
201 Left Mirror (Red)	DTXC9787
202 Right Mirror (Orange)	DTXC9785
202 Right Mirror (Red)	DTXC9787
204 Front Body Panel	DTXC6593, DTXC6594, DTXC6595
204 Front Body Panel (Clear)	DTXC6596
205 Rear Body Panel	DTXC6593, DTXC6594, DTXC6595
205 Rear Body Panel (Clear)	DTXC6596

HARDWARE

B 2x4mm Flat Head Self-Tapping Screw	DTXQ0201 DTXC6593, DTXC6594, DTXC6595, DTXC6596
C 2x11mm Pin	DTXC6907
D 2x10mm Pin	DTXC6908, DTXC7387
E O-Ring	DTXC9079, DTXC9075, DTXC9077
F Pillow Ball Retainer Screw	DTXC6887
G Shim 3x0.5x2.5mm	DTXC9649
H 3mm Lock Nut	DTXC6911
J 4mm Flanged Wheel Nut	DTXC6912
K 4x10mm Hex Head Screw	DTXC6906
L 3x12mm Flat Head Self-Tapping Screw	DTXQ0233
M 2x10mm Round Head Self-Tapping Screw	DTXC6470
N 3x12mm Round Head Screw	DTXQ0255
P 3x8mm Round Head Self-Tapping Screw	DTXQ0207
Q 3x10mm Round Head Self-Tapping Screw	DTXQ0207
R 3x15mm Round Head Self-Tapping Screw	DTXQ0209
T 3x28mm Round Head Self-Tapping Screw	DTXC8643, DTXC6818
U 3x8mm Pan Head Screw	DTXQ0263
V 3x10mm Pan Head Screw	DTXQ0263, DTXC8788
W 3x12mm Pan Head Screw	DTXQ0263
X 3x8mm Flat Head Screw	DTXQ0273
Y 3x10mm Flat Head Screw	DTXQ0273
Z 3x10mm Round Head Screw	DTXQ0255
AA 3x3mm Set Screw	DTXQ0301, DTXC6754, DTXC6757
BB 3x10mm Set Screw	DTXQ0301
CC 4x4mm Set Screw	DTXQ0305, DTXC6885
DD 4x3mm Set Screw	DTXQ0301, DTXC6885, DTXC7498
EE 3x8mm Hex Head Screw	DTXQ0285
FF 3x12mm Hex Head Screw	DTXQ0285, DTXC7617
GG 3x30mm Hex Head Screw	DTXQ0287, DTXC6900
HH 3x10mm Flat Head Self-Tapping Screw	DTXQ0233
JJ 2x8mm Flat Head Self-Tapping Screw	DTXC6905 DTXC7399
KK 2x8mm Round Head Self-Tapping Screw	DTXQ0201
LL 3x18mm Round Head Self-Tapping Screw	DTXQ0209, DTXC6882
MM 1.6x8mm Flat Head Self-Tapping Screw	DTXC7499
NN 3x12mm Round Head Self-Tapping Screw	DTXQ0207
PP 3x6x.3mm Shim	DTXC6909
QQ 5x8x.3mm Shim	DTXC6918
RR 3x5x1.5mm Shim	DTXC6892, DTXC9075, DTXC9077, DTXC9649
TT 2.5mm E-Clip	DTXQ0523, DTXC7388, DTXC7497, DTXC9075, DTXC9077,
UU 4mm E-Clip	DTXQ0525, DTXC8789
VV 7mm E-Clip	DTXQ0528
WW 13mm C-Clip	DTXC6883
XX Body Clip	DTXC6772, DTXC8410
YY Ball 5.8x5.5mm	DTXC9568, DTXC9649
ZZ Ball 6.8x6mm	DTXC6892, DTXC9075, DTXC9077
AAA 4mm Nut	DTXQ0403, DTXC9785 DTXC9786, DTXC9787

