

**DURATRAX**<sup>®</sup>

# **VENDETTA**<sup>™</sup>



**ASSEMBLY AND OPERATION MANUAL**

[www.duratrax.com](http://www.duratrax.com)

# ITEMS INCLUDED

The following items are included in the box.

- Chassis
- Body
- Decal Sheet (Not Shown)
- Transmitter
- Transmitter Antenna
- Transmitter Flag (Not Shown)
- Receiver Antenna Tube with Antenna Cap (Not Shown)
- Shock Spring Clips (Not Shown)
- "AA" Batteries (Qty 8)
- Instruction Manual (Not Shown)
- Exploded View/Parts Listing (Not Shown)
- Extra Servo Saver Adapters for Hitec, JR (Not Shown)



# YOU WILL NEED



PHILLIPS HEAD SCREWDRIVER  
DTXR0124

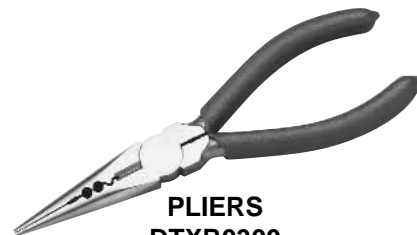

PLIERS  
DTXR0300

# THINGS TO KNOW

## SAFETY PRECAUTIONS

When the safety precautions are followed, the Vendetta will provide years of enjoyment. Use care and good sense at all times when operating this radio controlled buggy. Failure to use this vehicle in a safe, sensible manner can result in injury or damage to property. You and you alone must insure that the instructions are carefully followed and all safety precautions are obeyed.

- Do not operate the Vendetta near people. Spectators should be behind the driver or at a safe distance away from the vehicle.
- Water can cause the electronics to short out and can cause permanent damage.
- Always turn on the transmitter before turning on the receiver.
- Fully extend the transmitter antenna before operating your vehicle.
- Before turning on your radio system, check to make sure that no one else is running on the same frequency.

## CHARGING PRECAUTIONS

- Never leave the charger unattended during charging.
- If the battery or the charger become hot at any time, disconnect the battery from the charger immediately! Failure to do so could cause permanent damage to the charger and battery and may cause bodily harm.
- Do not allow water or moisture in contact with the charger.
- Do not place the charger on or near a flammable object during use.
- Only charge 6-cell, 2/3A-size batteries.
- Keep out of the reach of children.
- Avoid running the buggy in cold weather. The plastic and metal parts can become brittle at low temperatures. In addition, grease and oil become thick, causing premature wear and poor performance.

## SPECIFICATION AND DESCRIPTION CHANGES

All pictures, descriptions and specifications found in this instruction manual are subject to change without notice. DuraTrax maintains no responsibility for inadvertent errors in this manual. Visit [www.duratrax.com](http://www.duratrax.com) for the latest updates and information for your model.

## WARRANTY

- DuraTrax® guarantees this kit to be free from defects in both material and workmanship at the date of purchase. DuraTrax will warranty this kit for 90 days after the purchase date. DuraTrax will repair or replace, at no charge, the incorrectly made part.
- Make sure you save the receipt or invoice you were given when you bought your model! It is your proof of purchase and we must see it before we can honor the warranty. Further, DuraTrax reserves the right to change or modify this warranty without notice.
- In that DuraTrax has no control over the final user assembly or material used for final user assembly, no liability shall be assumed nor accepted for any damage resulting from the use by the user of the final user-assembled product. By the act of using the user-assembled product, the user accepts all resulting liability.

To return your Vendetta for repairs covered under warranty, you should send your buggy to:

Hobby Services  
3002 N. Apollo Drive Suite 1  
Champaign, Illinois 61822  
Attn: Service Department  
Phone: (217) 398-0007 9:00 am-5:00 pm  
Central Time M-F  
E-mail: [hobbyservices@hobbico.com](mailto:hobbyservices@hobbico.com)  
[www.hobbyservices.com](http://www.hobbyservices.com)

**If the buyer is not prepared to accept the liability associated with the use of this product, the buyer is advised to return this kit immediately in new and unused condition to the place of purchase.**

## STRESS-TECH™ PARTS GUARANTEE

We have engineered the Vendetta to take the rough and tumble abuse that makes R/C buggies fun. We are so confident of the quality and durability of the Stress-Tech plastic parts that we will replace any Stress-Tech plastic part you break during the first 12 months you own the buggy. Just send in the part to us and we will send you a **FREE** replacement. Please see the Vendetta parts list for the items covered under the Stress-Tech guarantee.

To receive your free replacement part please send the following to the Hobby Services address listed under the warranty on the left.

- 1. The broken part must be included.
- 2. The part number and description of the broken part.
- 3. Copy of your dated invoice or purchase receipt.
- 4. Your name, phone number and shipping address.

## REPAIR SERVICE

**Repair service is available anytime.**

- After the 90 day warranty, you can still have your Vendetta repaired for a small charge by the experts at DuraTrax's authorized repair facility, Hobby Services.
- To speed up the repair process, please follow the instructions listed below.
  - 1. Under most circumstances return the **ENTIRE** vehicle. The exception would be sending in a Stress-Tech part. See the instructions under the Stress-Tech Guarantee.
  - 2. Make sure the transmitter is turned off, and all of the batteries are removed.
  - 3. Send written instructions which include: a list of all items returned, a **THOROUGH** explanation of the problem, the service needed and your phone number during the day. If you expect the repair to be covered under warranty, be sure to include a proof of date of purchase (your store receipt or purchase invoice).

# FINISHING THE VENDETTA

## TRANSMITTER PREPARATION

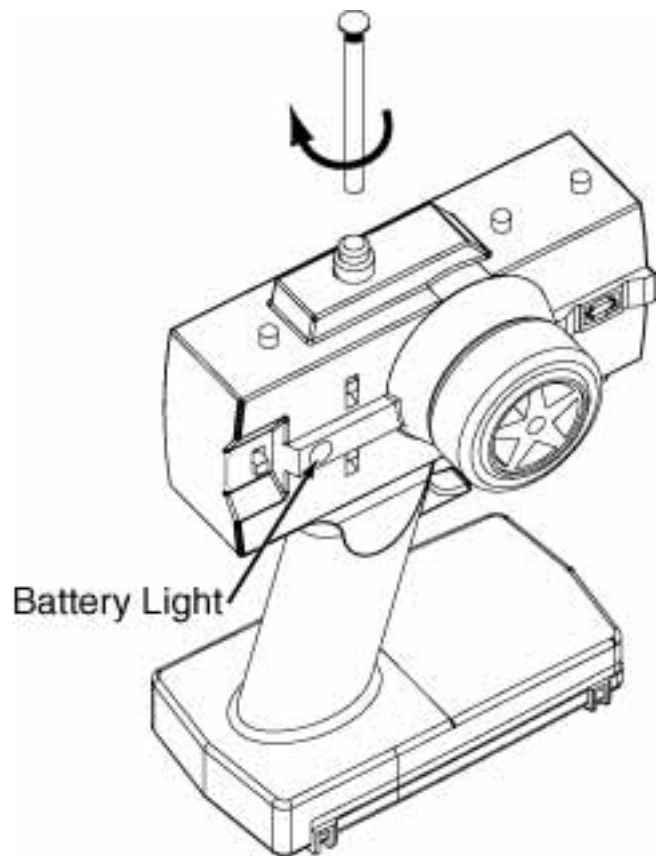
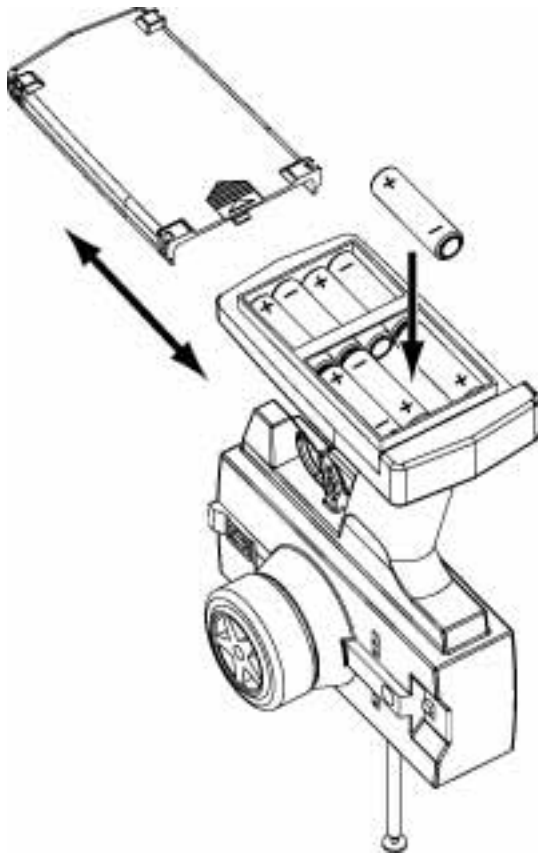

- Install eight “AA” batteries into transmitter, making sure the polarity is correct.
- Insert the antenna into the top of the transmitter and tighten.
- Turn the transmitter on and check the battery light. If the red light glows steady, turn off the transmitter. If the red light blinks, the batteries are low and should be replaced.

## RECEIVER BATTERY INSTALLATION

- Plug in the included wall charger.
- Attach the included 6-cell (7.2V) battery to the charger.
- When the battery is fully discharged, it should take 3 hours to fully charge. A half-charged battery, 1-1/2 hours, etc.
- **CAUTION:** If the battery becomes hot to the touch, disconnect it from the charger.

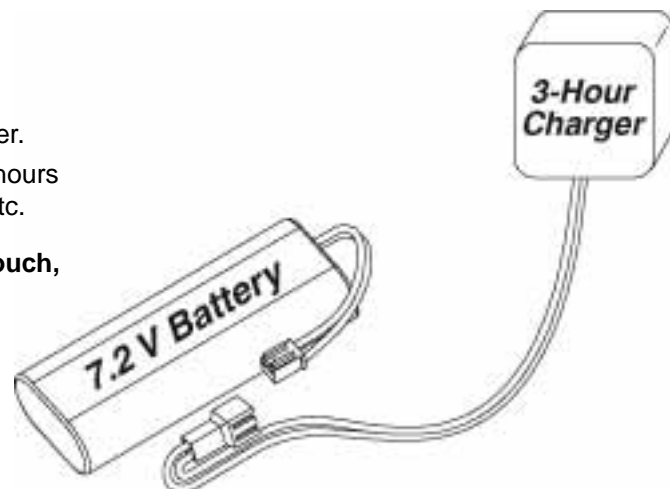

### RECEIVER ANTENNA INSTALLATION

- Route the receiver antenna wire through the receiver antenna tube.
- Insert the antenna tube into the molded antenna mount on the battery strap.
- Install the antenna tube cap onto the top of the antenna tube.
- DO NOT cut or coil the receiver antenna wire.

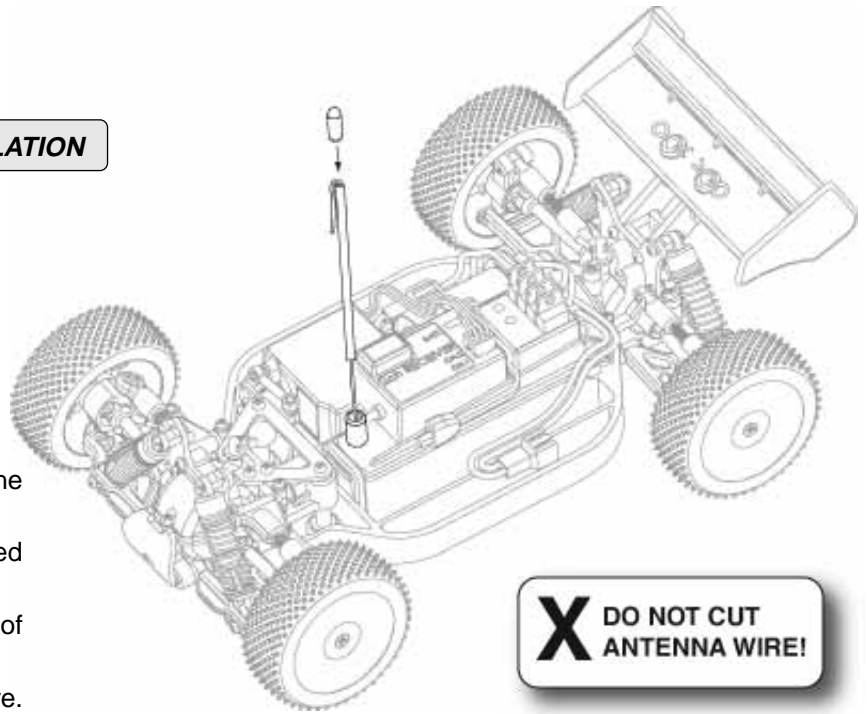

### 6-CELL BATTERY INSTALLATION

- Remove the body clip from the battery strap post.
- Remove the battery strap.
- Install the included 7.2V battery into the chassis.
- Reinstall the battery strap and secure it in place with the body clip.
- Check that the ESC is "OFF," and then plug the battery into the ESC.

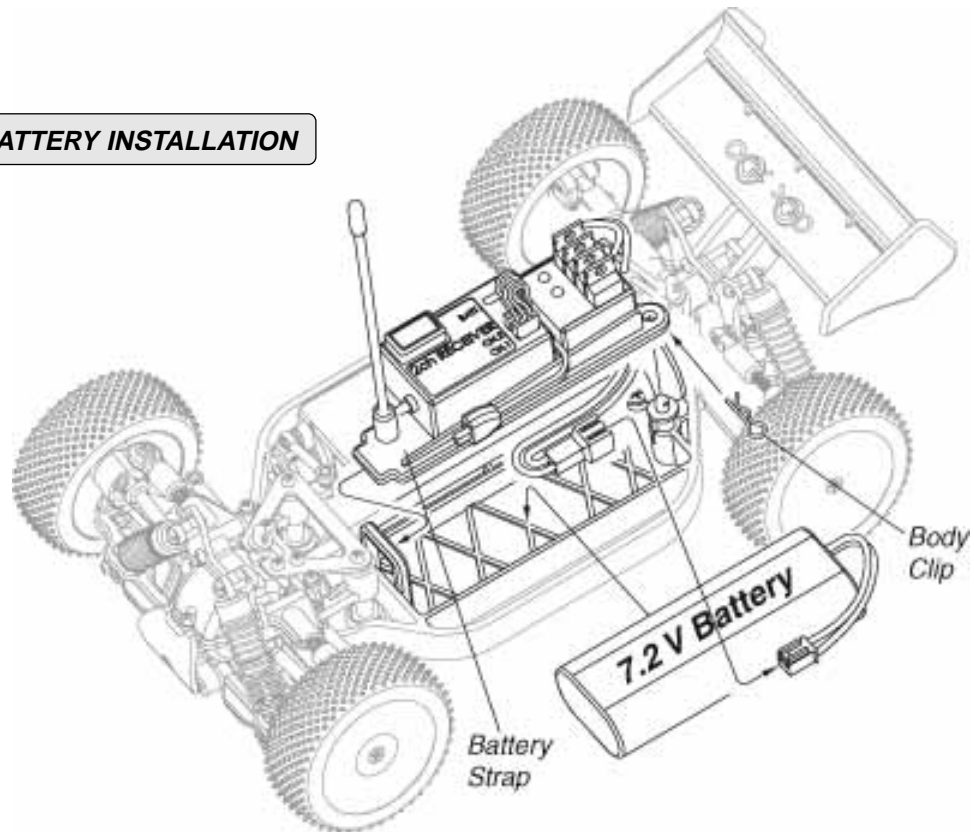

## RADIO SYSTEM CHECK

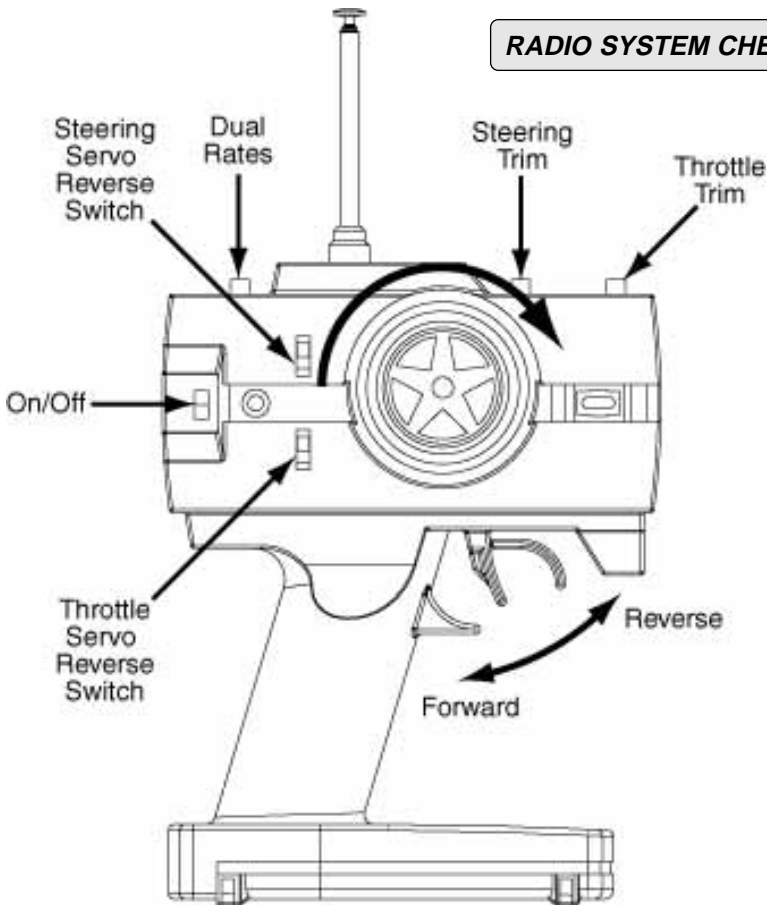

**! CHECK THE RADIO SYSTEM FOR PROPER FUNCTION BEFORE EACH RUN**

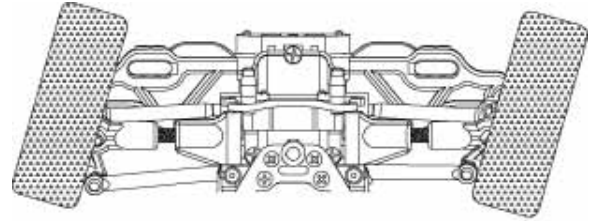

WHEELS TURN RIGHT

- Turn the transmitter on. Then turn the receiver on.
- Turn the transmitter wheel to the right—the front wheels should turn to the right. If not, move the steering servo reverse switch.
- When running, adjust the steering trim so the buggy tracks straight.
- Gently pull back on the throttle trigger. The Vendetta should slowly move forward. If the buggy goes in reverse, move the throttle reversing switch on the transmitter. The throttle trim knob may also need to be adjusted to find neutral.

## ESC SETUP

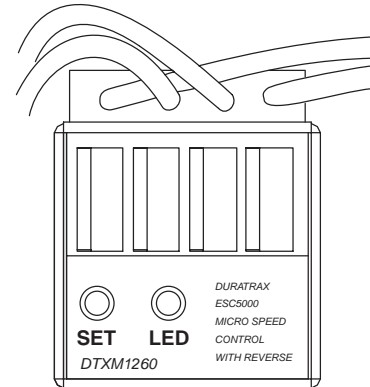

- Center the throttle trim knob on the transmitter.
- Connect the battery pack to the ESC, turn on the Tx, then the ESC.
- Press and hold the “set” button until both LEDs are flashing, then release the button.
- NEUTRAL POINT: Leave the throttle trigger in the neutral position. Press the setup button once; the green LED will flash.
- FULL THROTTLE: Move the throttle trigger to full throttle and press the button once until the red LED illuminates (motor will not operate in set up mode).
- FULL REVERSE: Move the throttle trigger to full reverse and press the button once – the red LED will stop flashing. Release the throttle trigger; the ESC is now ready to operate with your system. If the motor operates in reverse when applying forward throttle, the throttle reversing switch on the Tx must be moved to the opposite position.

## BODY INSTALLATION

- Decal the body to your liking. Use the photos on the box as a reference.
- Install the body onto the chassis using two body clips.

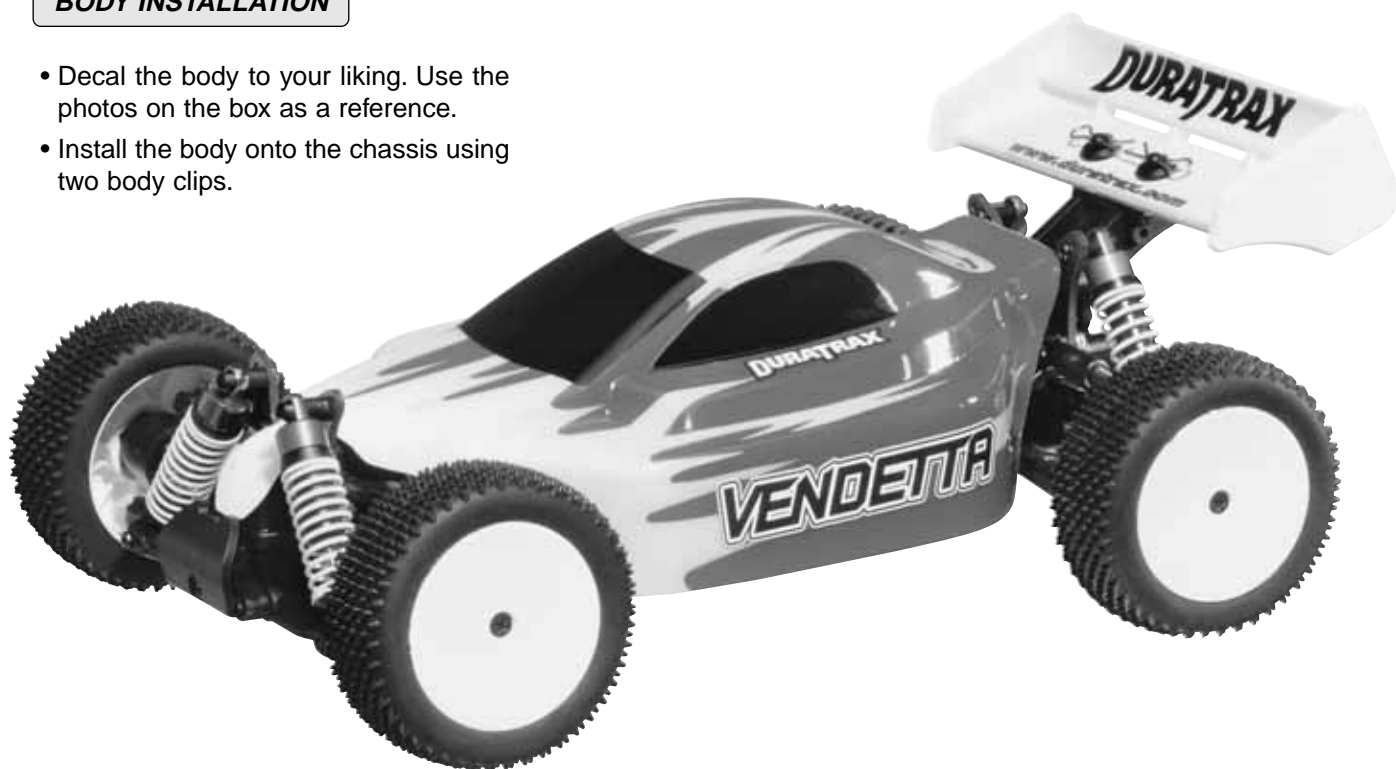

## MAINTENANCE TIPS

### BEFORE EACH RUN

- **IMPORTANT:** Check to make sure that all screws are tight. Always use threadlock (DTXR2010) on screws going into metal.
- Before running always check the condition of your radio system batteries and replace/recharge if necessary.
- Check to make sure that all of the moving parts of the Vendetta move freely and do not bind.
- Before running, turn on the radio and make sure the servos move easily and in the proper direction.
- Check for broken or damaged parts. Replace any broken or damaged parts before running the Vendetta. Running of the Vendetta with broken or damaged parts could result in damage to other parts.
- Check to make sure that all wires are properly connected.
- Check that the ESC and receiver are properly secured to the chassis.



### AFTER EACH RUN

- Clean any large globs of dirt or debris from the chassis and moving parts.
- Check for any broken or damaged parts. This way parts may be replaced before the next run.
- Disconnect and remove the battery from the chassis.
- Check for any broken or damaged parts. This way parts may be replaced before the next run.

### AFTER EVERY 10 RUNS

- Check to make sure that the bearings are free of dirt and debris, and roll smoothly.
- Check the shocks for oil leakage. Inspect the shaft and O-rings for wear and damage. Replace if necessary. (A shock shaft with scratches you can feel with a fingernail should be replaced.)
- Check the tires to make sure they are still properly glued to the wheels.

# TUNING GUIDE

When tuning the Vendetta make sure that you have equal lengths from one side to the other on the shocks and upper rods. Also, make sure to have the shock pre-load adjusters at the same setting from left to right. They do not have to be the same front to rear.

## RIDE HEIGHT ADJUSTMENT

The ride height of the Vendetta is easily adjusted by using the included pre-load spacers. To increase the ride height of the Vendetta, install a pre-load spacer onto each of the shock bodies between the spring and the shock cap. The more pre-load clips you install, the more ride height you will achieve. Make sure you install the same amount of pre-load clips from side to side. To lower the ride height of the Vendetta, remove the desired amount of pre-load spacers from the shocks. **TIP:** Rough, rocky surfaces require higher ride height; flat, smooth surfaces allow a lower ride height.

## FRONT SHOCK ADJUSTMENT

Moving the tops of the shocks out will increase steering, resulting in quicker reaction. Moving the tops of the shocks in will result in slower steering reaction, but will be smoother over bumps. Mounting the bottoms of the shocks in the inside hole will give more slow-speed steering but will take away some high-speed steering.

## REAR SHOCK ADJUSTMENT

Moving the tops of the shocks in will result in more traction in the corners and smoother handling over bumps. Moving the tops of the shocks out will give the buggy more steering and better ability to handle the large jumps.

## SHOCK SPRINGS

DuraTrax offers two different optional shock springs: Soft (white) and Heavy (green), the Vendetta comes stock with Medium springs (yellow). For rutted tracks with small jumps, a soft spring should be used. For tracks with large jumps, a heavy spring should be used to help prevent chassis slap.

## SHOCK OIL

The Vendetta comes stock with 25 weight oil in the shocks. The handling of the buggy can be tuned by changing the shock oil to either heavier (bigger number) or lighter (lower number.) By putting heavier oil in the shocks, the buggy will have less chassis roll and become less responsive. Putting lighter oil in the shocks will cause the buggy to be more responsive and have more chassis roll. For smooth, flat surfaces, a thicker oil would be best. For surfaces that are rough or have jumps, a lighter oil would be best.

## PINIONS

The Vendetta comes stock with the 16 tooth pinion. To obtain higher top speeds you can install a larger pinion gear onto the motor. This will, however, decrease your acceleration and run time. **TIP:** Smaller pinion equals more torque, less top speed. Larger pinion equals more top speed, less torque.

## CAMBER

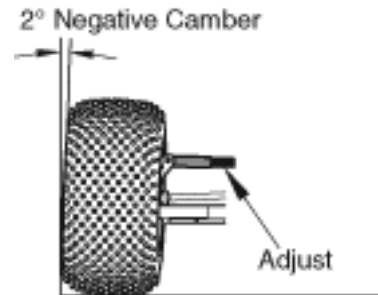

Camber refers to the angle at which the tire and wheel ride in relation to the ground when viewed from the front or rear. Negative camber is when the wheels lean inward and positive camber is when the wheels lean outward. Usually adding a small amount of negative camber (0° to -2°) will increase traction. However, adding too much camber will decrease traction. The objective is to keep as much of the tire as possible in contact with the running surface. Never put in positive camber. Make sure that both sides are equal.

Use the DuraTrax Pit Tech™ Camber Gauge (DTXR1145) to accurately set up your Vendetta.



## TOE-IN AND TOE-OUT

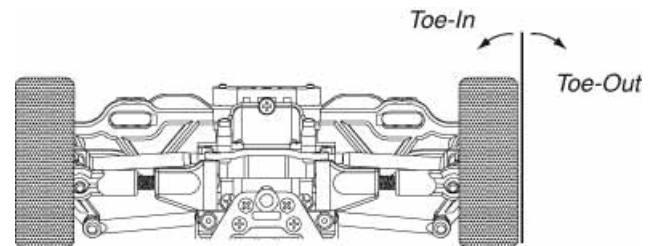

Toe-in is when the fronts of the tires point towards each other. Toe-in increases stability during acceleration and high speed. However, toe-in also decreases steering when entering a corner. Toe-out will increase steering into corners, but will decrease the overall stability during acceleration. The front typically is set-up with 0 to -2 degrees of toe-in. Toe-out is when the fronts of the tires point away from each other.



# MAINTENANCE GUIDE

## 1 Gear Differential For front and rear

The following section is provided to help you with maintenance and repairs to your Vendetta. Pay extra attention to the notes and tips for proper assembly.

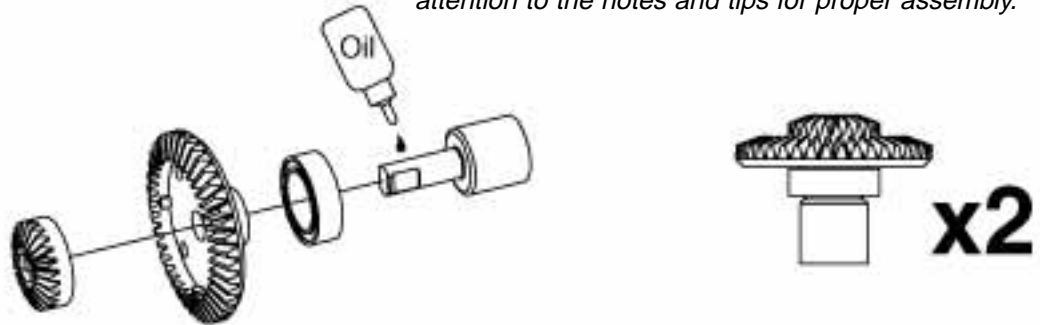

## 2

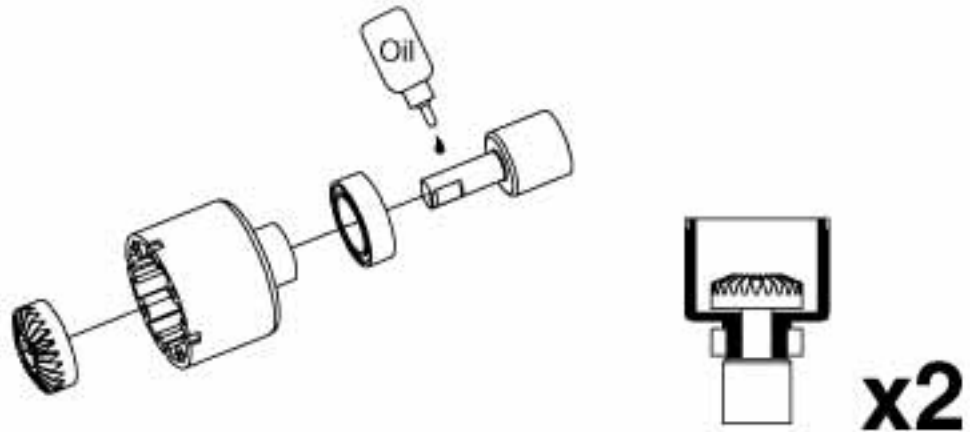

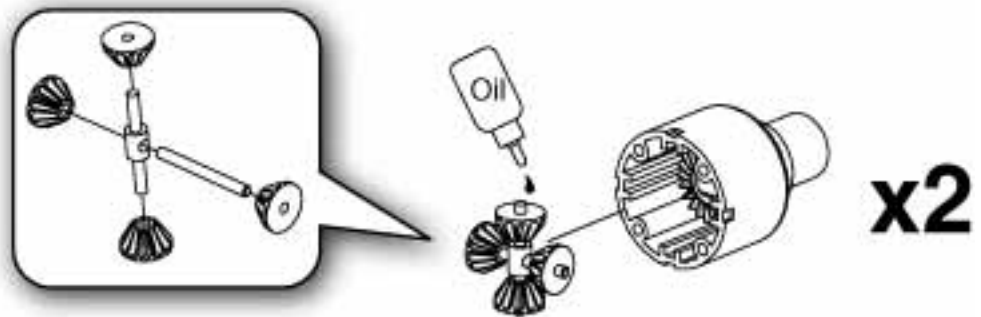
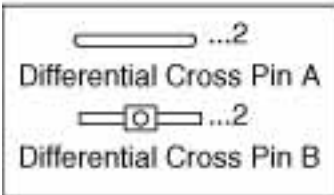

## 3

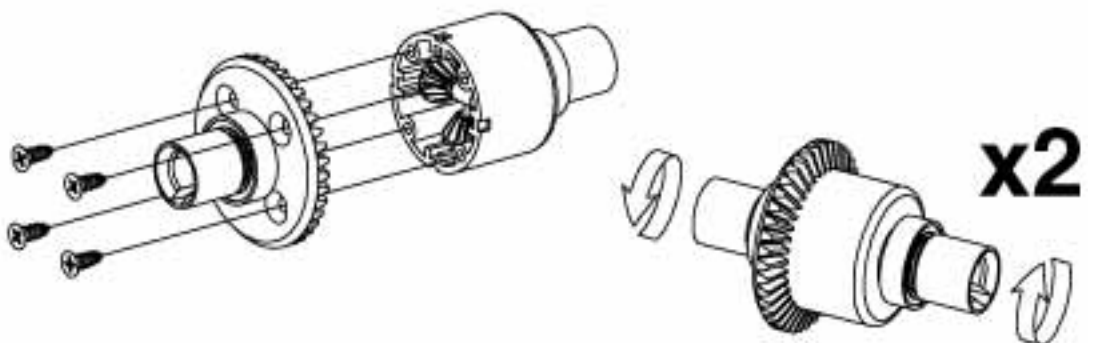
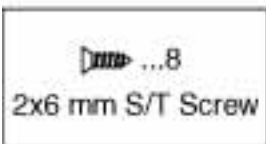

## 4



5

-  ...1  
6x10 mm Ball Bearing
-  ...2  
8x12 mm Ball Bearing
-  ...1  
3 mm E-Clip
-  ...1  
2 mm Drive Shaft Pin

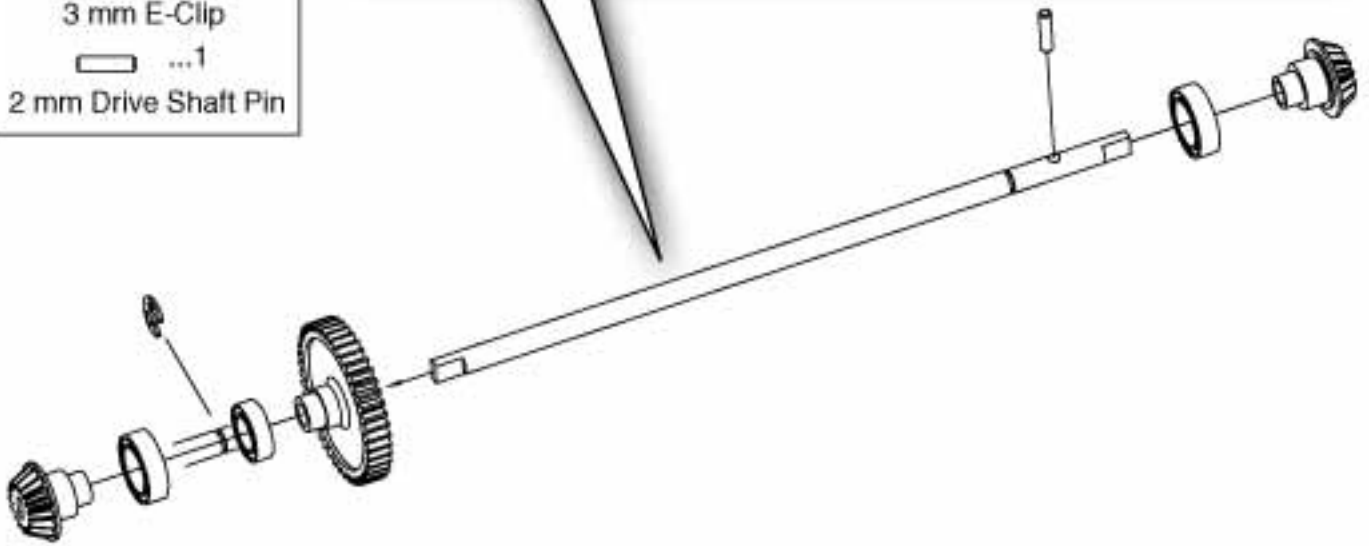
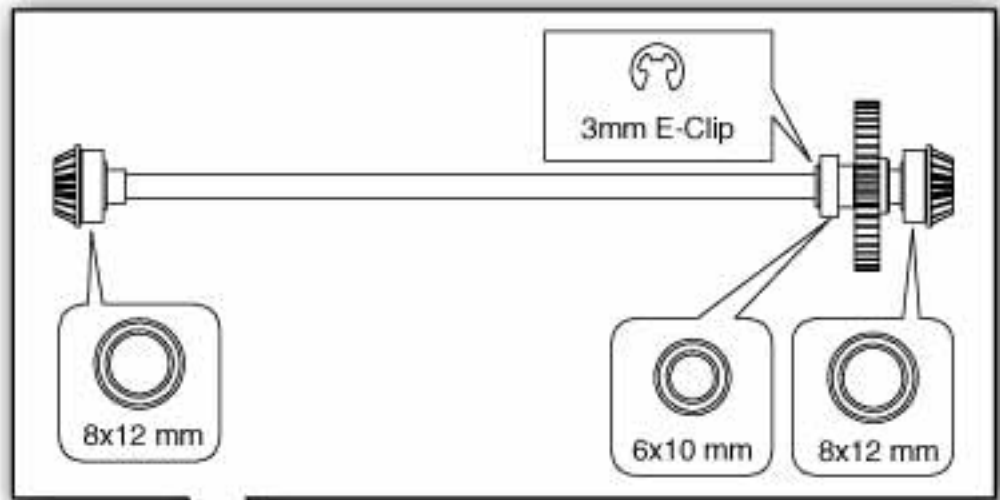

6

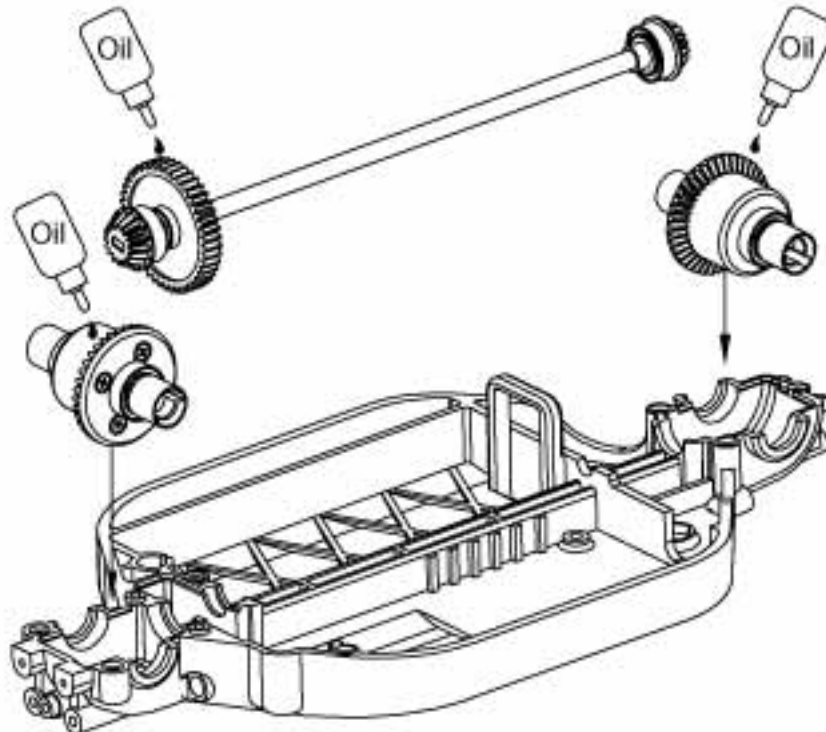

7

 ...5  
2.6x8 mm S/T Screw

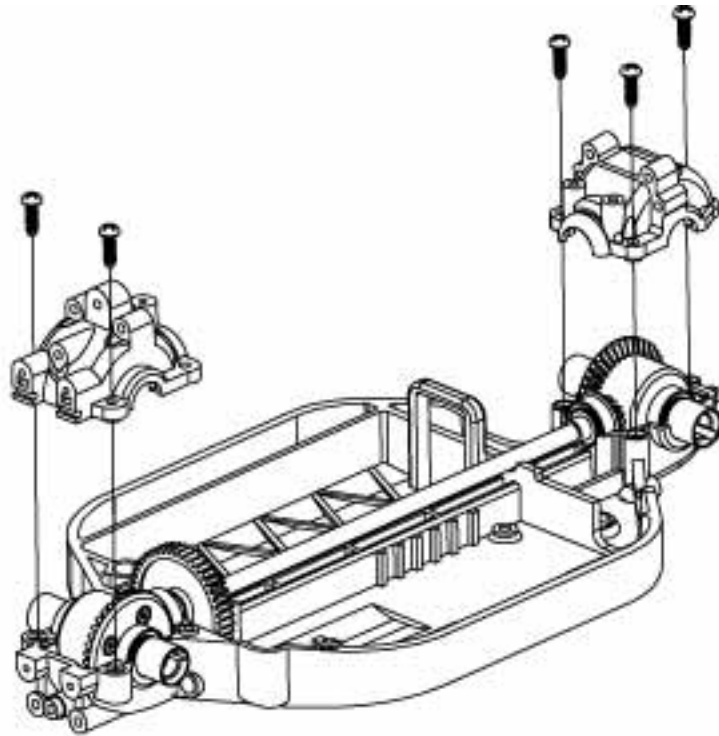

8

 ...2  
2.6x6 mm Screw

When using optional pinion gear set,  
adjust motor position.

13T 19T 11T 16T 21T

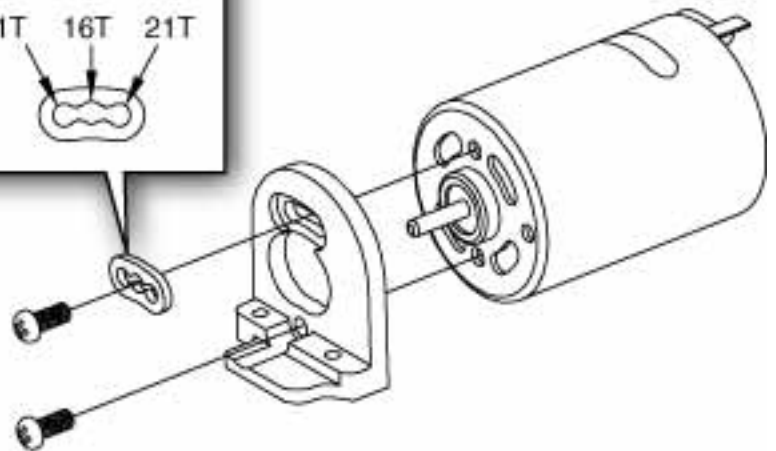

9

 ...1  
3x3 mm Set Screw

 ...1  
16T Pinion

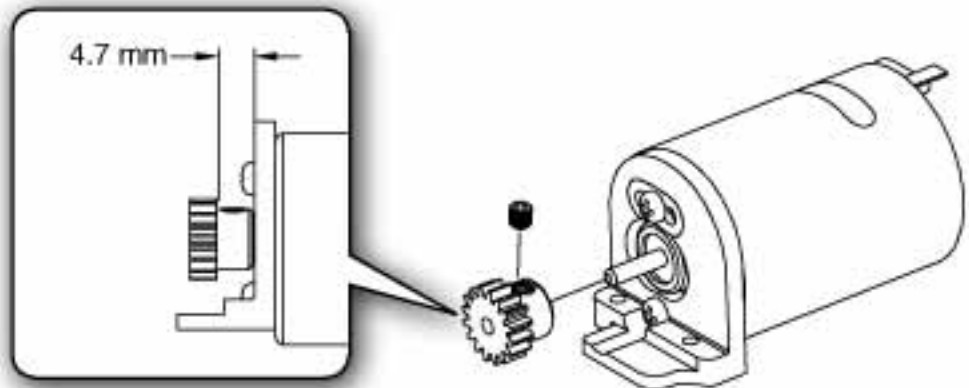

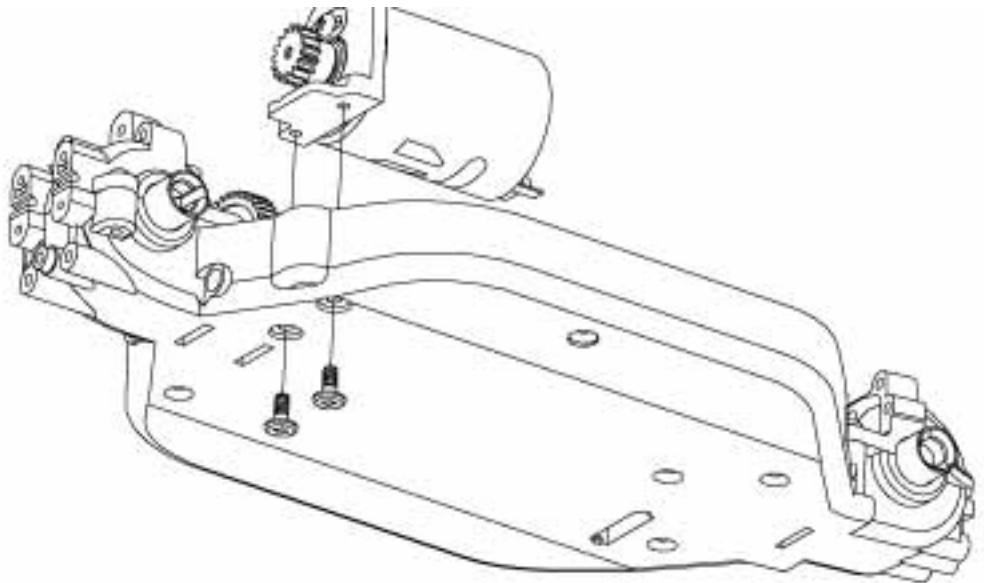

10

 ...2  
2.6x6 mm Motor  
Mount Screw



11

 ...2  
2.6x8 mm S/T Screw

 ...2  
2.6x12 mm S/T Screw

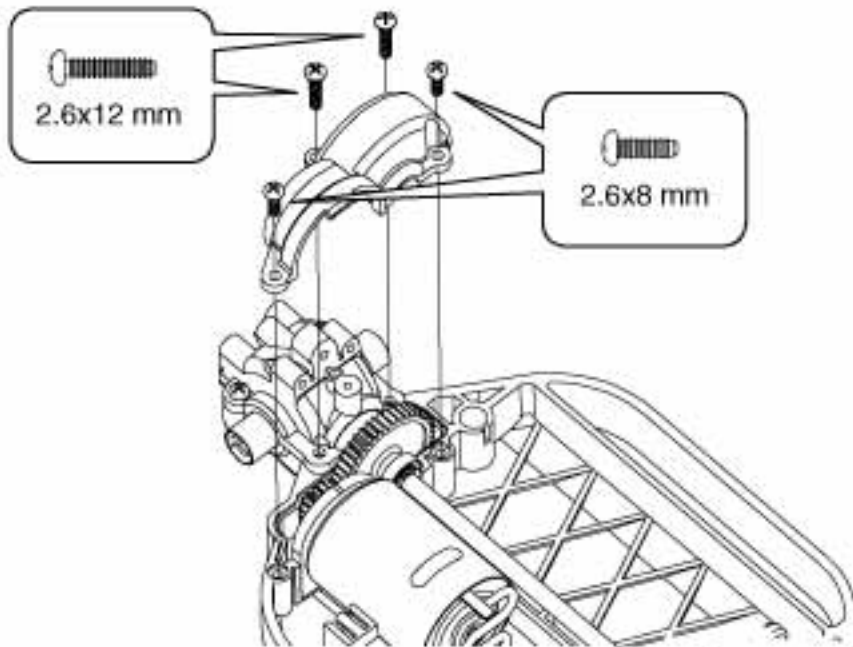

12

 ...1  
2.6x10 mm S/T Screw

 ...2  
2.6x8 mm Screw

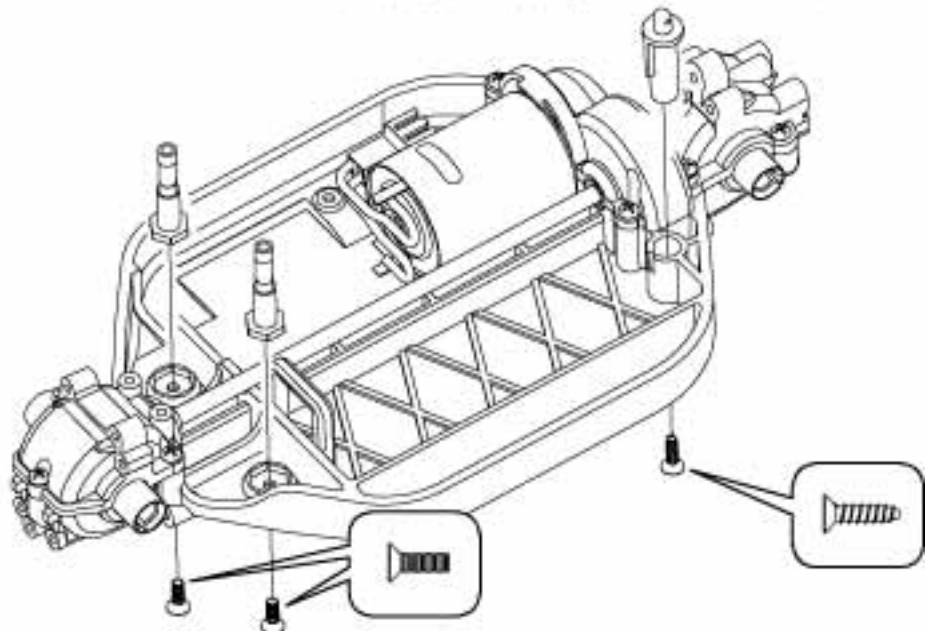

13

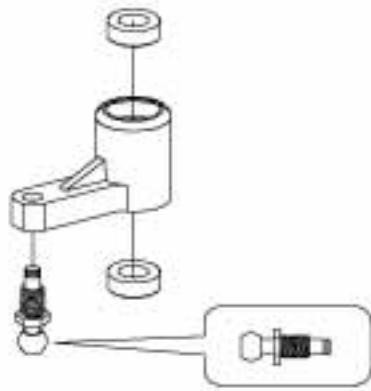

14

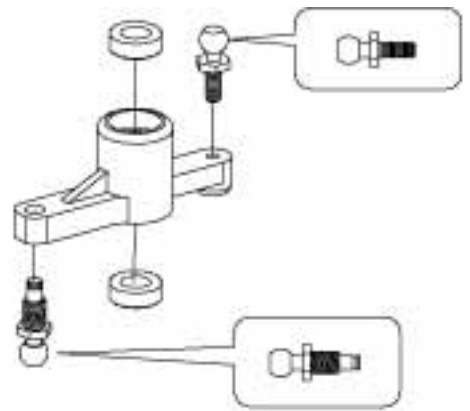

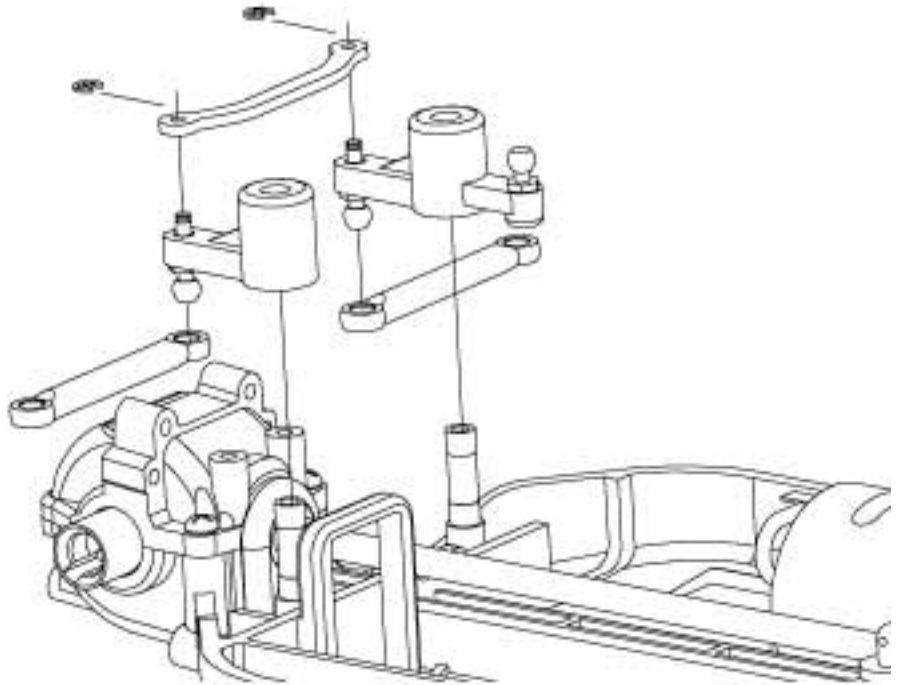

15

 ...2  
1.5 mm E-Clip



16

 ...1  
2x6 mm S/T Screw

 ...2  
2.6x6 mm Screw

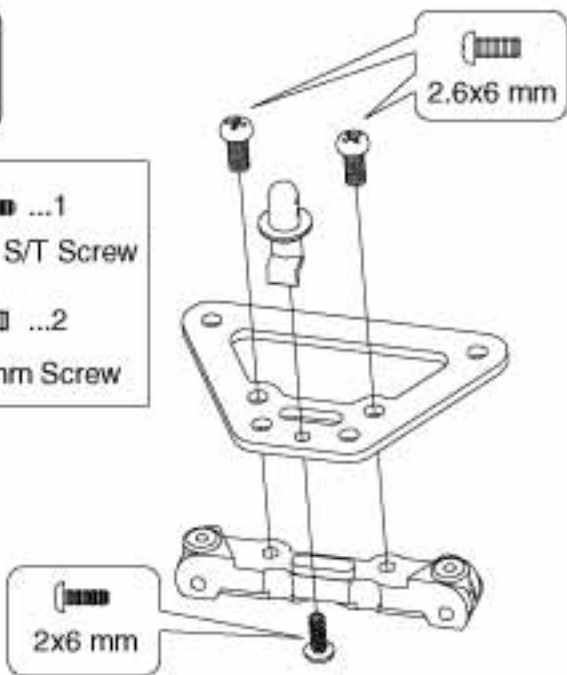

17

 ...4  
2.6x6 mm Screw

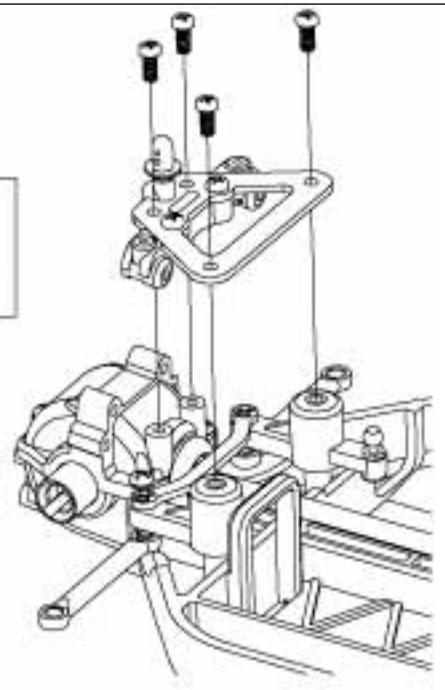

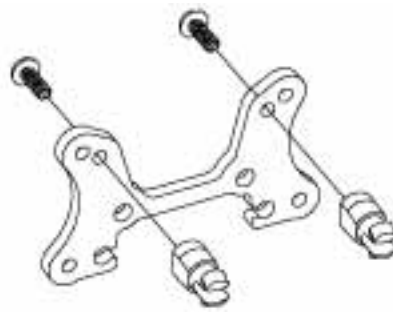

18

 ...2  
2x6 mm S/T Screw



19

 ...4  
2.6x8 mm S/T Screw  
 ...2  
2.6x10 mm S/T Screw

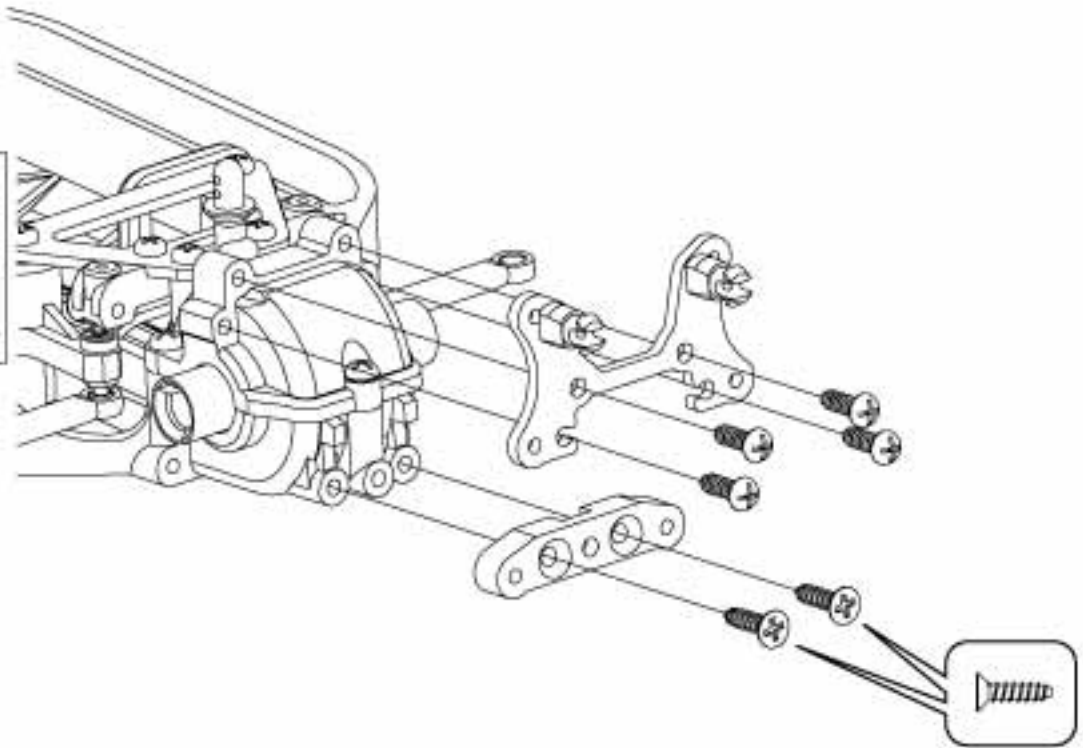

20

 ...2  
2x6 mm S/T Screw

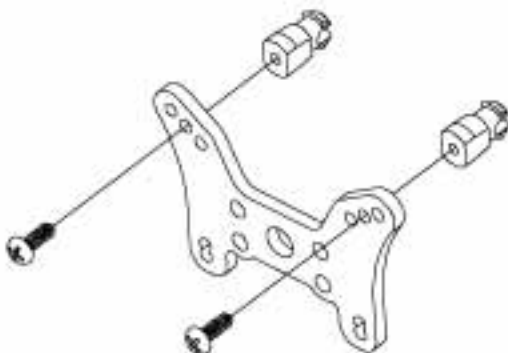

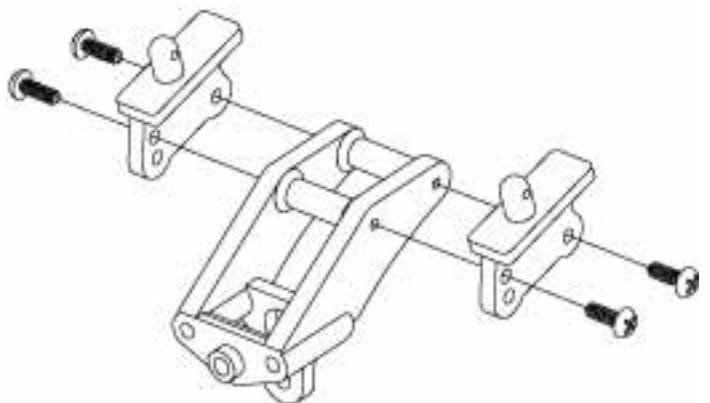

21

 ...4  
2x6 mm S/T Screw



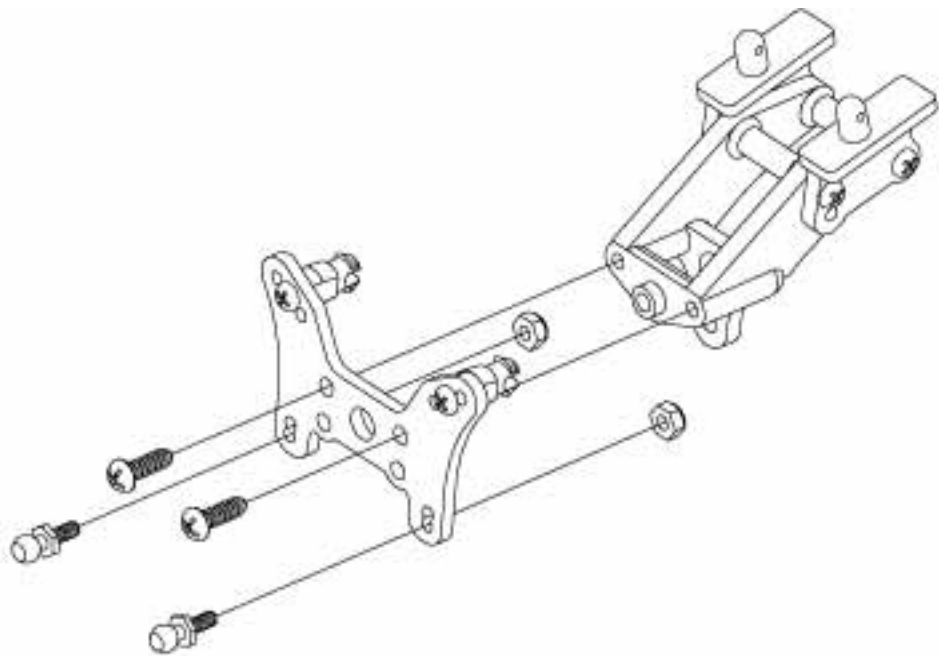

22

-  ...2  
2 mm Locknut
-  ...2  
2.6x8 mm S/T Screw
-  ...2



23

-  ...3  
2.6x8 mm S/T Screw
-  ...1  
2.6x12 mm S/T Screw

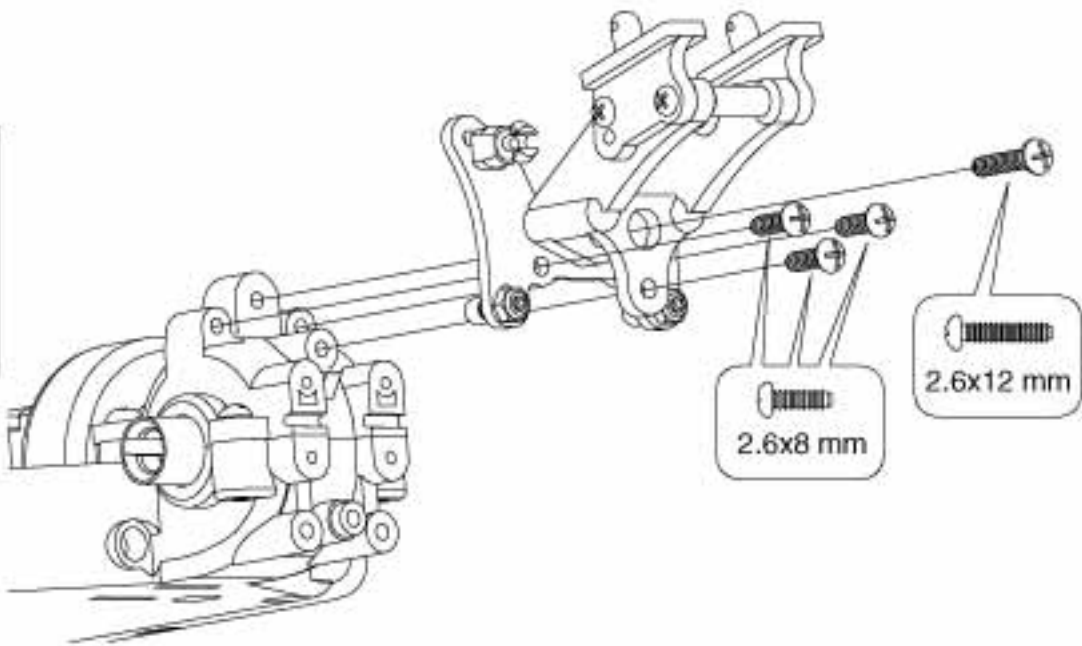

24

-  ...2  
6x10 mm Ball Bearing

**Left**



25

-  ...2  
6x10 mm Ball Bearing

**Right**



26

4x20 mm Threaded Shaft

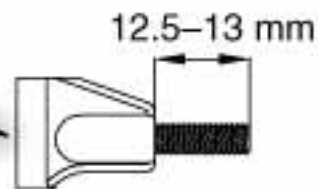

x2

27

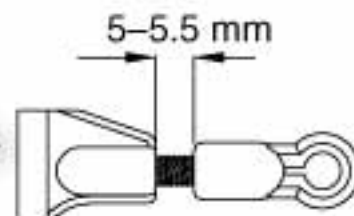
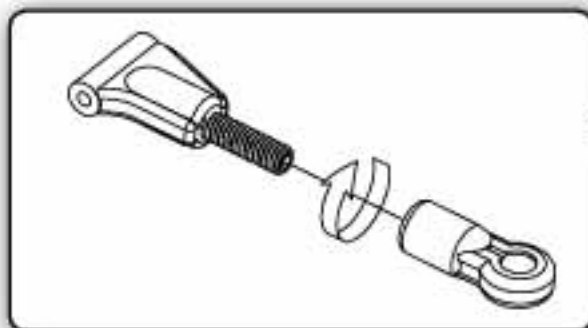

x2

28

Right



29

Left

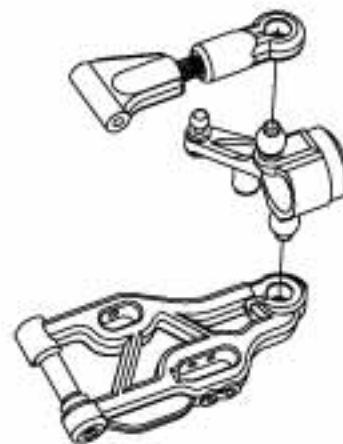

30

2 mm Pin

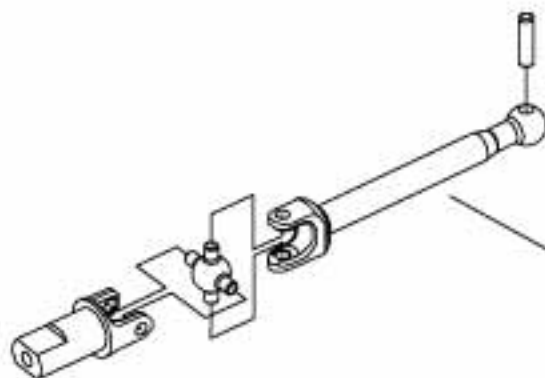

x4



31

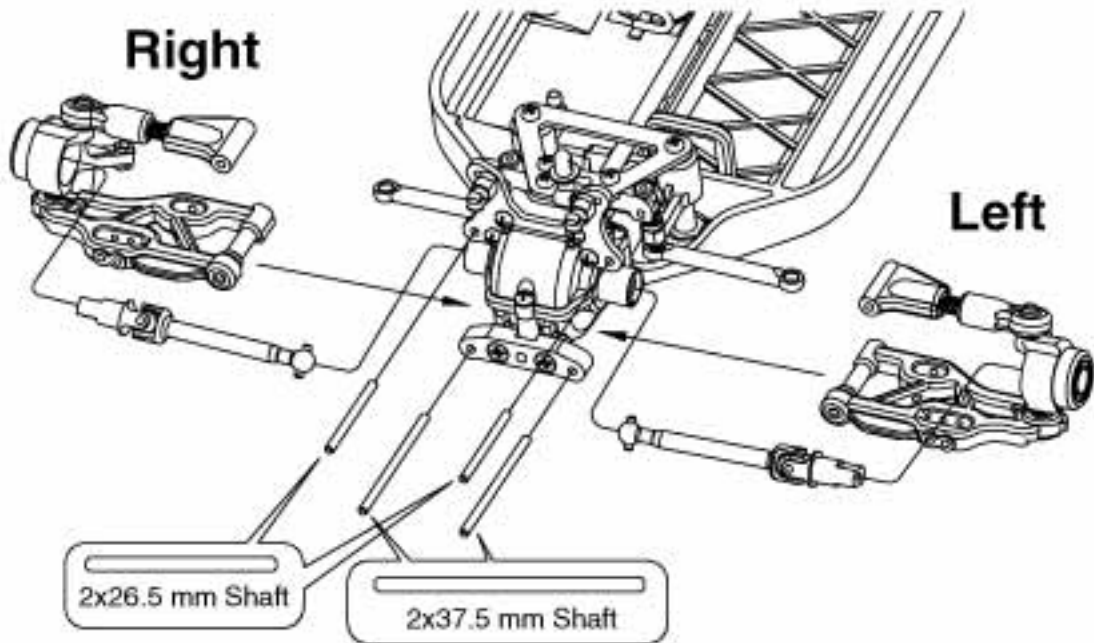

32

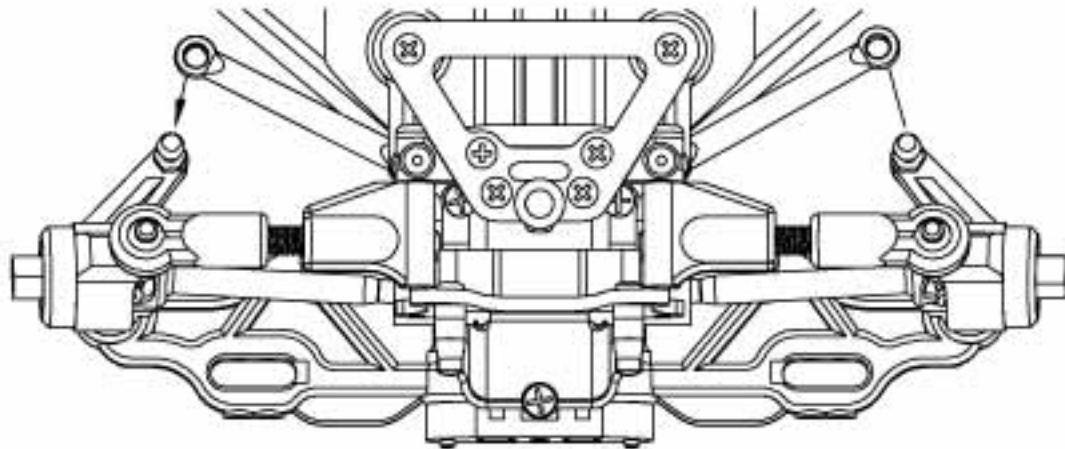

33

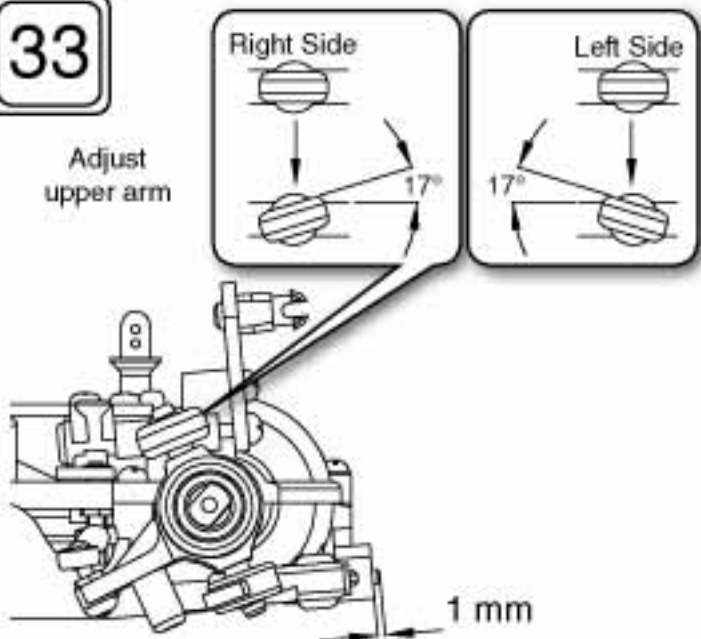

34

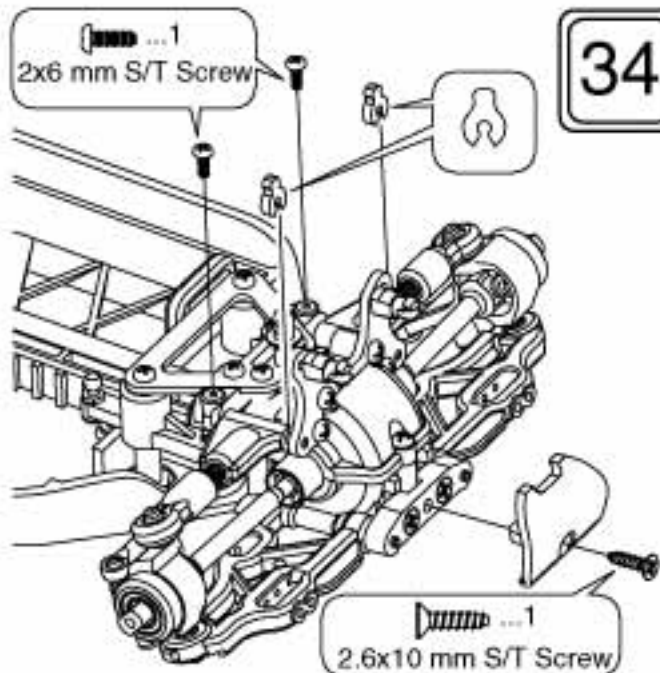

35

3x20 mm  
Threaded Shaft

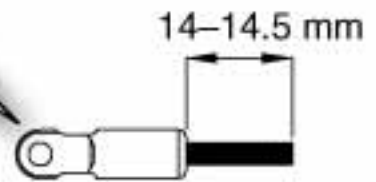

x2

36

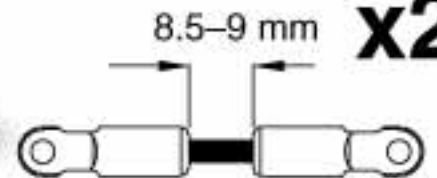
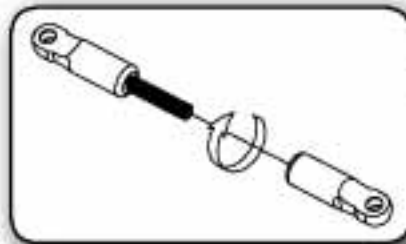

x2

37



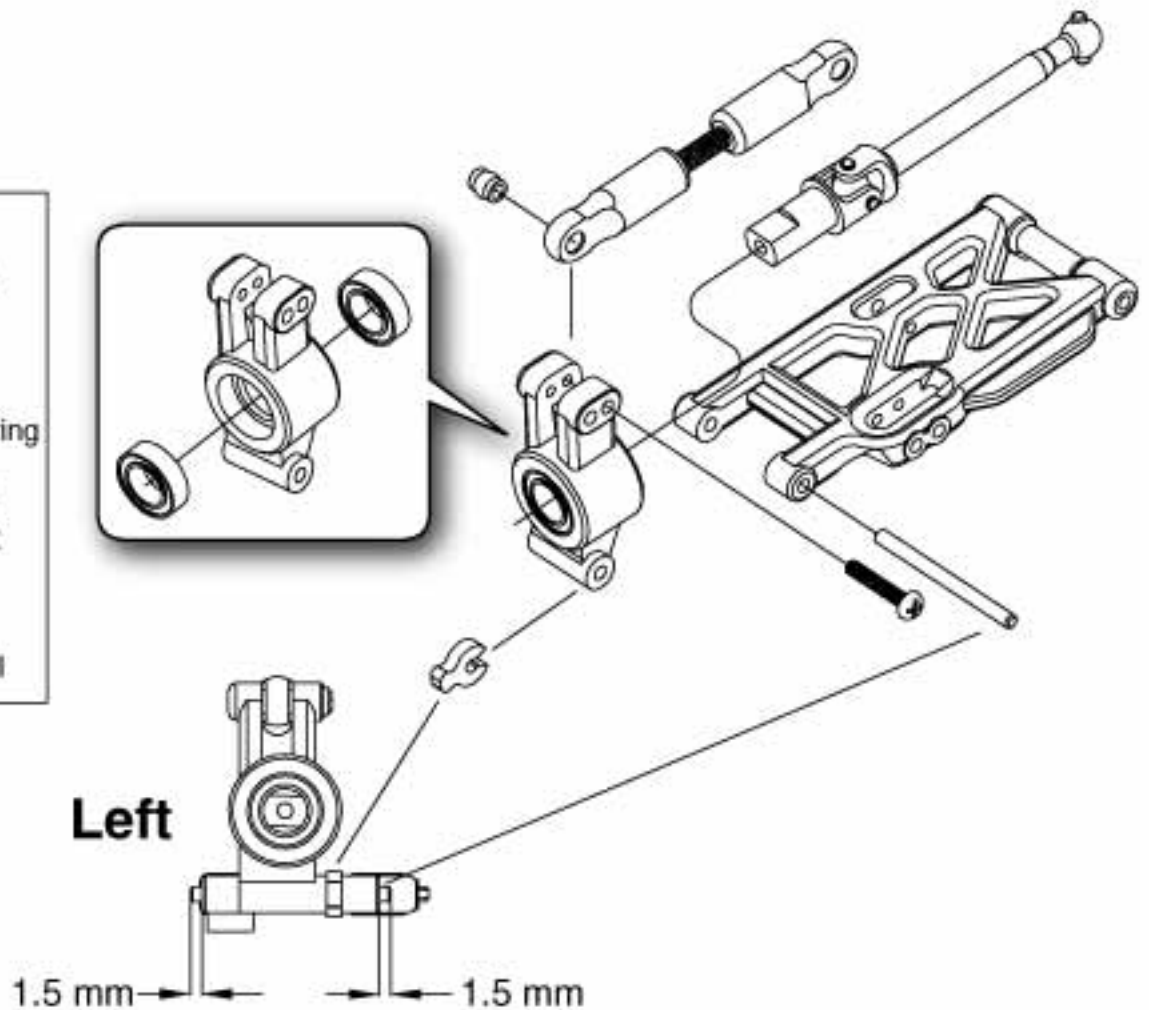
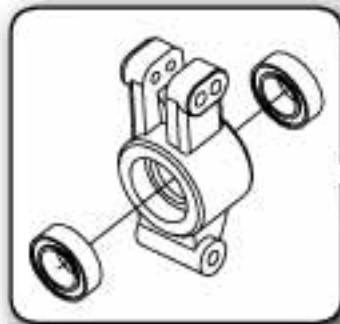

2x12 mm Screw  
6x10 mm Ball Bearing  
2x26.5 mm Shaft  
3.8 mm Pivot Ball



Left

1.5 mm 1.5 mm

38

-  ...1  
2x12 mm Screw
-  ...2  
6x10 mm Ball Bearing
-  2x26.5 mm Shaft
-  3.8 mm Pivot Ball

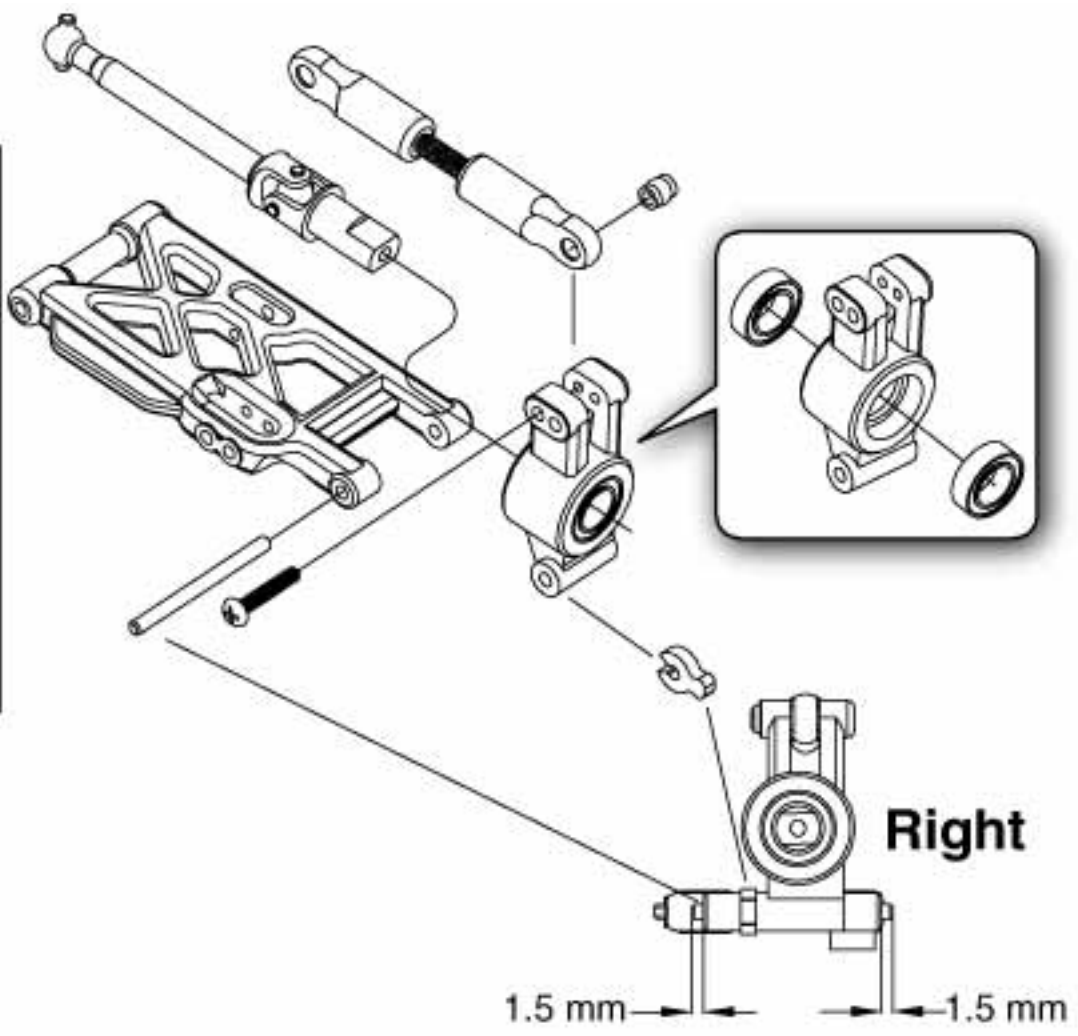

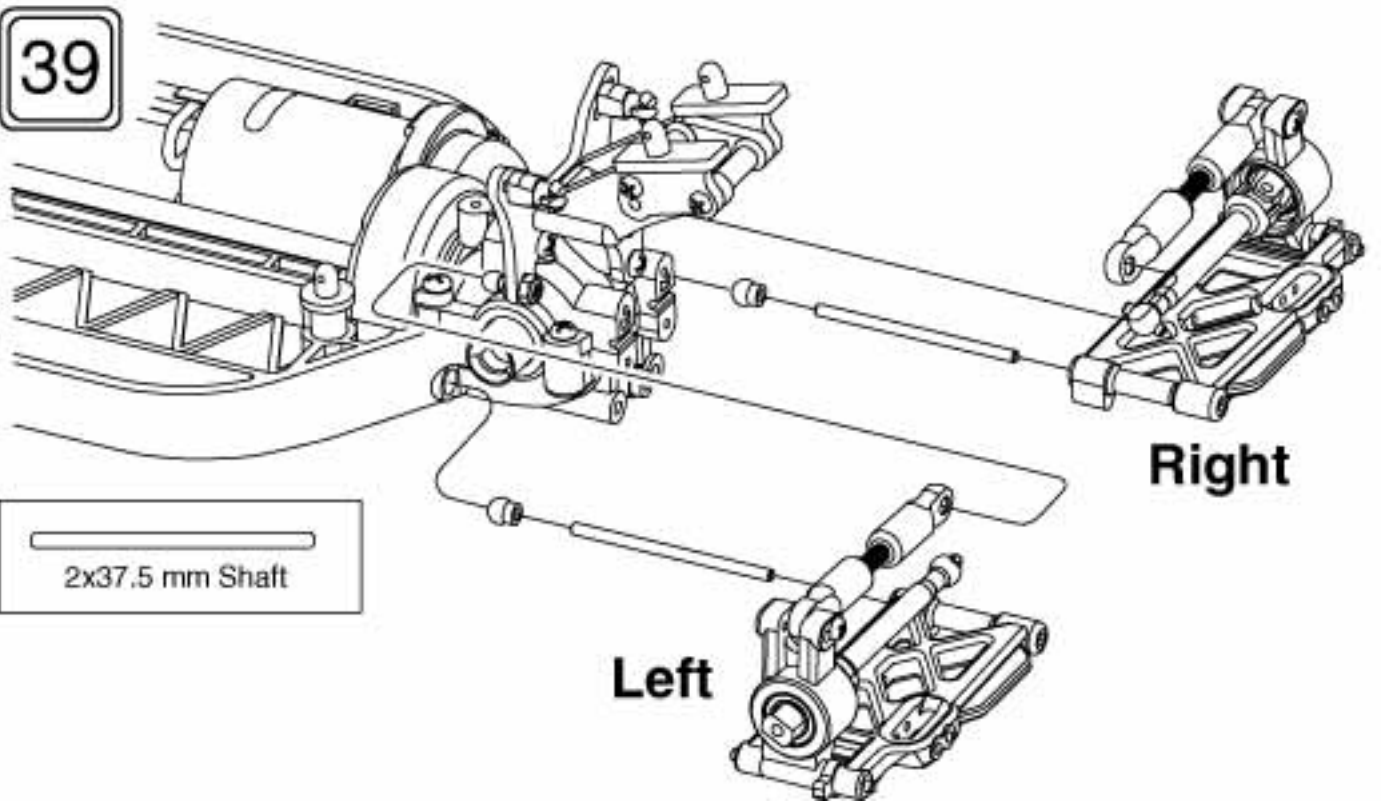

39

-  2x37.5 mm Shaft



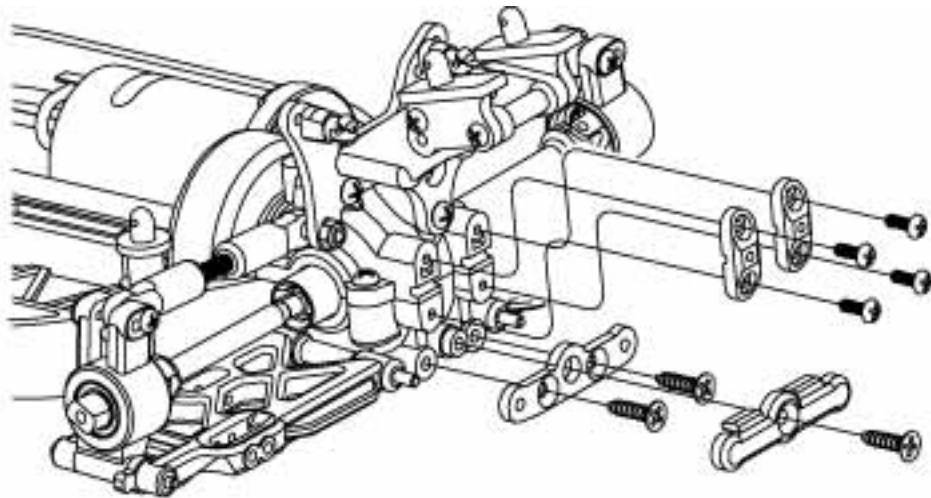

40

-  ...3  
2.6x10 mm  
S/T Screw
-  ...4  
2x6 mm  
S/T Screw



41

### Front Shocks x2

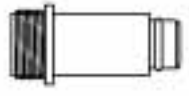

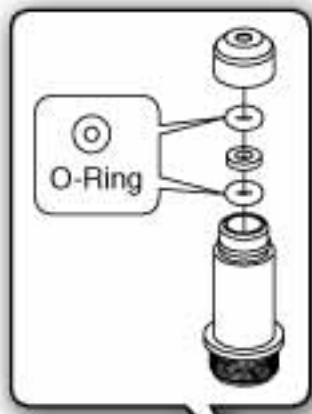

-  ...4  
O-Ring
  -  ...4  
1.5 mm E-Clip
- 
- 



Apply a small amount of oil to the shock shaft before inserting into the shock assembly. This will help prevent the shock shaft from tearing the O-rings.

42

### Rear Shocks x2

-  ...4  
O-Ring
  -  ...4  
1.5 mm E-Clip
- 
- 

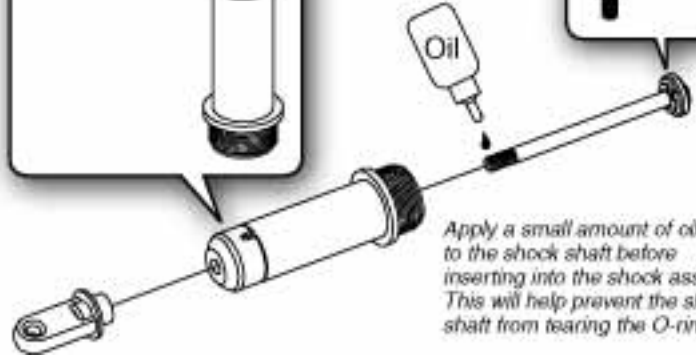
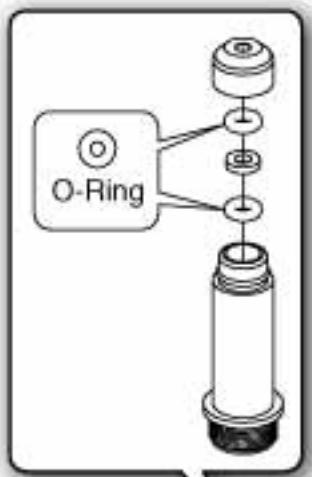

Apply a small amount of oil to the shock shaft before inserting into the shock assembly. This will help prevent the shock shaft from tearing the O-rings.

43

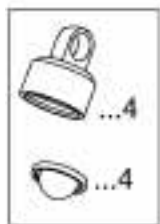

Completely fill the shock body with shock oil. Slowly work the piston up and down to remove air bubbles. Do not push the piston out of the shock oil. Slowly tighten the shock cap onto the shock body to allow the remaining air to escape.

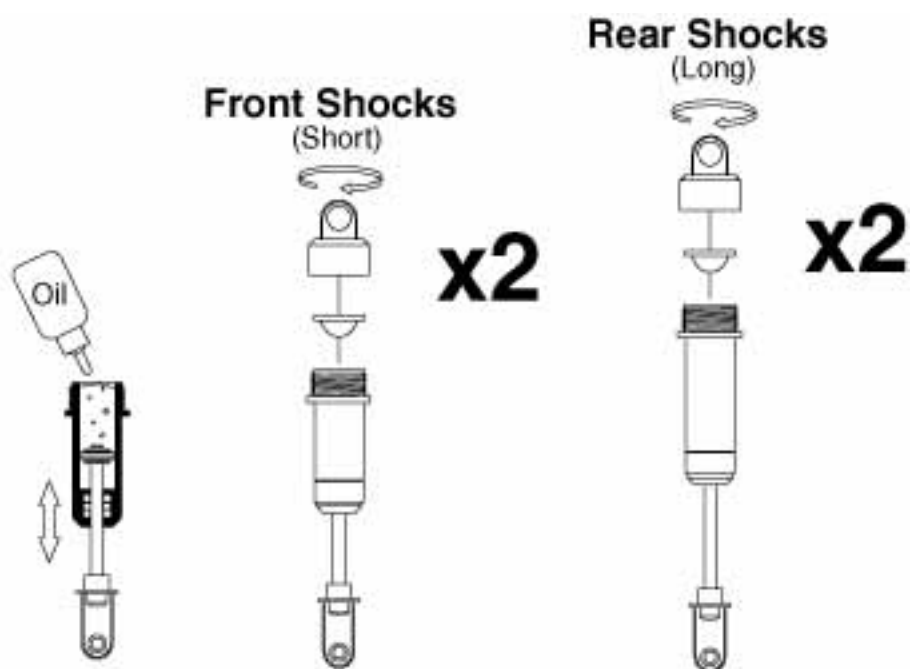

44

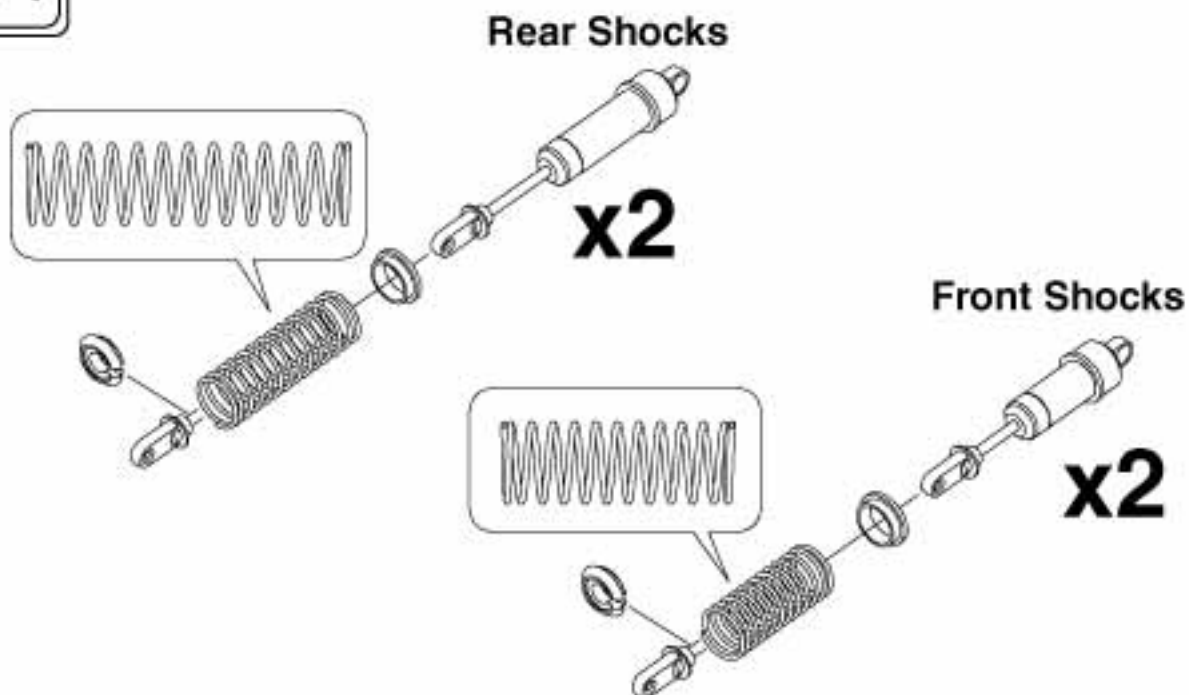

45

Rear Shocks

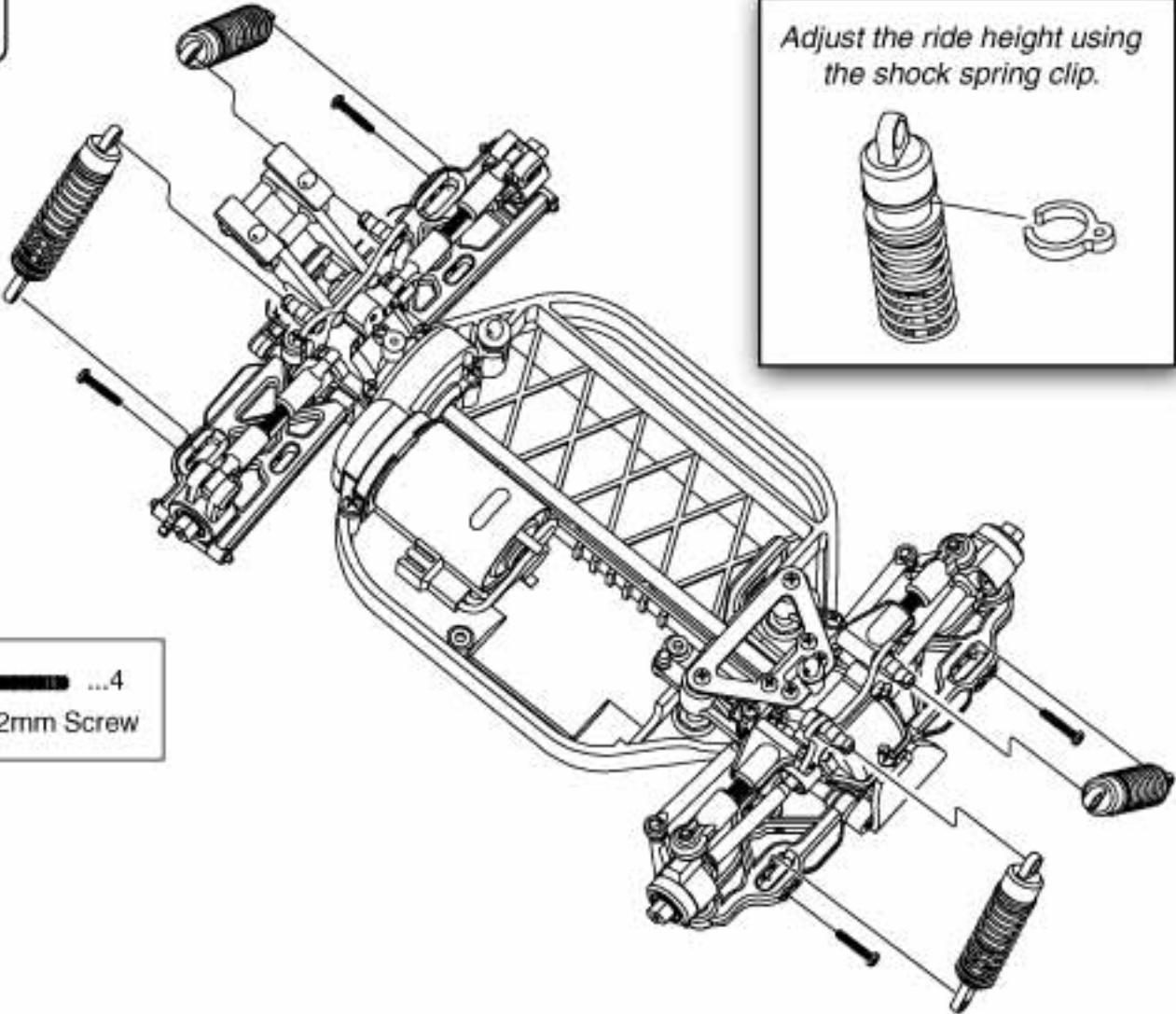

Adjust the ride height using the shock spring clip.

Front Shocks

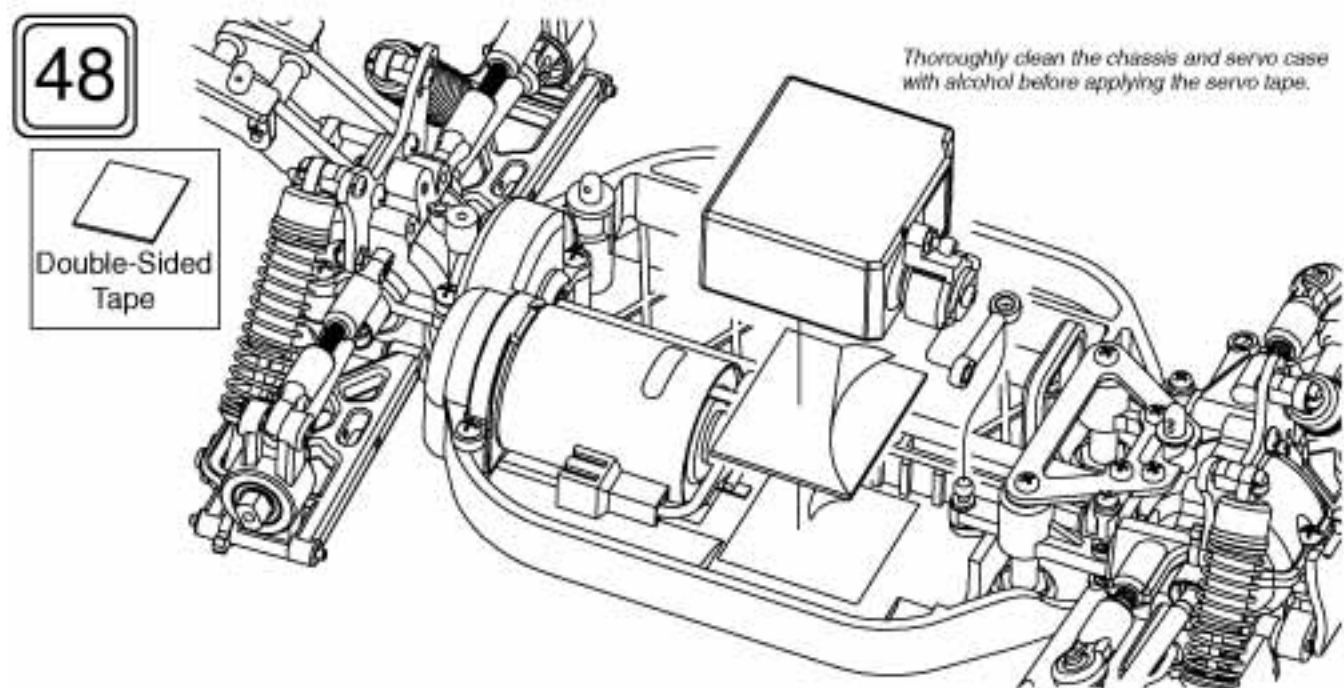
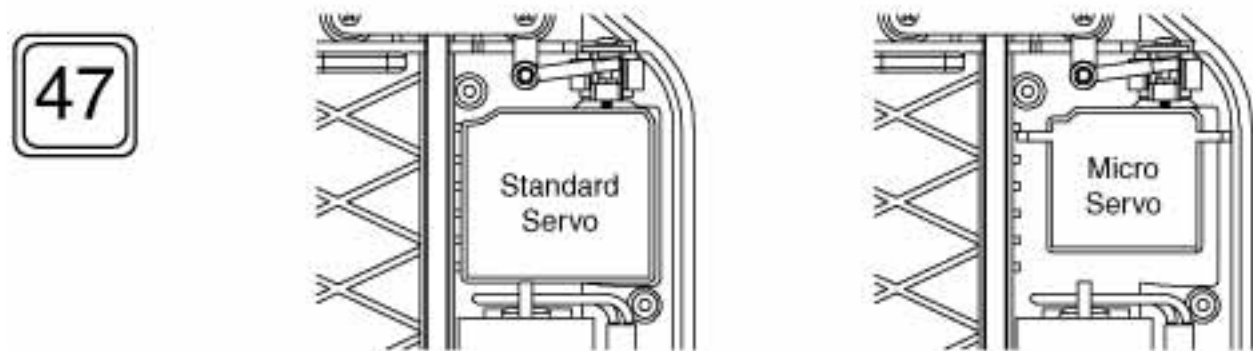
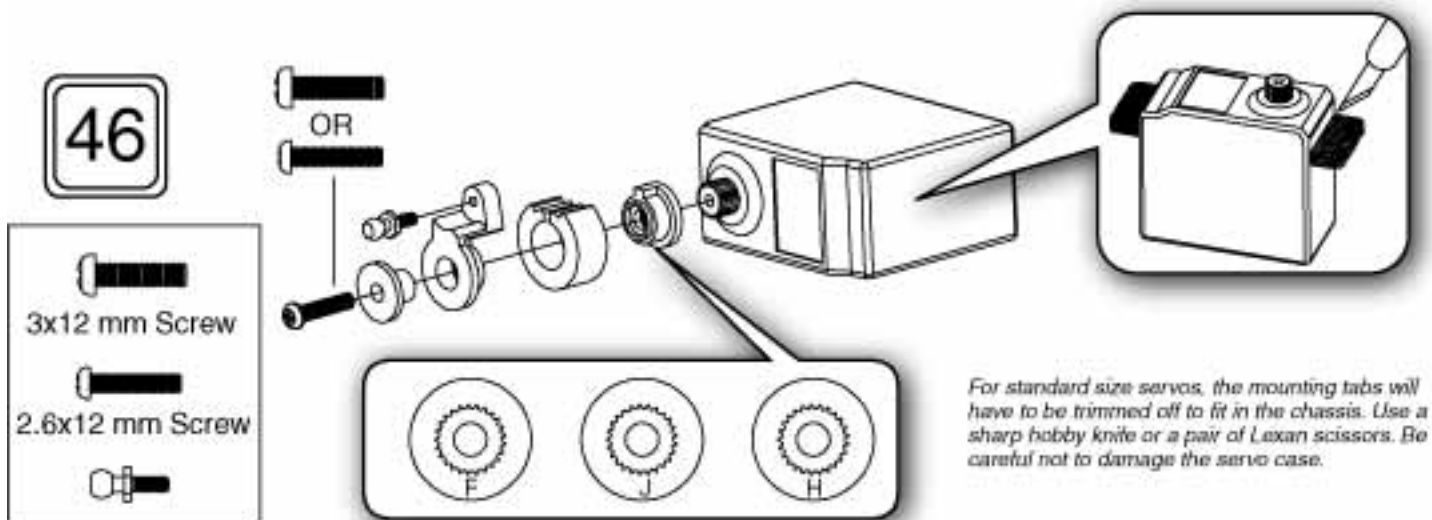





52

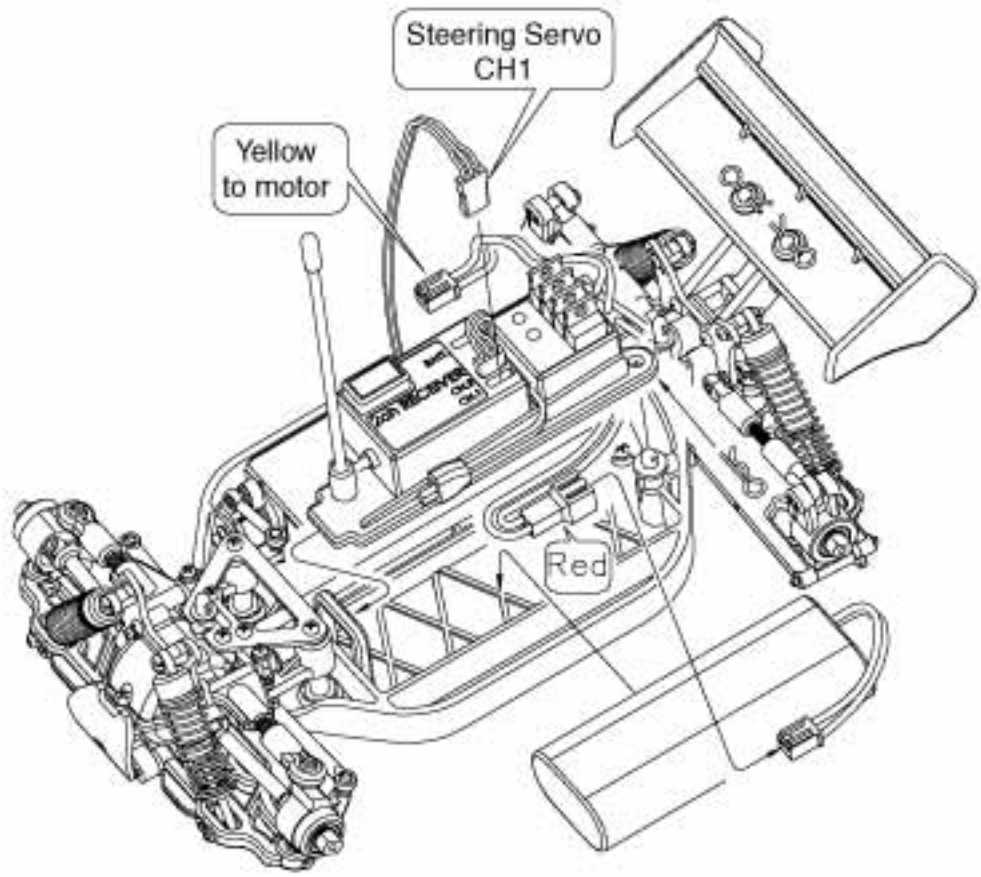

53

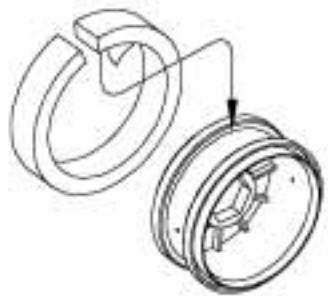

54

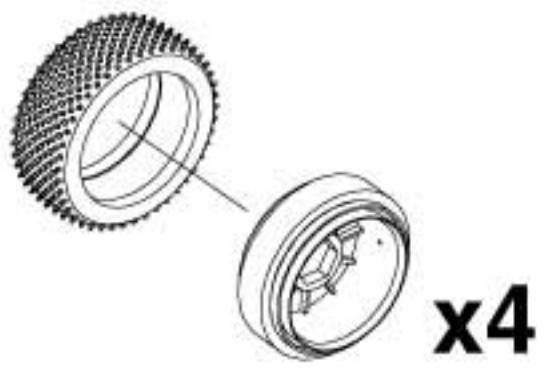

55

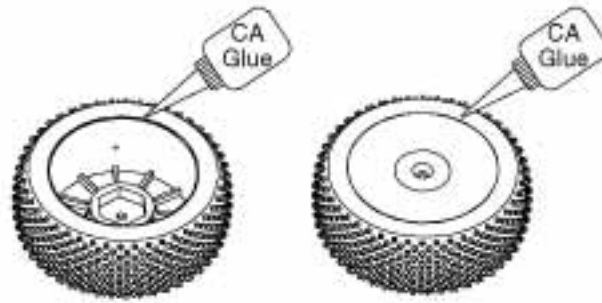

56

 ...4  
2.6x10 mm S/T Screw

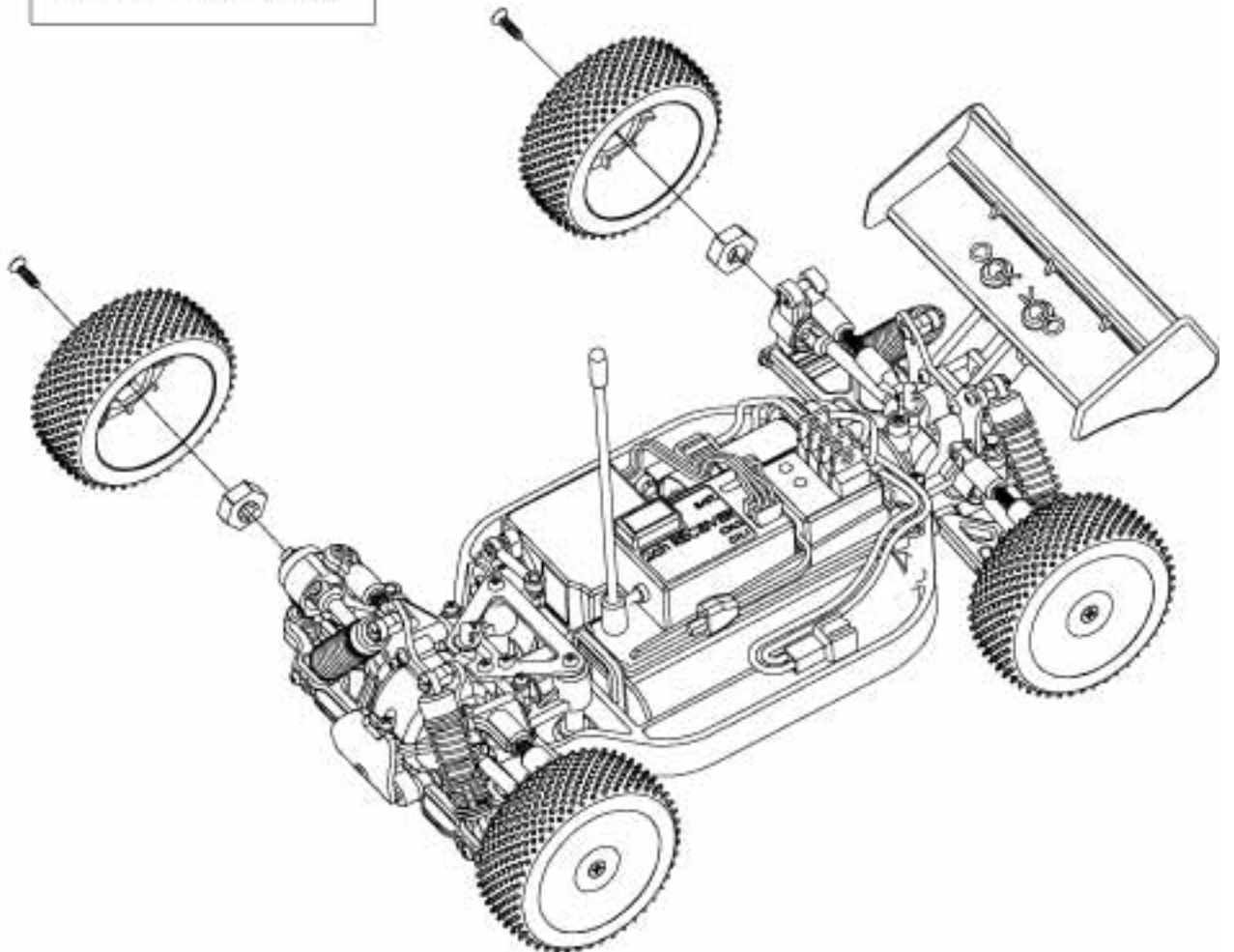

**OTHER ITEMS AVAILABLE FROM DURATRAX**



Pit Tech™ Mini Car Stand  
DTXC2361, DTXC2362  
DTXC2363, DTXC2364



AC/DC Piranha™ Digital Charger  
DTXP4005



6-cell NIMH Battery  
DTXC2195



Long Nose Pliers  
DTXR0300

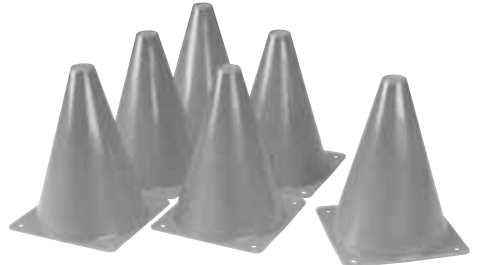

Kwik Trak 7" Racing Cone (6)  
DTXC2377

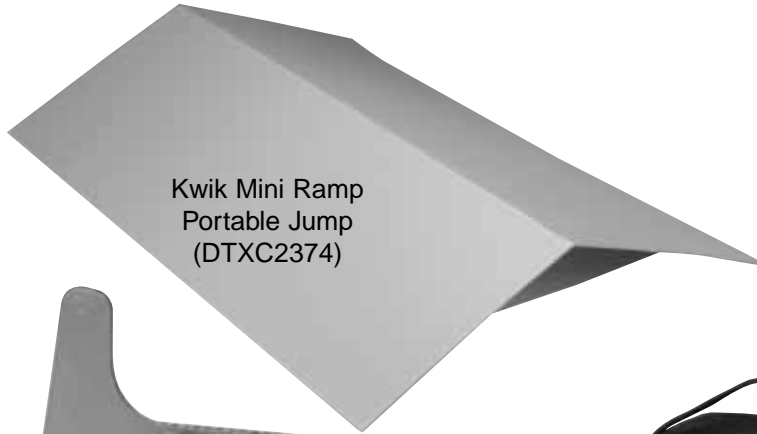

Kwik Mini Ramp  
Portable Jump  
(DTXC2374)



Ultimate Driver Set  
DTXR0183



Pit Tech™ Camber Gauge  
DTXR1145



TX NiCad Conversion Kit  
(For use with DuraTrax & Futaba Systems)  
DTXP4010



1/18th Micro Vehicle  
Carry Bag  
DTXP2028



Power Shot  
Motor Cleaner 12oz  
DTXC2459

Visit our website at [www.duratrax.com](http://www.duratrax.com) for more exciting products from DuraTrax!

# ***DURATRAX***