

DXTR 500™



DURATRAX
®

REQUIRED TOOLS



Threadlocker
DTXR0288



Needle Nose Pliers
DTXR0300



Phillips Screwdriver
DTXR0124

Flat Blade Screwdriver
DTXR0102

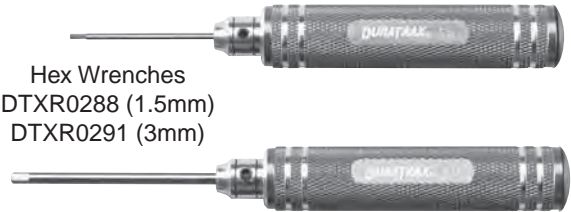

Hex Wrenches
DTXR0288 (1.5mm)
DTXR0291 (3mm)



2mm Wrench
(Included)

ITEMS REQUIRED FOR OPERATION

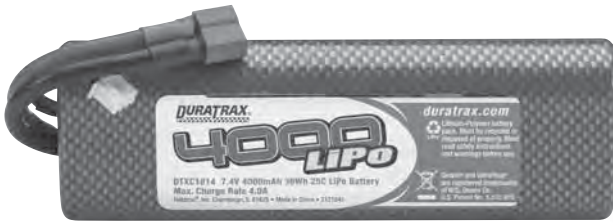

7.4V 2S LiPo Battery **DTXC1814** or
7.2V 6-Cell Battery **DTXC2054**



(4) AA Batteries



Peak Charger
 ONYX 200 AC/DC Sport (**DTXP4200**)
 ONYX 210 AC/DC with LCD (**DTXP4210**)
 ONYX 220 AC/DC Programmable with LCD (**DTXP4220**)
 ONYX 230 AC/DC Advanced with LCD (**DTXP4230**)
 ONYX 235 AC/DC Balancing (**DTXP4235**)
 ONYX 240 AC/DC Dual Peak with LCD (**DTXP4240**)

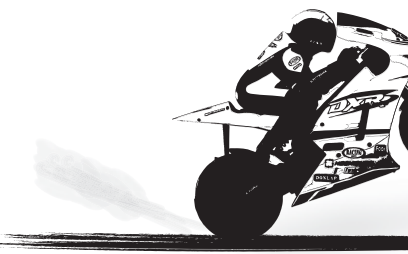

SAFETY PRECAUTIONS

When these safety precautions are followed, the DXR500 will provide years of enjoyment. Use care and good sense at all times when operating this radio controlled motorcycle. Failure to use this vehicle in a safe, sensible manner can result in injury or damage to property. You and you alone must ensure that the instructions are carefully followed and all safety precautions are obeyed.

- Do not operate the DXR500 near people. Spectators should be behind the driver or at a safe distance away from the bike.
- Make sure to read the instructions included with the battery and charger before charging the battery.
- Do not leave any charger unattended during charging. If the battery or charger become hot at any time, disconnect the battery from the charger immediately! Failure to do so may cause permanent damage to the charger and battery and may cause bodily harm or property damage.
- Do not cover the air intake holes on the charger during charging. This may cause the charger to overheat.
- Do not allow the electronic speed control (ESC) or other radio equipment to come into contact with moisture. Water can cause electronics to short out and can cause permanent damage.
- Always turn on the transmitter before turning on the ESC.
- Always turn off the ESC *before* turning off the transmitter.
- Allow the motor and ESC to cool before each run.

SPECIFICATION AND DESCRIPTION CHANGES

All pictures, descriptions and specifications found in this instruction manual are subject to change without notice. DuraTrax maintains no responsibility for inadvertent errors in this manual. Visit duratrax.com for the latest updates and information for your model.

HELPFUL HINTS

- Avoid working over a deep pile carpet. If you drop a small part or screw, it may be difficult to find.
- Place a mat or towel over your work area. This will prevent parts from rolling off and protect the work surface.
- Avoid running the motorcycle in cold weather. The plastic and metal parts can become brittle at low temperatures. In addition, grease and oil become thick, causing premature wear and poor performance.
- Test fit all parts before attaching them permanently.

STRESS-TECH™ PARTS GUARANTEE

We have engineered the DXR500 to take the rough and tumble abuse that makes R/C fun. We are so confident of the quality and durability of the Stress-Tech plastic parts that we will replace any Stress-Tech plastic part you break during the first 12 months you own the motorcycle. Just send in the part to us and we will send you a FREE replacement. Please see the parts list for the items covered under the Stress-Tech guarantee.

To receive your free replacement part please send the following to the Hobby Services address listed under the warranty.

- 1. The broken part must be included.
- 2. The part number and description of the broken part.
- 3. Copy of the dated invoice or purchase receipt.
- 4. Your name, phone number and shipping address.

WARRANTY

- DuraTrax® guarantees this kit to be free from defects in both material and workmanship at the date of purchase. DuraTrax will warranty this kit for 90 days after the purchase date. DuraTrax will repair or replace, at no charge, the incorrectly made part.
- Make sure you save the receipt or invoice you were given when you bought your model! It is your proof of purchase and we must see it before we can honor the warranty. Further, DuraTrax reserves the right to change or modify this warranty without notice.
- In that DuraTrax has no control over the final user assembly or material used for final user assembly, no liability shall be assumed nor accepted for any damage resulting from the use by the user of the final user-assembled product. By the act of using the user-assembled product, the user accepts all resulting liability.

To return your DXR500 for repairs covered under warranty, you should send your motorcycle to:

Hobby Services
3002 N. Apollo Drive Suite 1
Champaign, Illinois 61822
Attn: Service Department
Phone: (217) 398-0007
9:00 am–5:00 pm Central Time M-F
E-mail: hobbyservices@hobbico.com
hobbyservices.com

If you are not prepared to accept the liability associated with the use of this product, you are advised to return this kit immediately in new and unused condition to the place of purchase.

REPAIR SERVICE

Repair service is available anytime.

- After the 90 day warranty, you can still have your DXR500 repaired for a small charge by the experts at DuraTrax's authorized repair facility, Hobby Services.
 - To speed up the repair process, please follow the instructions listed below.
1. Under most circumstances return the ENTIRE vehicle. The exception would be sending in a Stress-Tech part. See the instruction under the Stress-Tech Guarantee.
 2. Make sure the transmitter is turned off, and all of the batteries are removed.
 3. Send written instructions which include: a list of all items returned, a **THOROUGH** explanation of the problem, the service needed and your phone number during the day. If you expect the repair to be covered under warranty, be sure to include a proof of date of purchase (your store receipt or purchase invoice).

TRANSMITTER PREPARATION

- Slide off the battery tray door and install four “AA” batteries. Make sure the polarity is correct.



- Raise the antenna at the top of the transmitter.

- Turn on the transmitter and check the battery light. If the red light glows steadily, the batteries have enough voltage. If the red light blinks, the batteries are low and should be replaced.

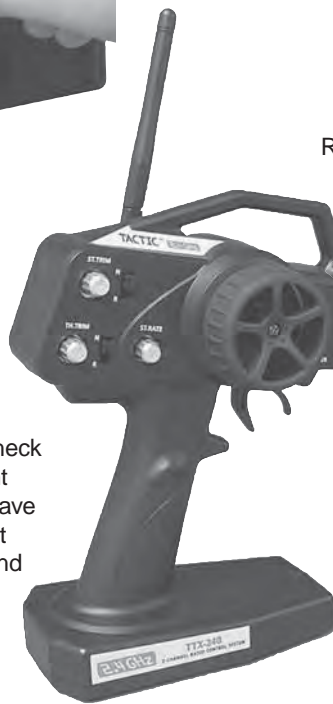

RED BATTERY LIGHT

- The receiver should be factory bound to the transmitter. However, if you ever need to bind, follow these steps:

1. Turn on the transmitter.
2. Turn on the receiver via the switch on the ESC. If the receiver is not bound, the LED light will not be on.
3. Push and hold the bind button on the receiver until the light glows red.
4. Release the bind button.
5. If the binding is successful, the LED will flash once and then remain ON.

STABILIZER BAR INSTALLATION



ASSEMBLE THE BIKE STAND

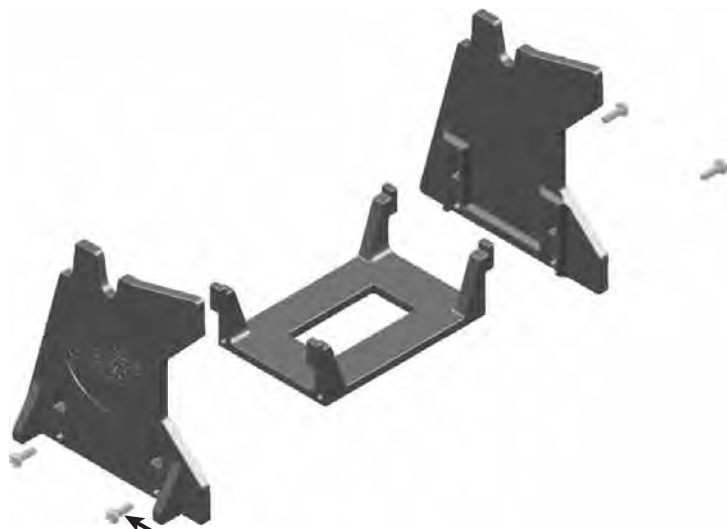

3x8mm BH Screws

4x8mm Bushings

3mm Nylon Nut

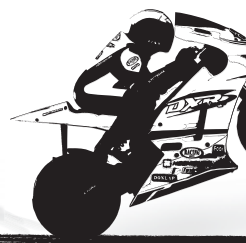

BATTERY INSTALLATION



- Remove the body clip from the battery door post.



- Slide the battery door off.

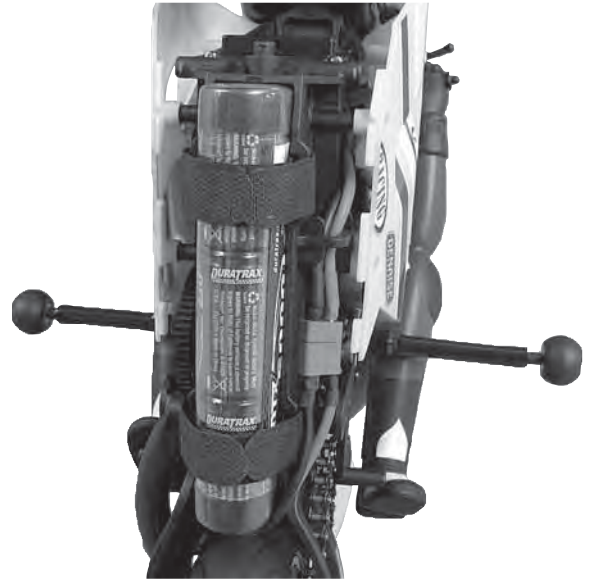

- Install the battery into the battery holder and secure in place with the hook and loop straps. With the ESC "OFF", plug the battery into the ESC lead.
- Re-install the battery door and secure in place with the body clip.

STEERING SETUP

The DXR500 comes with a CS Steering System (counter-steering) where the direction of the transmitter steering wheel and the DXR500's front wheel are opposite.

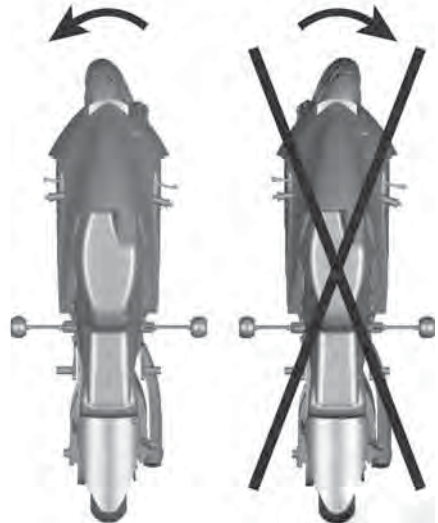
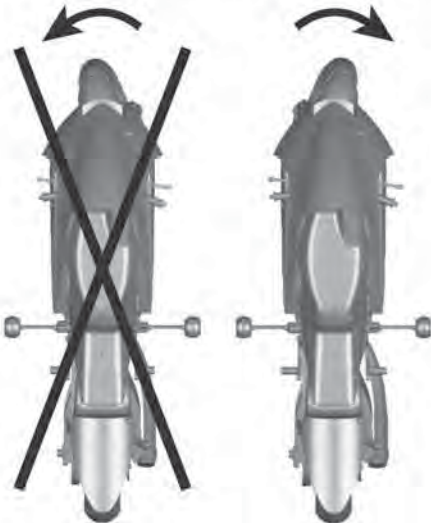

IMPORTANT OPERATION NOTES

The best place to operate your DXR500 is on a large, open parking lot, clear of any traffic. For better stability, be sure to get the gyro spinning before launching the DXR500.

- Always turn the transmitter on **BEFORE** the cycle. Always turn the cycle off before the transmitter.
- Hold the cycle in the air and hold the transmitter at full throttle for 3 seconds. This spools up the gyro, making the cycle more stable at low speeds.
- Place the cycle into the stand or gently roll the bike forward and drive.
- Start off driving in large, figure-8 patterns to learn how to steer the cycle. Go slow in the turns until you get used to the way the cycle handles.
- Use smooth throttle input while learning to drive. This will make the cycle more controllable.



Display

For easier starts, use the bike stand as shown.



To Start

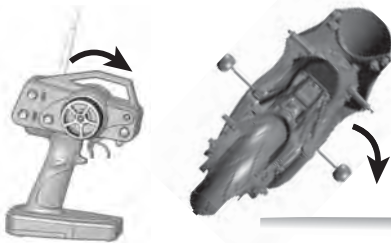

To start a right turn, gently turn the transmitter to the right. The bike will lean to the right.

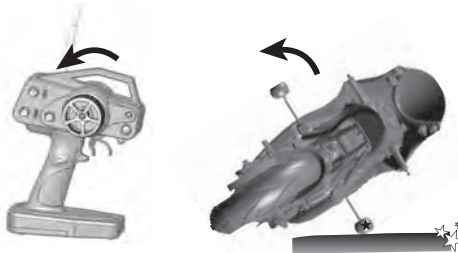

If the stabilizer bar touches the ground, the bike will not turn well. Return the transmitter wheel to neutral to lift the bike and improve turning.

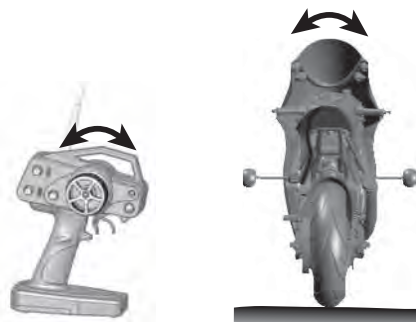

When you want to go straight again, turn the transmitter wheel in the opposite direction of the turn.

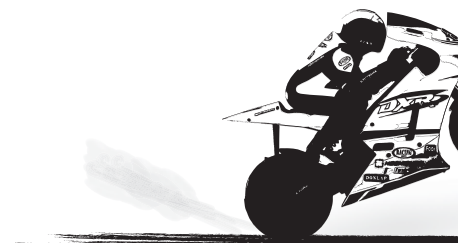

ADJUSTABLE GYRO



The weight can be adjusted by adding or removing weights in the flywheel:

- More weight gives more stability.
- Less weight gives more response and more power.

IMPORTANT! The weights must be evenly distributed to keep the gyro balanced.

SHOCK OIL

- You can adjust the dampening of the DXR500 by using different weight shock oil in the rear shock.

Thinner oil ➔ Softer Dampening

Thicker oil ➔ Stiffer Dampening



DXR500 MAINTENANCE

- Check all of the screws to make sure they are all properly tightened. Replace any screws that have fallen out during running.
- Check for any broken or missing parts so they can be replaced before the next use.
- Check for damage or wear on the gears.
- Periodically check that the rear oil shock is full of oil.

MAINTENANCE GUIDE

The following section is provided to help you with maintenance and repairs to your DXR500. Pay extra attention to the notes and tips for proper assembly.

DURATRAX
1



DURATRAX
2



DURATRAX
3

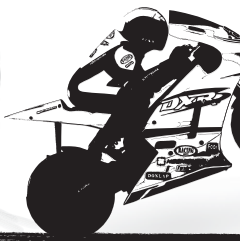
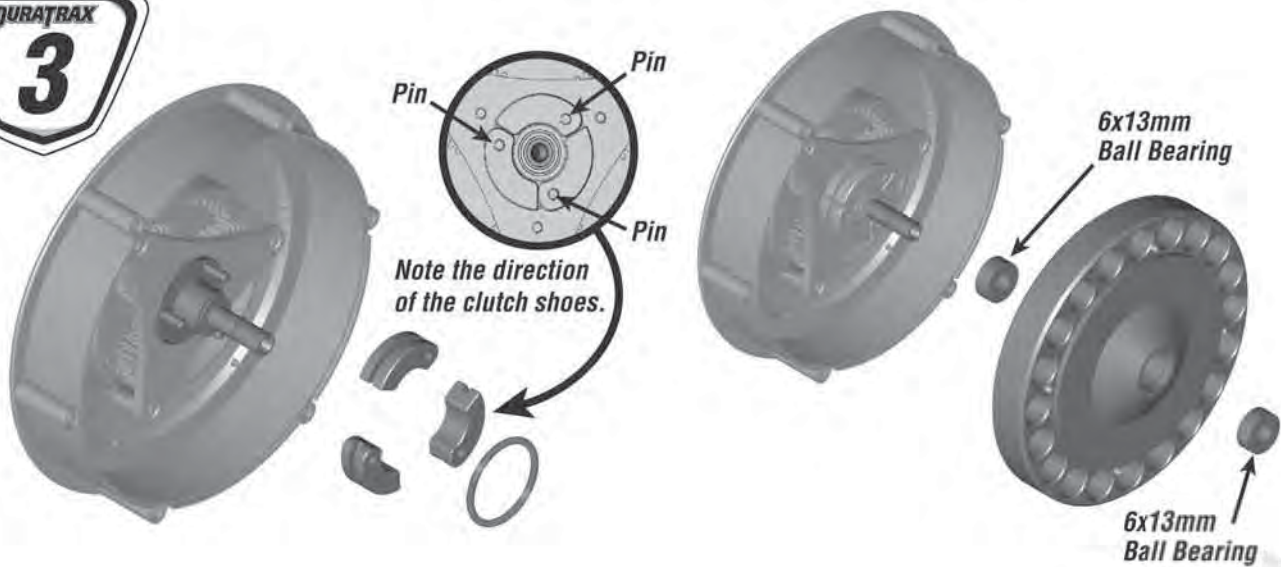

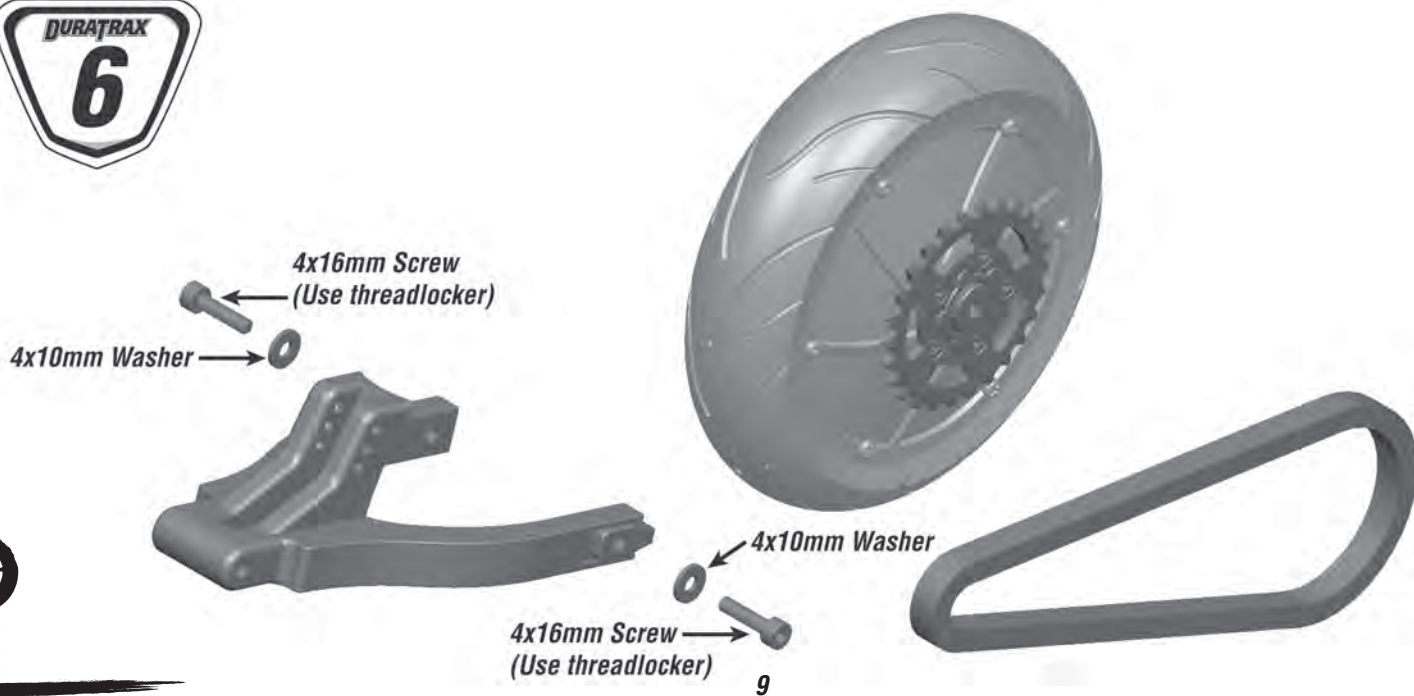
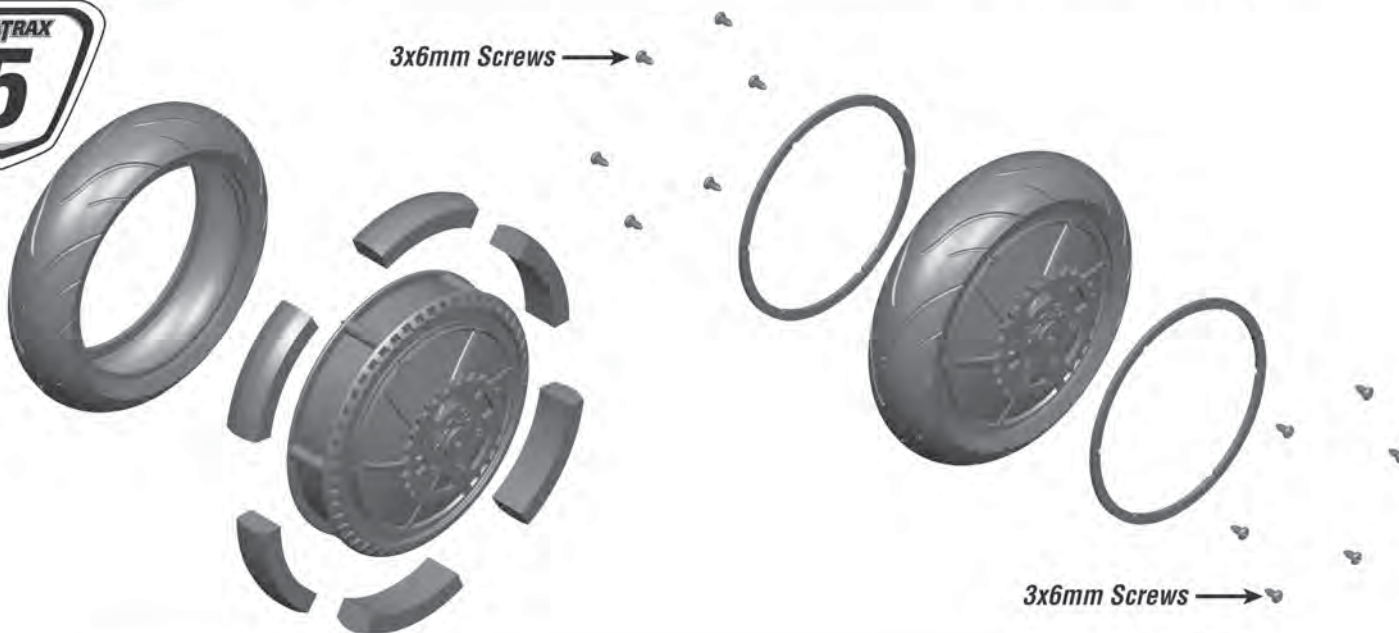
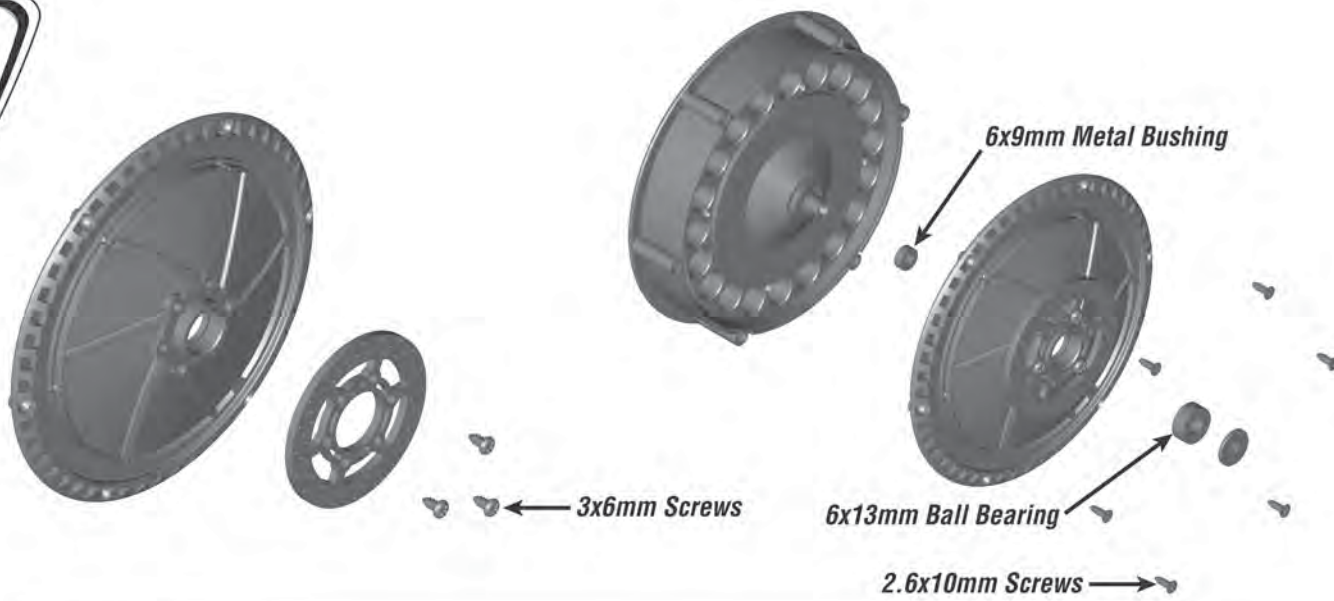

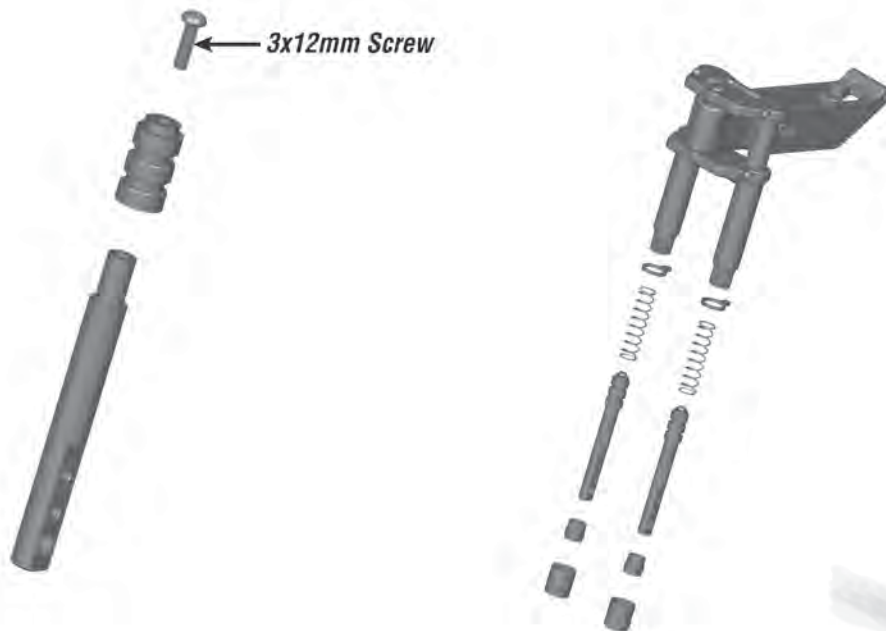
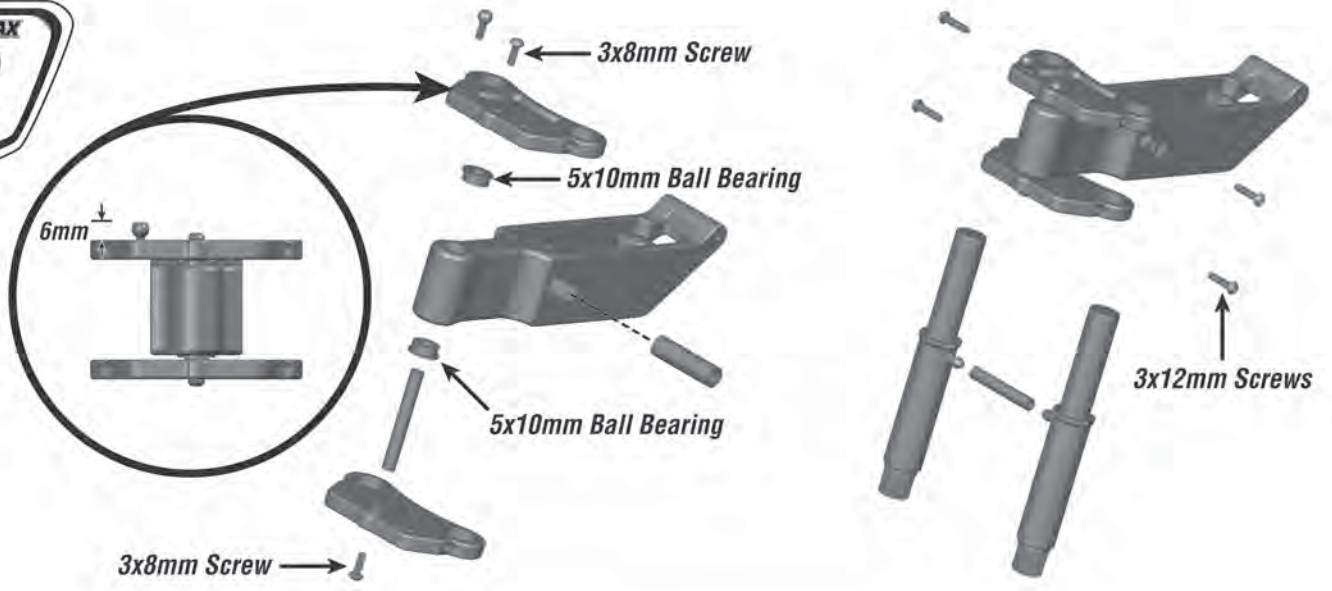
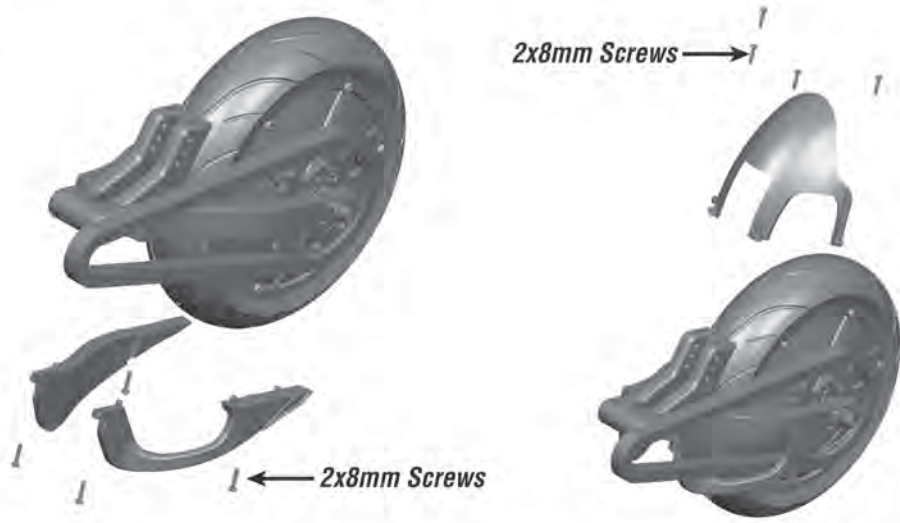



5x10mm Ball Bearing



5x10mm Ball Bearing



3x6mm Screws

3x8mm Screws

4x4mm Set Screws



3x6mm Screws



3x10mm Screws

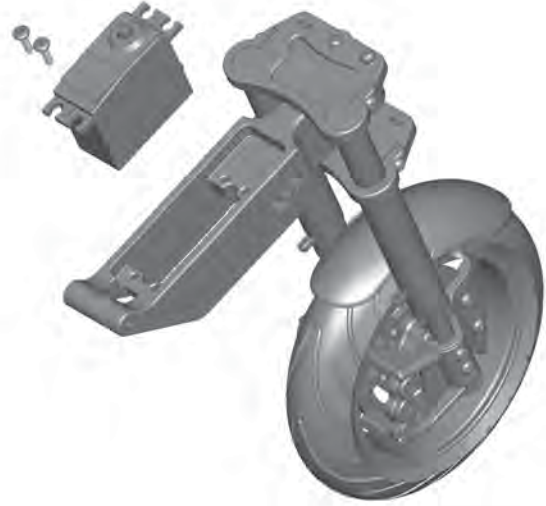

2mm E-Clip

2mm E-Clip



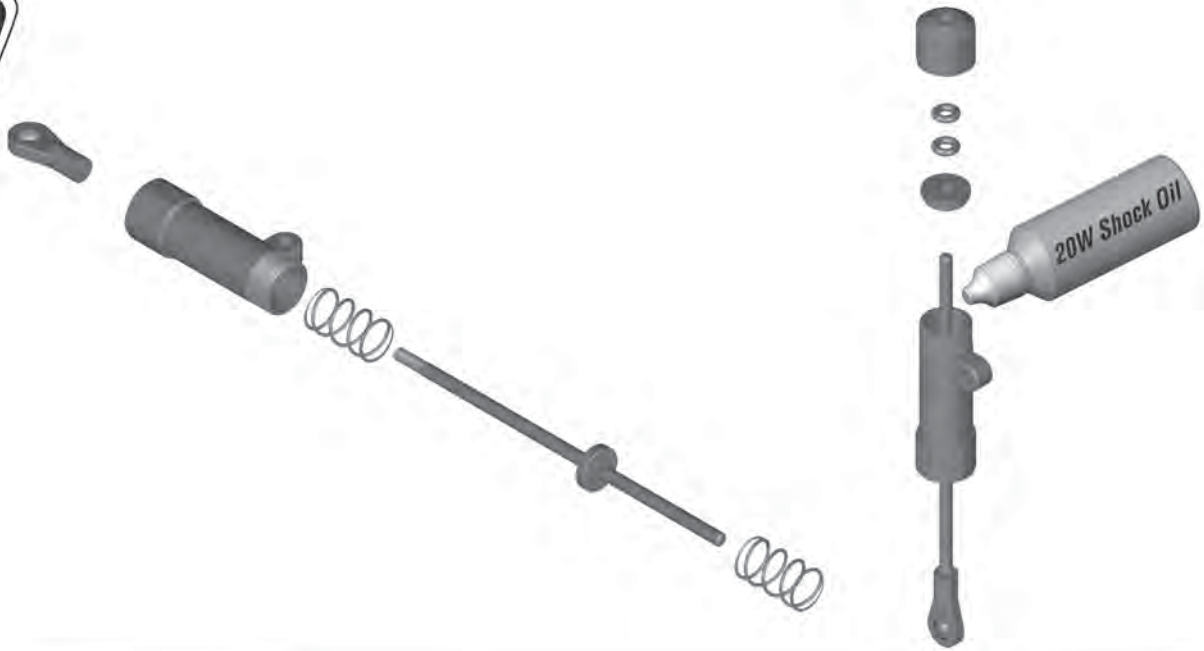

3x10mm Screw →

Screw included with servo. →

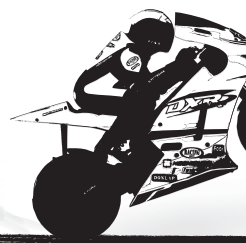
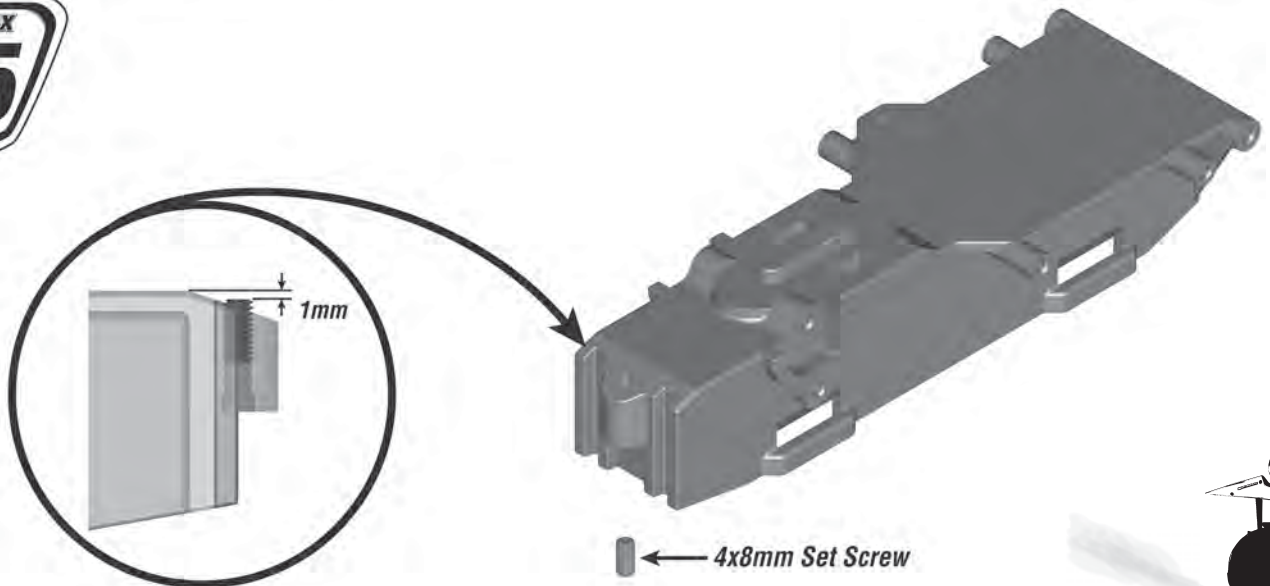
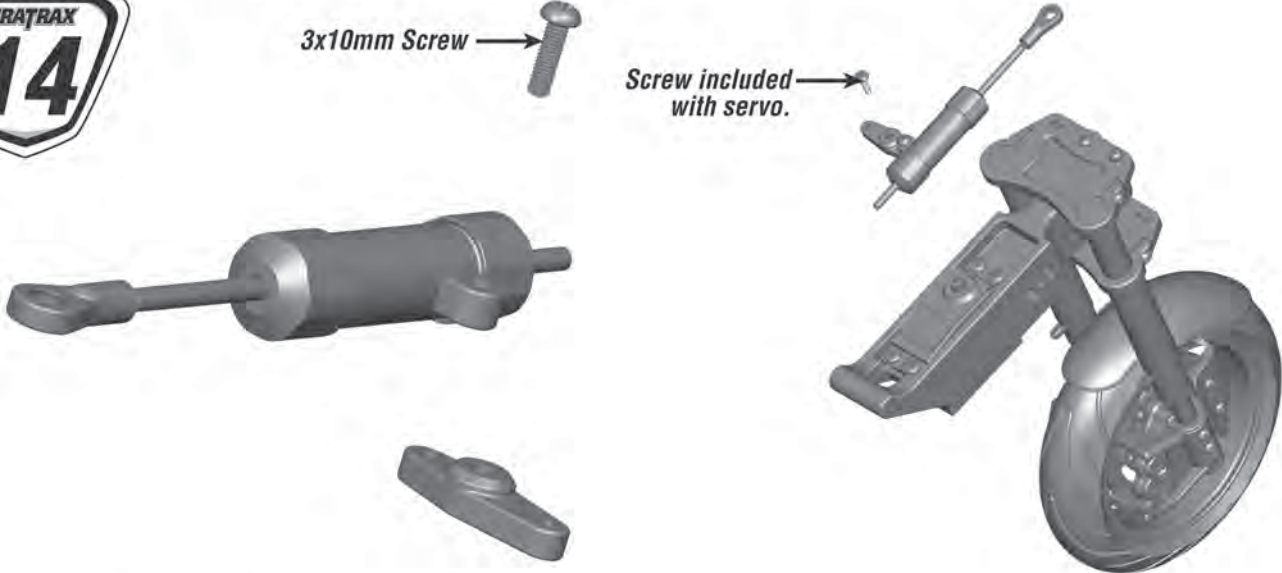

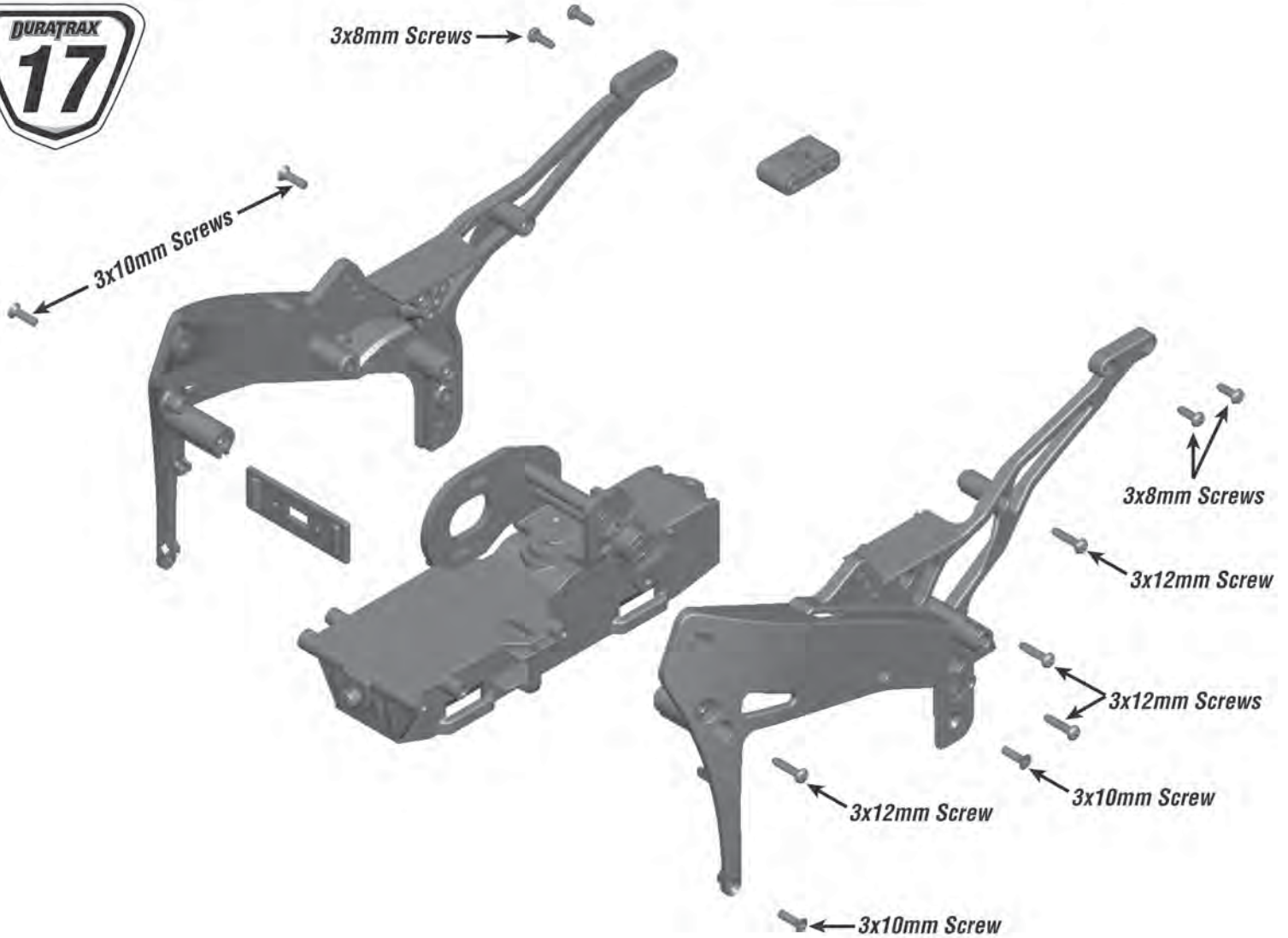
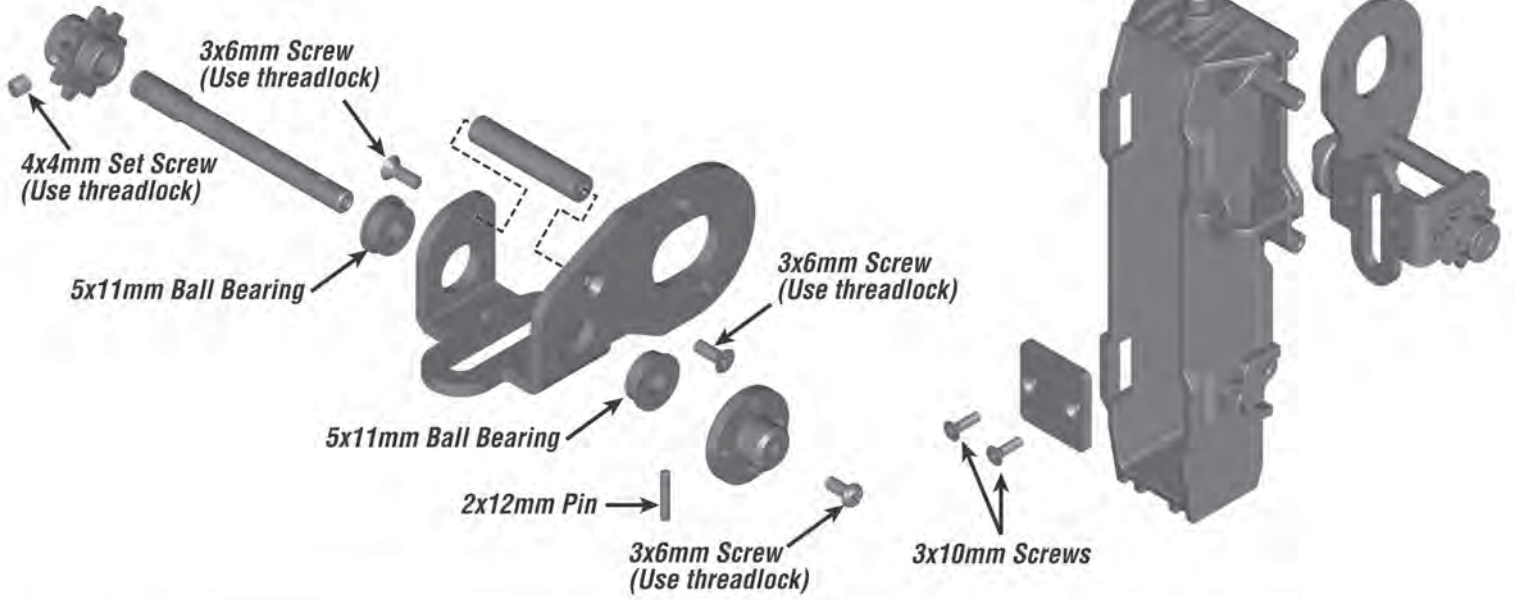



Apply a small amount of shock oil to the O-rings during assembly.



2x5mm Screw (Use threadlock)

2.5x6mm Washer



The rear shock dampening can be adjusted by using different weight shock oil.
Thinner oil → Softer dampening
Thicker oil → Stiffer dampening

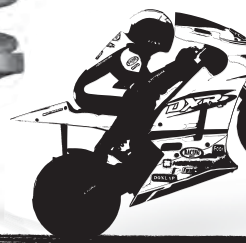
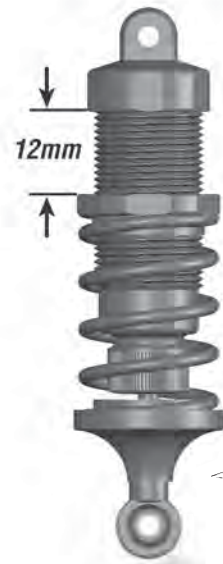

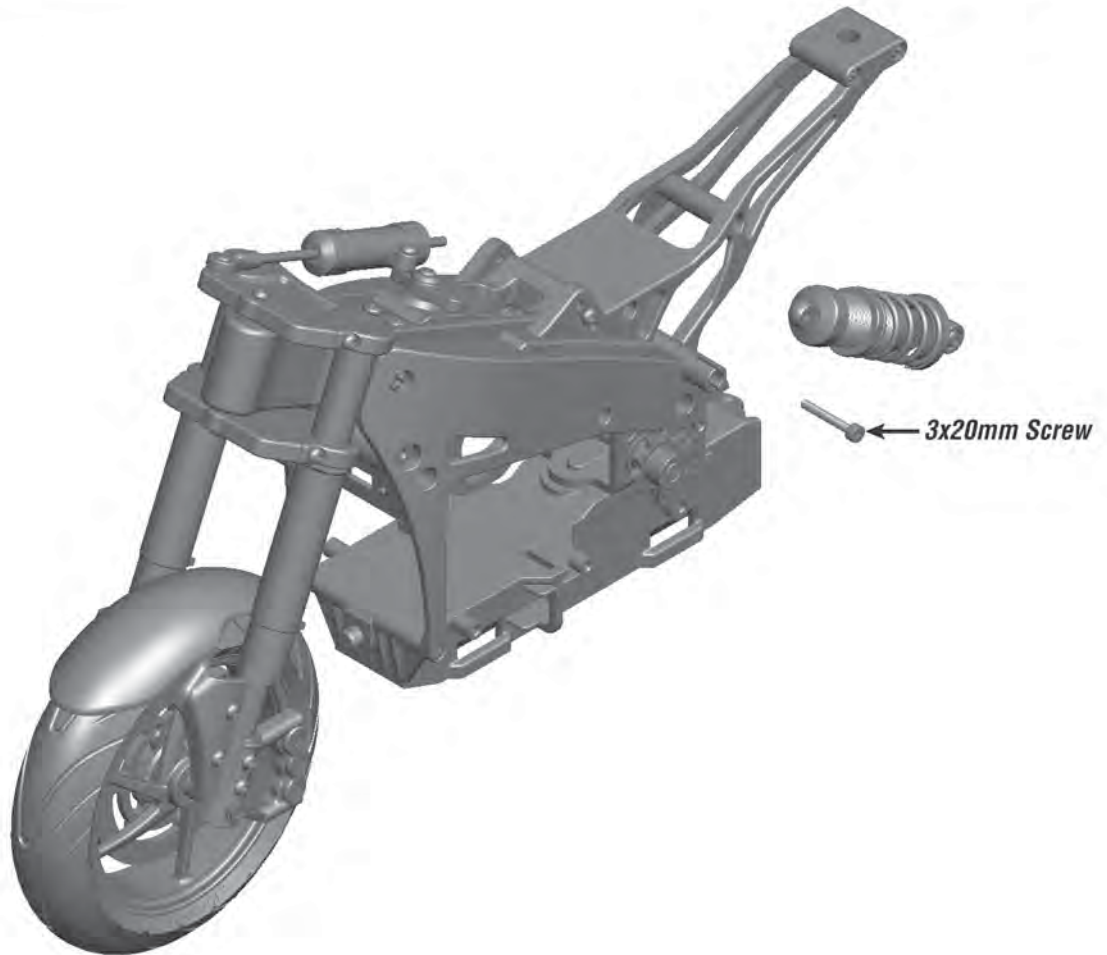
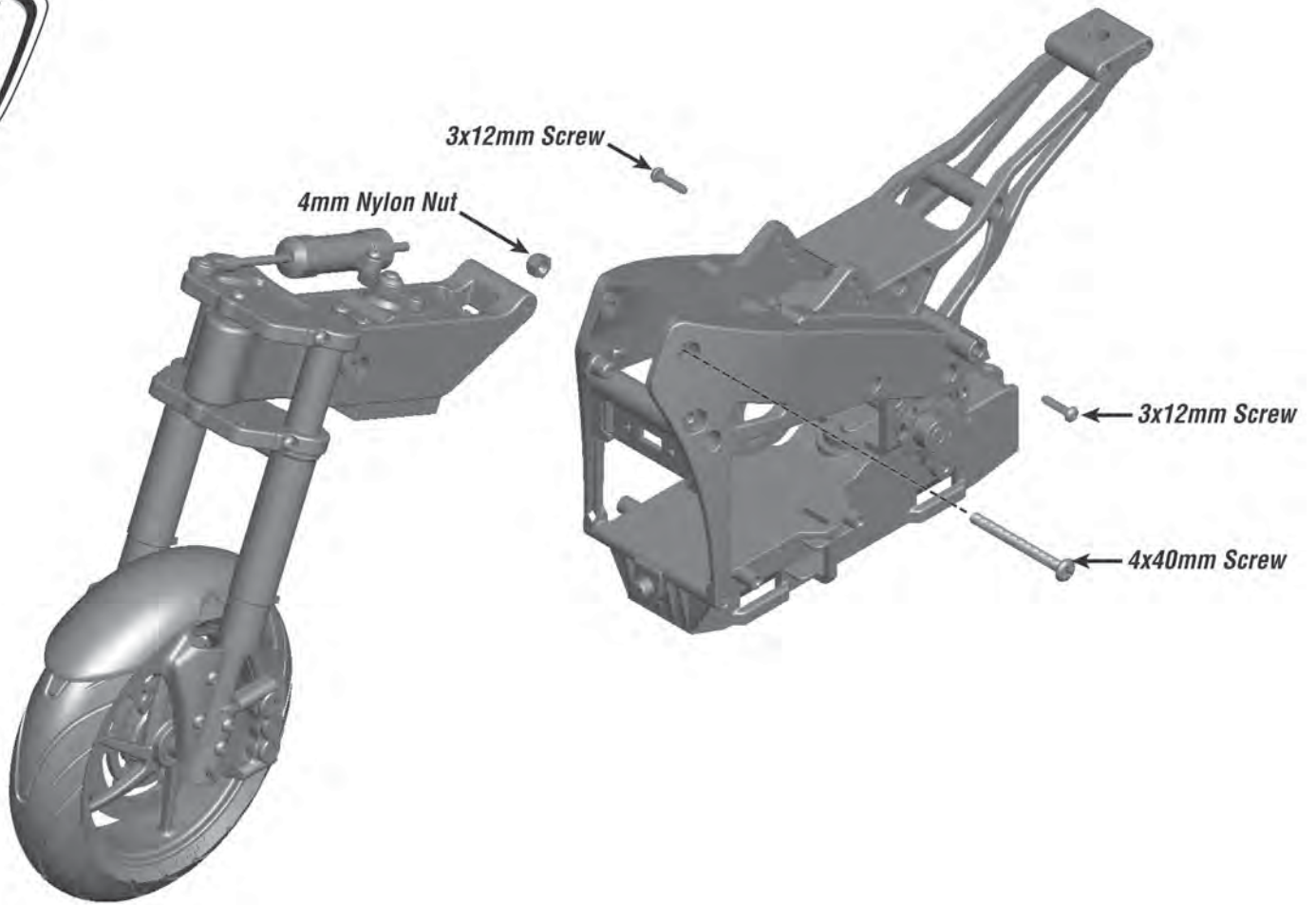

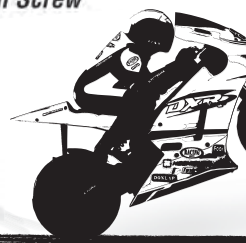
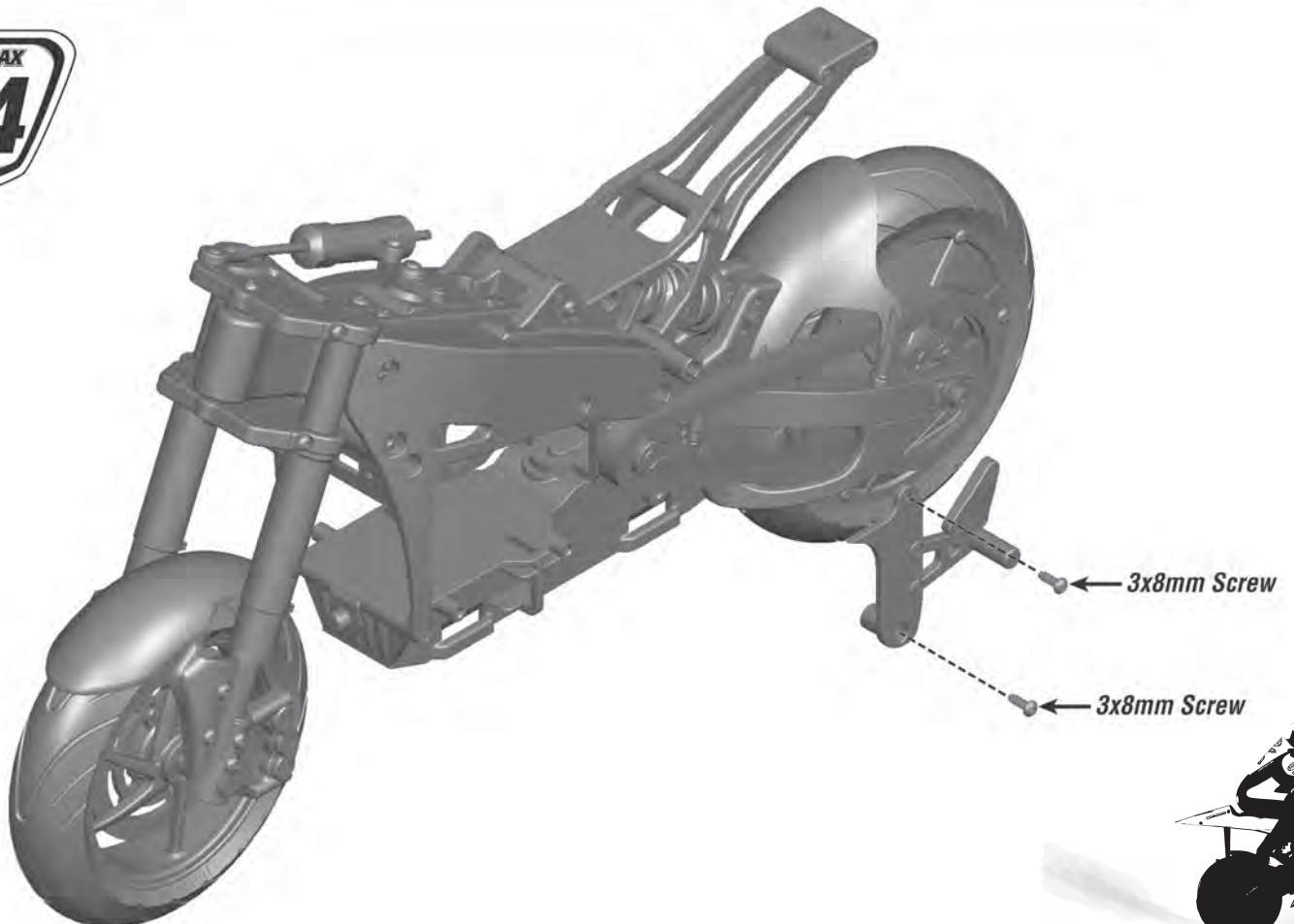
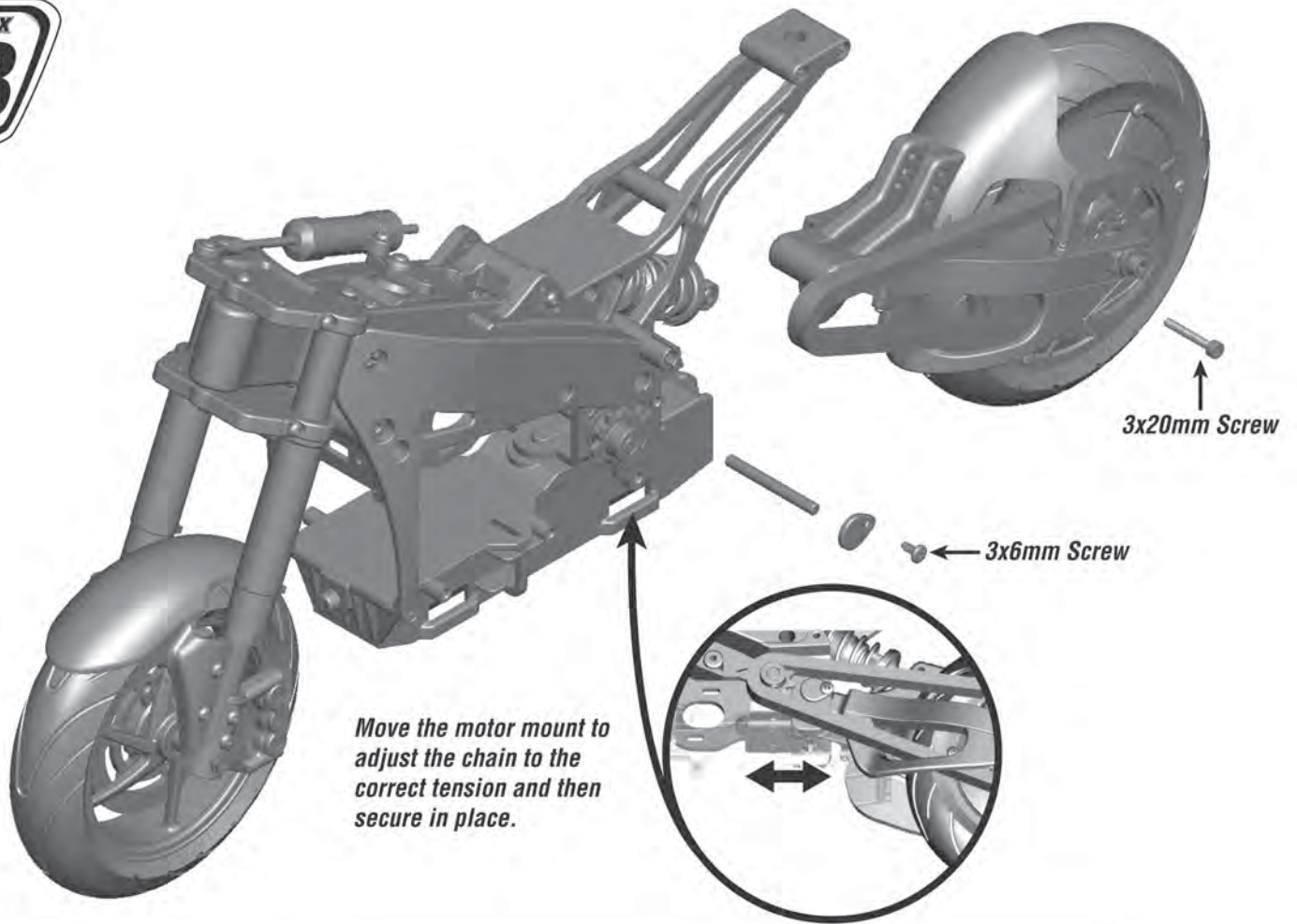

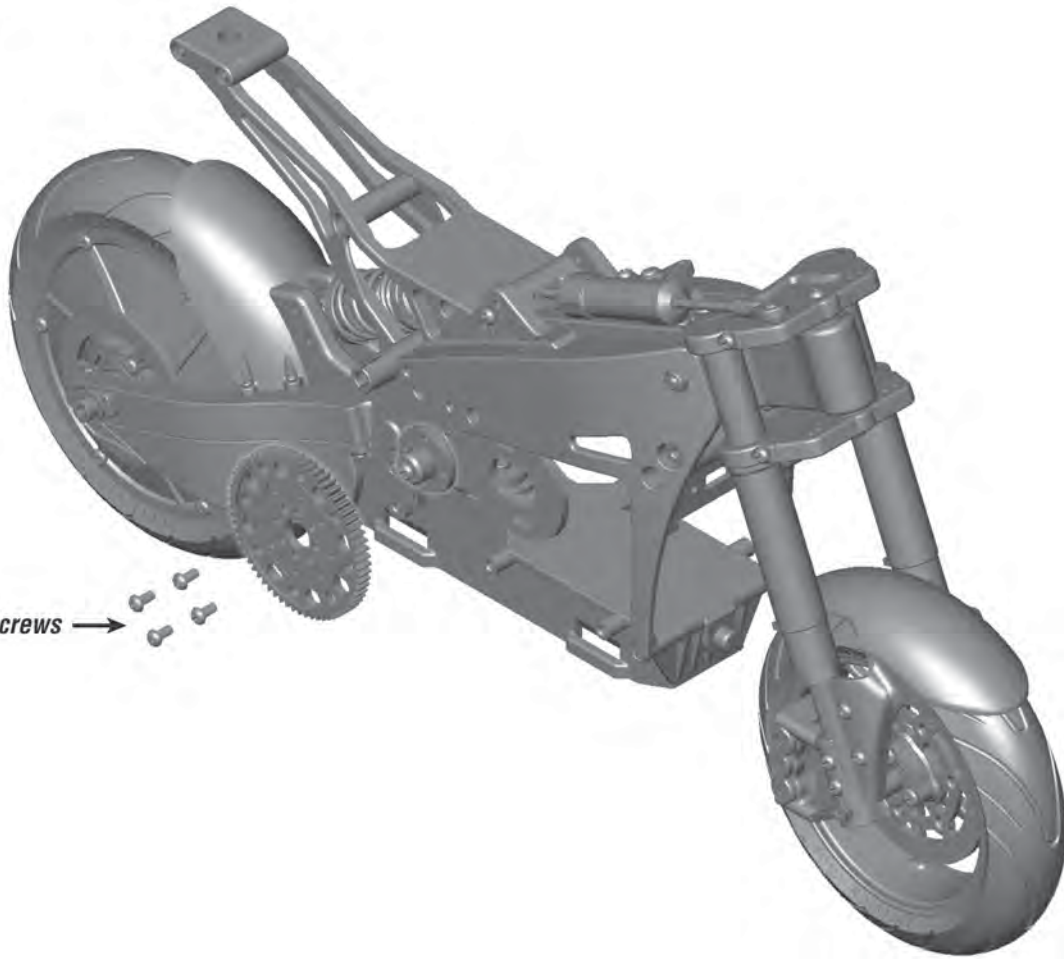

3x6mm Screws →

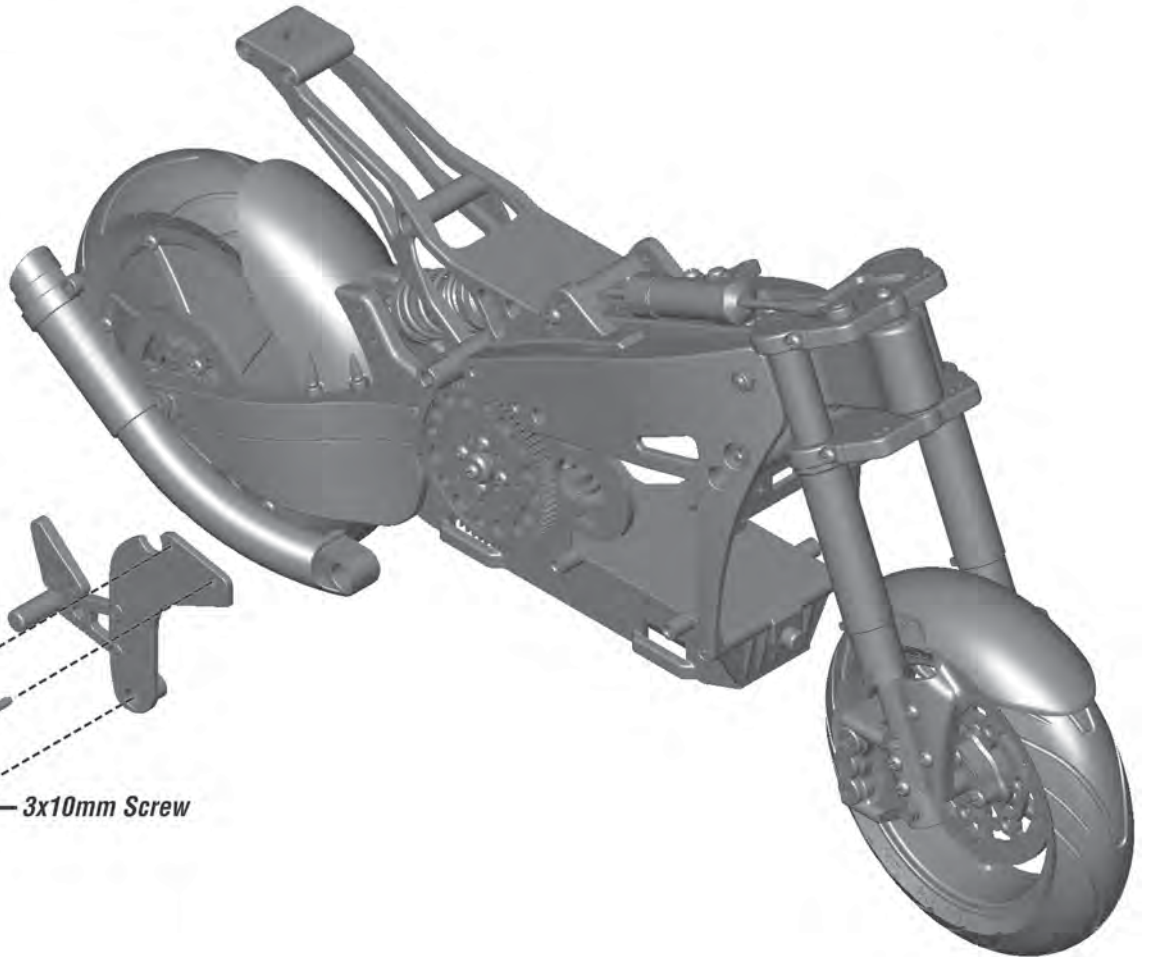

3x8mm Screws →



← 3x10mm Screw



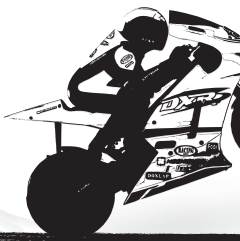
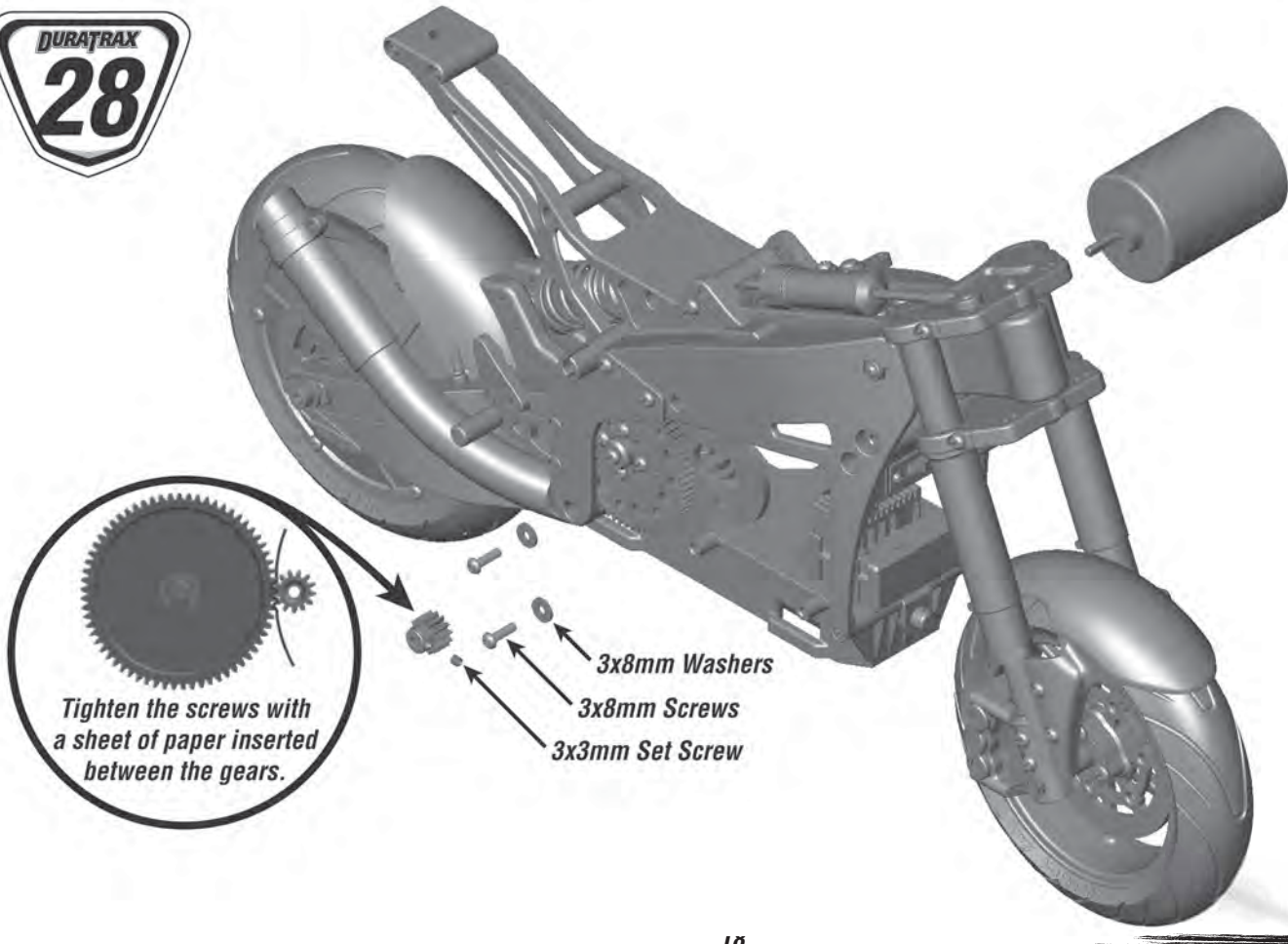
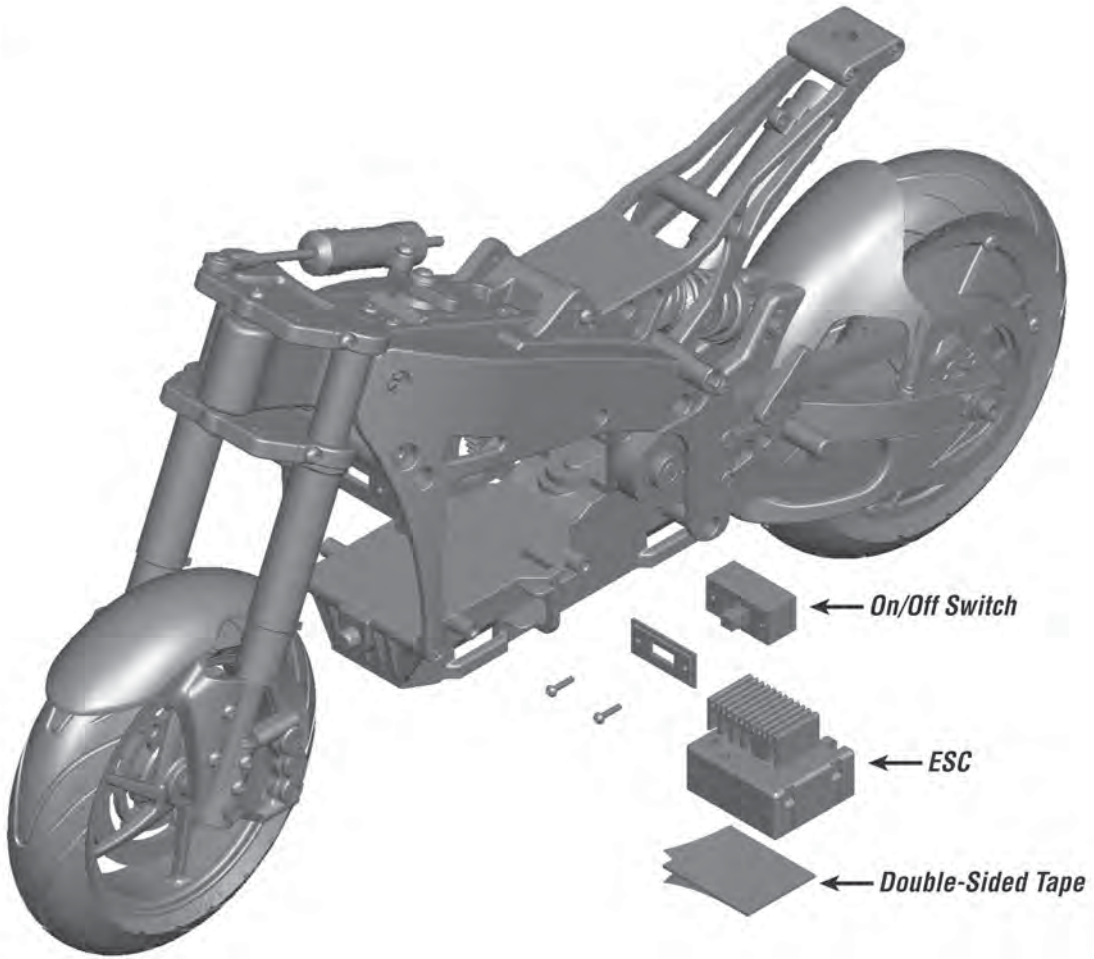



Receiver →



Double-Sided Tape →

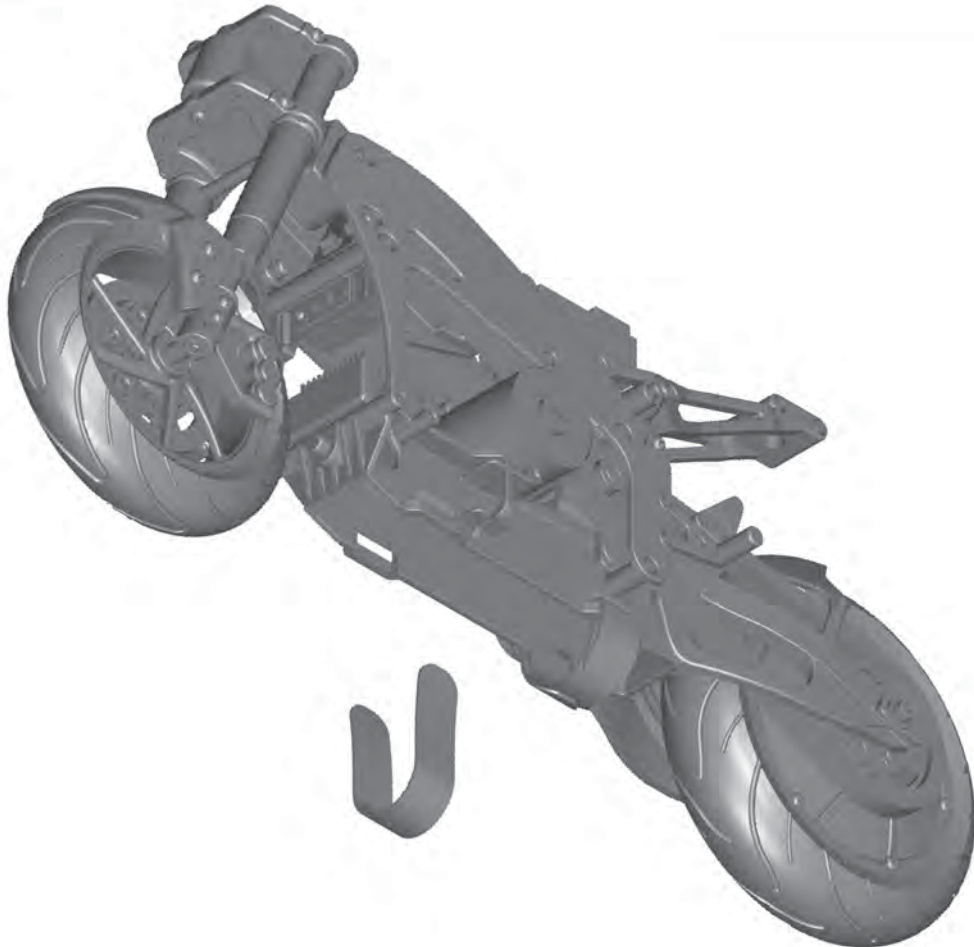
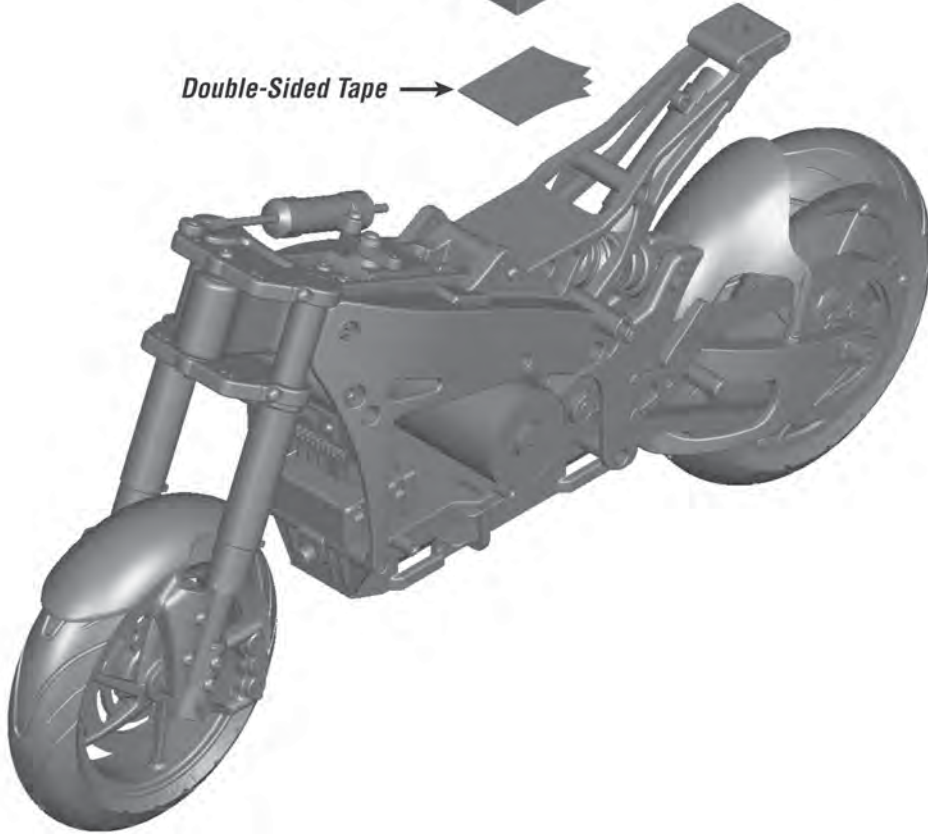

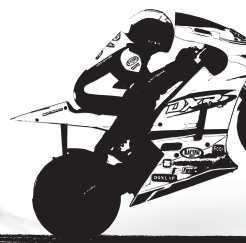
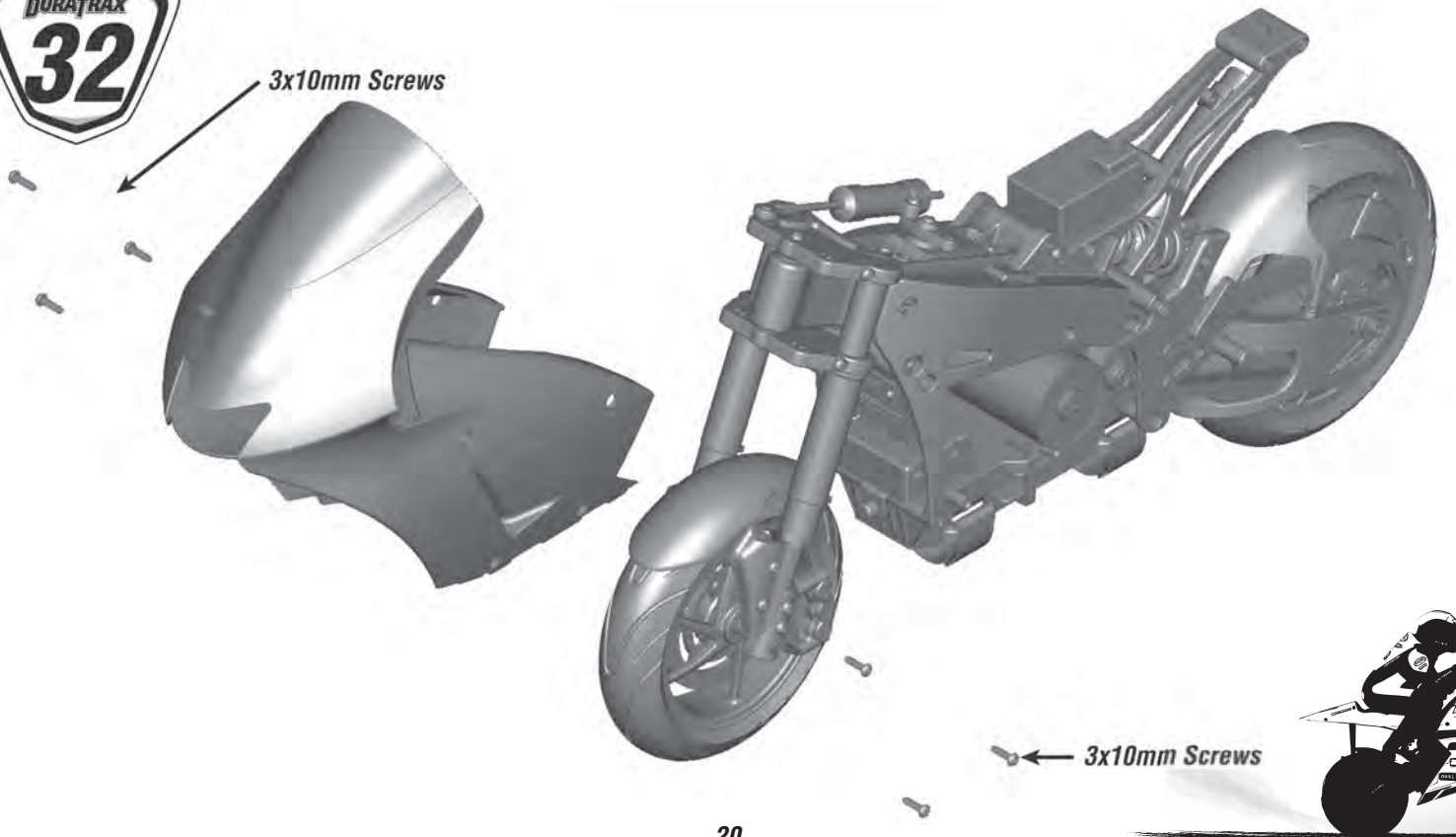
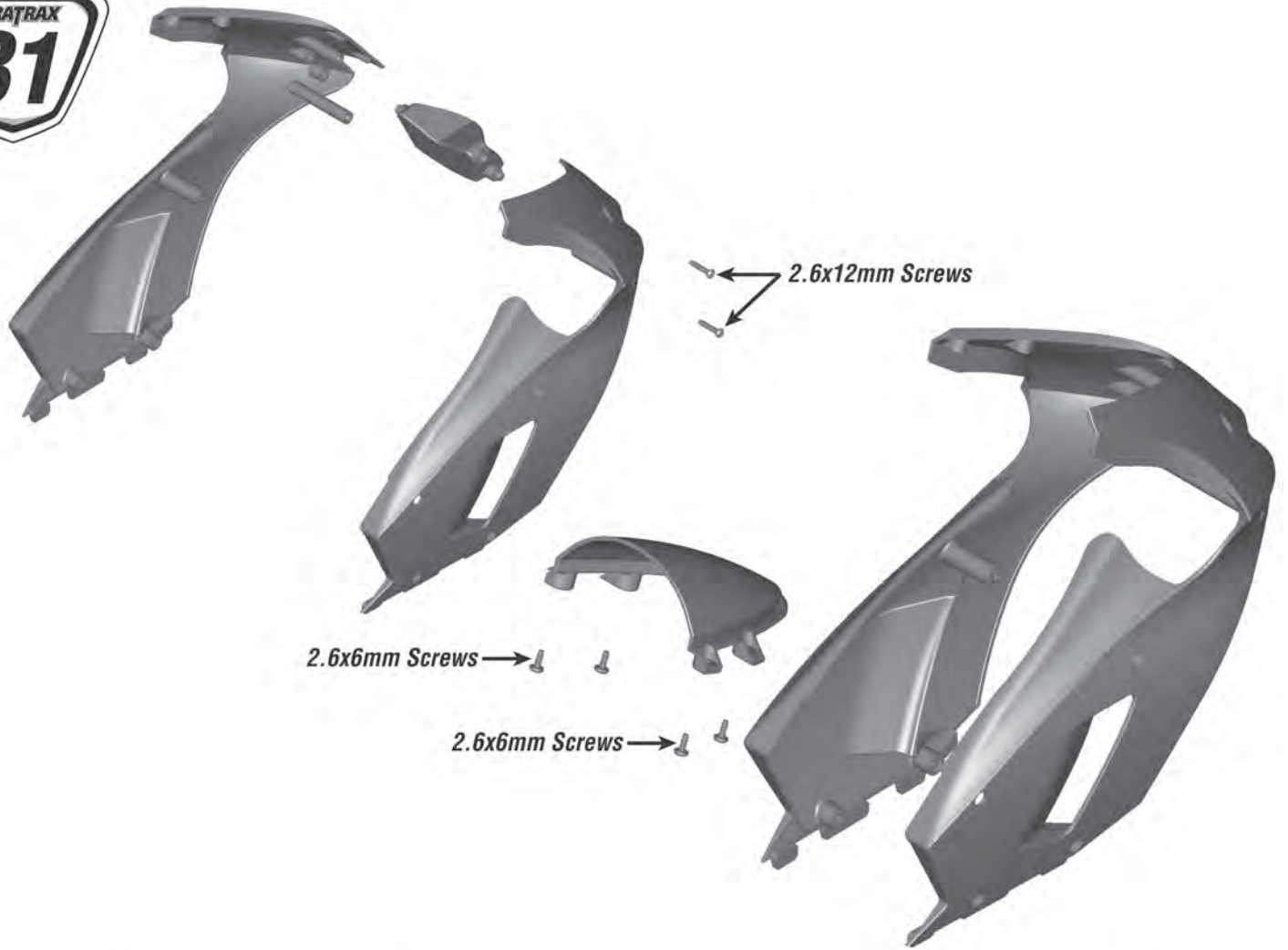

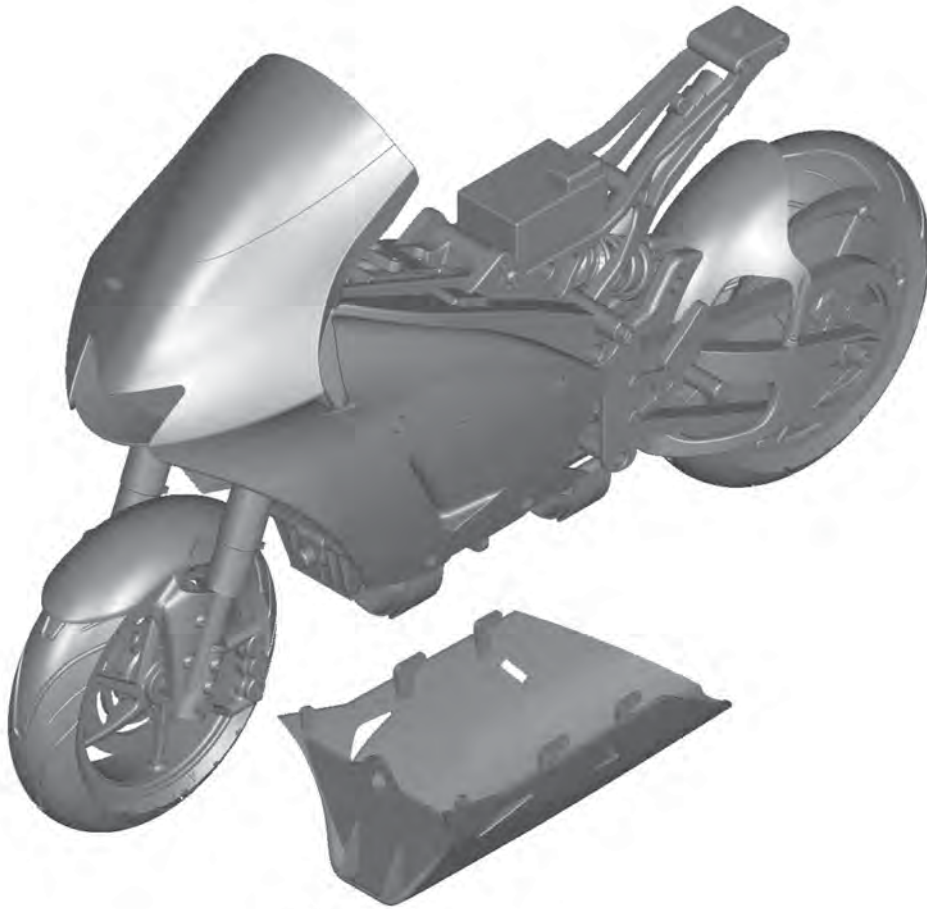

8

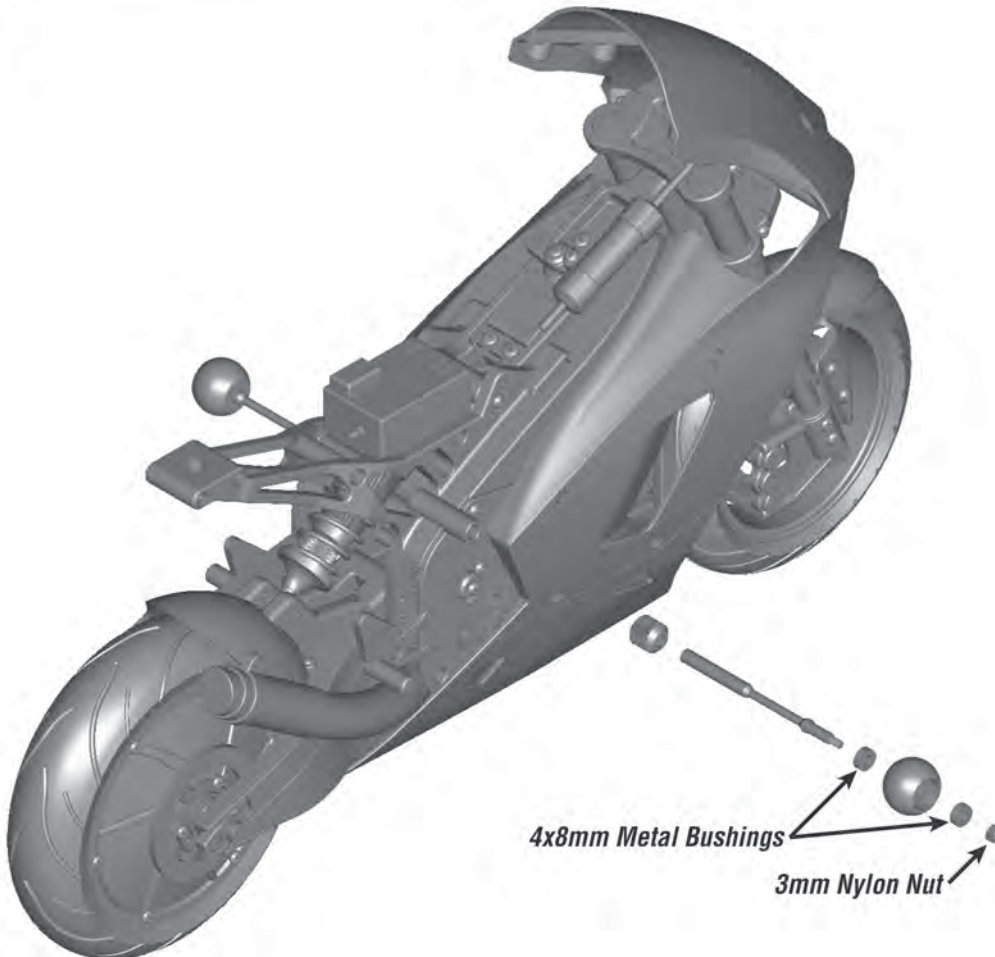

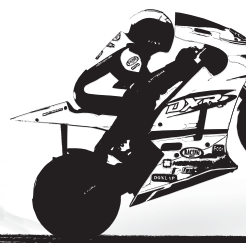
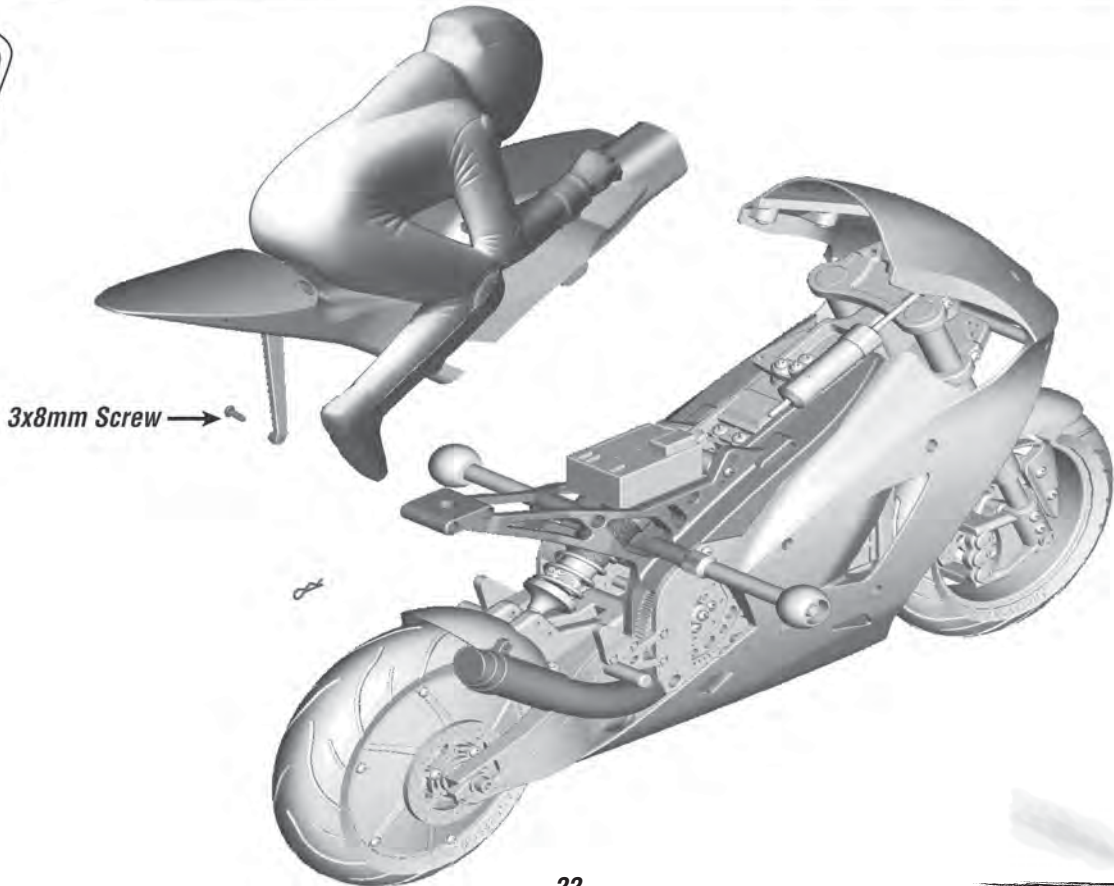
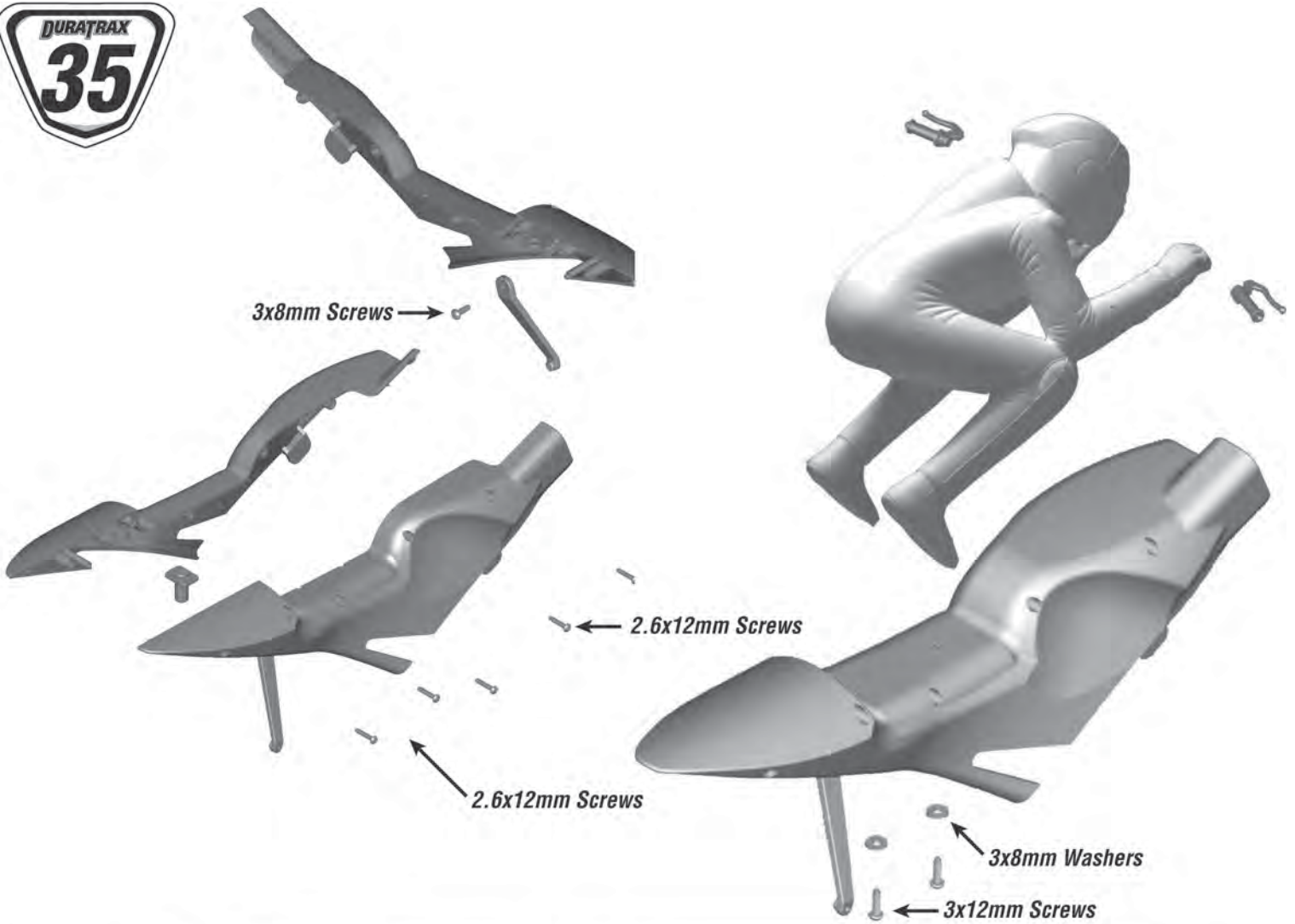

OTHER ITEMS AVAILABLE



**DuraTrax 1/18 Vendetta™ SC RTR
DTXD17****



**DuraTrax DX450
DTXD02****



**Heli-Max® Novus™ CX 2.4GHz
Nano Sized Coaxial RTF Heli
HMXE0803**



