

DLE-55RA

Operator's Manual

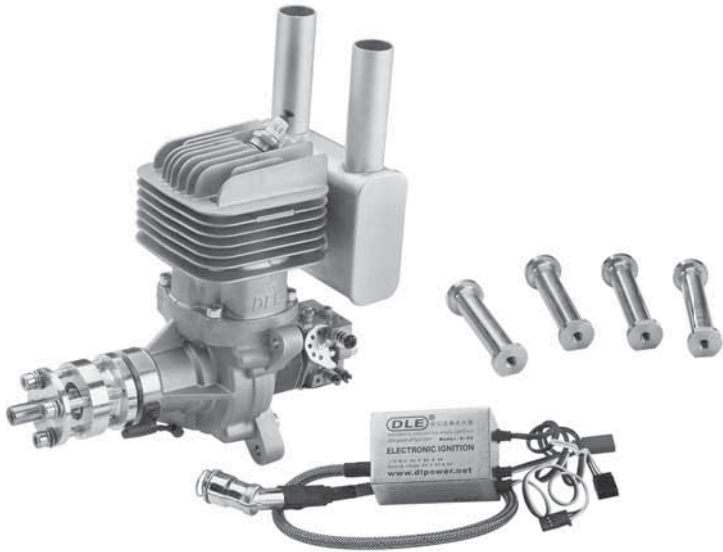

Specifications

Displacement: 55.6 cc [3.4 cu. in.]

Performance: 5.5 HP / 8,500 rpm

Idle Speed: 1,500 rpm

Ignition Style: Electronic Ignition

Recommended Propellers: 22×8, 22×10, 23×8, 23×10

Sparkplug Type: CM6

(Gap) 0.018 in. – 0.020 in. [0.45 mm – 0.51 mm]

Diameter × Stroke: 1.76 in. [45 mm] × 1.37 in. [35 mm]

Compression Ratio: 7.6:1

Carburetor: DLE with Manual Choke

Weight: Main Engine – 3.74 lb [1.33 Kg]

Muffler – 5.04 oz [143g]

Electronic Ignition – 5.39 oz [153g]

Engine Mount Standoffs – 4.51 oz [128g]

Fuel: 87 – 93 Octane Gasoline with a 30:1
gas/2-stroke (2-cycle) oil mixture

DLE™

Parts List

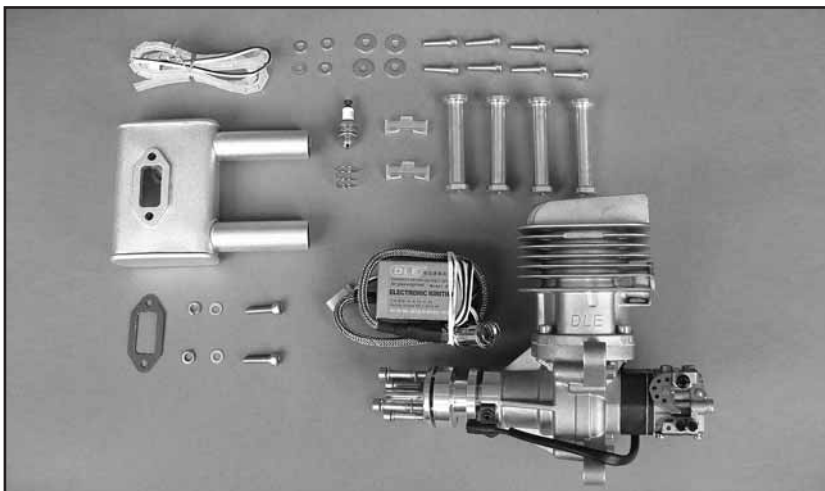

- (1) DLE-55RA Gas Engine w/carb
- (1) CM6 Spark Plug with spare ignition wire spring
- (1) Muffler w/gasket
- (2) 5x20mm SHCS (muffler mounting)
- (1) Electronic Ignition Module w/ additional tachometer lead
- (4) Engine Mounting Standoffs
- (8) 5x20mm SHCS with 5mm washers (mounting engine to standoffs)
- (4) 5x40mm SHCS with 5mm lock washers & flat washers (propeller mounting)
- (1) Silicone Pick-up Wire Cover / Ignition Wire Cover
- (1) Red Three Pin Connector Lead w/ Pig Tail (ignition switch)
- (2) Three Pin Connector Securing Clips
- (1) DLE Decal
- (2) 25x75mm White Exhaust Tubes with Clamps

Safety Tips and Warnings

- This engine is not a toy. Please place your safety and the safety of others paramount while operating. DLE will not be held responsible for any safety issues or accidents involving this engine.
- Operate the engine in a properly ventilated area.
- Before starting the engine, please make sure all components including the propeller and the engine mount are secure and tight. It is strongly recommended that a screw sealant is used (Great Planes® Threadlocker GPMR6060) during engine installation.
- During the break-in period, it is recommended that the engine be installed on the aircraft or a test stand with an appropriate shock absorber. Otherwise it is probable that vibration could rebound

back to the engine and serious damages may occur during the break-in period. Break-in should be considered about the first 3-5 gallons you run through the engine.

- For your safety and the safety of others, please do not stand in front of or in line with the propeller when the engine is running. Keep onlookers away from the running engine, especially small children.
- Always use a balanced spinner and a balanced propeller. An unbalanced spinner and propeller combination will cause high levels of vibration and may cause the propeller shaft to break. Always use a lightweight spinner on your engine. Lightweight spinners are considered to be those with a cone wall of 1mm or less. Heavy spinners could cause the propeller shaft to break. Securely tighten the spinner and propeller on the engine to prevent it from being thrown off the engine while running.
- Never use a propeller that has hit the ground. Even though it may look good from the outside, it may be cracked on the inside which may cause it to disintegrate while in use. Do not use a nicked, cracked or split propeller.
- Keep foreign objects away from the propeller. Make sure that nothing can be "sucked in" by the propeller.
- Never start the engine on loose gravel or sand.
- Do not attempt to stop the engine by throwing anything into the path of the propeller.
- Make sure the fuel line is well-secured to the engine and to the fuel tank so that it won't come off in flight.
- Do not use silicone fuel line because it will be dissolved by the fuel. Use gasoline approved vinyl or neoprene rubber fuel line. Always secure the fuel line away from the cylinder head. The engine's heat can damage the fuel line.
- Never touch the engine immediately after a run. The engine will be hot.
- Before transporting your model, remove all the fuel from the fuel tank and fuel lines.
- Always use high-quality oil intended for 2-stroke (2-cycle) engines. It's a good idea to use a petroleum-based 2-cycle motor oil like Lawn Boy All Season - Ashless oil for the break-in period.
- Do not install your throttle servo inside the engine compartment. Doing so could cause radio interference. Install all electronic radio devices at least 305mm [12"] away from the engine.
- The throttle and choke pushrods should be non-metallic.
- In case the engine is not to be used for more than a month, drain the fuel tank and remove any fuel from inside the carburetor. Do

this by running the engine at idle until it quits by running out of fuel. Keeping gasoline inside the carburetor over an extended period of time will damage the diaphragm valve and clog passages inside the carburetor. Because the carburetor is more complicated than those used in glow engines, keep the fuel clean by using a fuel filter. Use a filter intended to be used with gasoline engines. Metal filters intended for glow engines are too coarse and will not screen out finer particles.

- Always filter your fuel by using an appropriate filter before putting it into the airplane's fuel tank.
- Gasoline is extremely flammable. Keep it away from an open flame, excessive heat or sources of sparks.
- Do not smoke near the engine or the fuel tank.
- This engine was designed for use in a model aircraft. Do not attempt to use it for any other purpose.
- Always install an ignition system on/off switch on the aircraft used.
- **Caution:** Running the engine with a lean gas mixture will cause the engine to overheat and burn the electrode of the spark plug. Pay close attention to the High-Speed Needle adjustment. Running the engine with the proper gas mixture will make the spark plugs appear yellow at the ignition point.
- For optimum performance please use fresh or recently purchased 87–93 octane gasoline with a 30:1 gas/oil 2-stroke (2-cycle) mixture.

GAS/OIL Mixing Chart

1 Gallon Gasoline (128 fl oz/3.78L) / 2-Cycle Oil
(4.26fl oz/125.68ml) = 30:1 ratio

- Excessive running of the engine at idle speed can result in a seriously carbonized spark plug.
- Keep the surface of the engine clean to ensure proper heat dissipation.
- To avoid permanent damage to the electronic ignition system, NEVER rotate the propeller on your **DLE** engine with the electronic ignition system switched on and the plug not installed in the plug cap.
- If you choose to use the optional TX activated gas engine kill switch (DLEG9205) it is strongly recommended that you install the TX activated kill switch between the with a manual on/off switch and the ignition. The manual on/off switch provides an added safety feature in the event the TX activated kill switch does not function properly. This is especially important during the starting sequence as it requires the manual on/off switch to be in the ON position before ignition can occur.

Installation Instructions

Prepare the engine for installation

1. Check to see that all screws and bolts are tight. Check carefully for any cracks, broken, or missing parts. Tighten or replace any damaged or missing parts before proceeding.

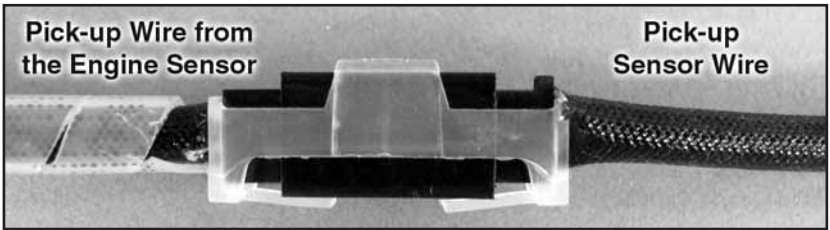
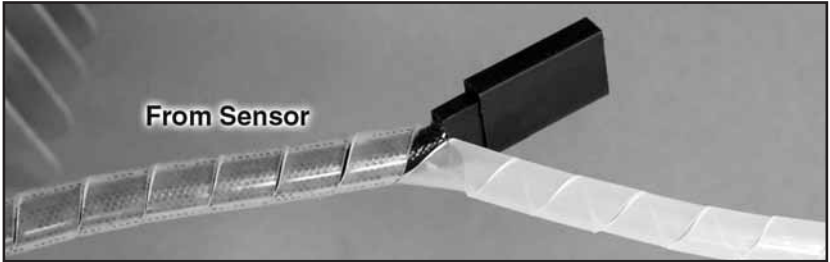

2. Install the silicone wire cover over the pick up lead coming from the motor (cut the excess silicone wire cover) and connect the lead to the pick-up lead from the Electronic Ignition Module. Secure the connection with the included three pin connector securing clip.

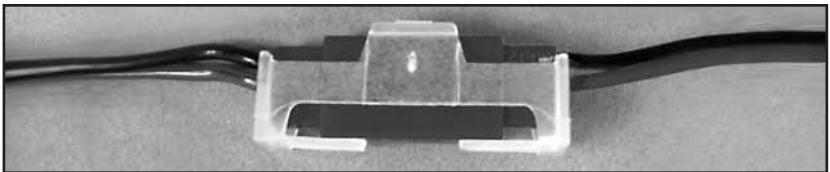
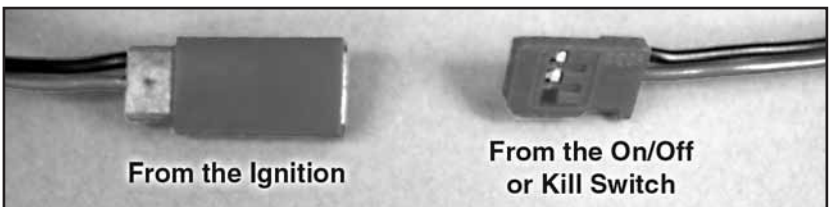

3. Connect the manual on/off switch lead to the red connector from the electronic ignition system using the lead from the kill switch or with the included three pin connector with pig tail. Use one of the included three pin securing clips to secure the connection.

4. Connect the ignition module battery to the kill switch. Any 4.8-8.4V, 1000mAh and above capacity battery will work well for this. Use heat shrink tubing to secure this connection. **Optional:** Install the TX activated gas engine kill switch (DLEG9205) between the manual on/off switch and the ignition as shown above. This is especially important during the starting sequence as it requires the manual on/off switch to be in the ON position before ignition can occur. The kill switch LED should be installed on the exterior of the aircraft so that it's visible from the front of the aircraft. This is to ensure that the person starting the engine is aware that the ignition is armed. If properly installed as shown above, an illuminated red LED indicates that that the ignition is armed.

5. Install the ignition on/off switch on the aircraft so that it is easily accessible through the cowling or the fuselage.



6. Install the ignition module and battery securely in the airplane forward area. It is recommended that a thin piece of foam rubber is placed between the module and the mounting surface and that Velcro® strap is used to hold the module in place.

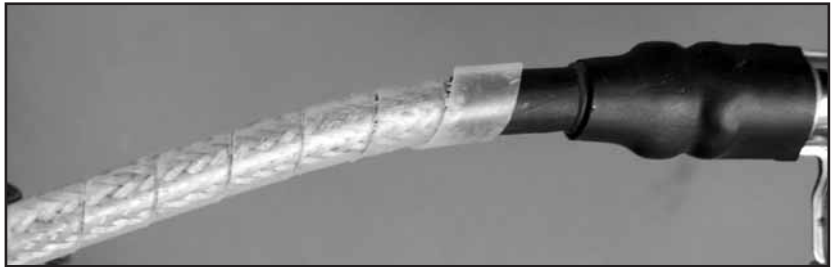

7. Install the remaining silicone wire cover over the ignition wire.

8. Install the spark plug into the engine head (7-8 lbs torque). Do not overtighten.

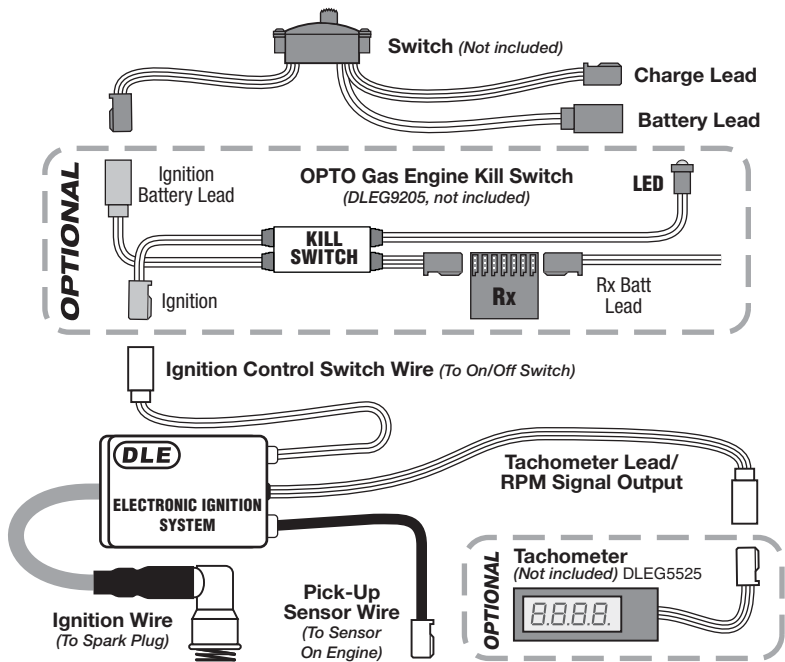

Installing the DLE-55RA on Your Airplane

Note: The DLE-55RA must be installed on at least a 9.5mm [3/8"] thick 5-ply plywood firewall. The firewall must be securely glued to the airplane. Use triangle stock and pin the firewall with hardwood dowels to reinforce the firewall glue joints. Never install the DLE-55RA onto a firewall thinner than specified because it may fail due to the power of the engine.

Note: The length of the engine from the back of the engine mount stand offs to the propeller drive washer is 6.73" [171 mm].

1. Use the supplied template (on the back cover of this manual) to drill the engine mounting bolt holes.

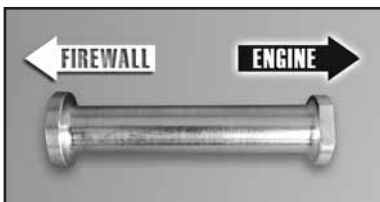

2. Install the standoffs to the firewall using (4) 5x20mm SHCS with 5mm lock washers and 5mm washers (not included) from the back side and through the firewall into the standoffs. Use some threadlocking compound,

such as Great Planes® Pro™ Threadlocker (GPMR6060), on the screws. Next install the DLE-55RA to the standoffs using the included (4) 5x20mm SHCS with 5mm washers. Be sure to also use threadlocker when mounting the engine to the standoffs.

3. Install the fuel tank in the airframe. Use only gasoline-safe fuel lines and a gasoline safe fuel tank stopper. One line should go to the carburetor and the other is to be used as a vent (a vent line is simply an open ended fuel line from the fuel tank which exits the engine compartment or the fuselage; most vent lines exit at the bottom of the firewall). You can fill the tank by using the carburetor line as fill line if you have access to it or install a third line to be used as fill line. Installing a third line is the cleanest and easiest way to add fuel. An alternative fueling set up is a 2-line system with a T-fitting approved for gasoline use. Be sure to use a filler plug with either a 2 line or 3 line set-up.

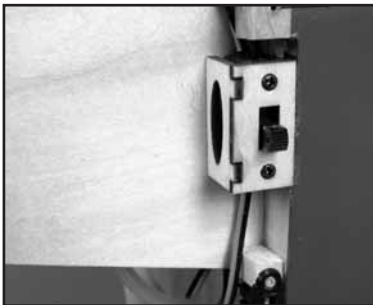
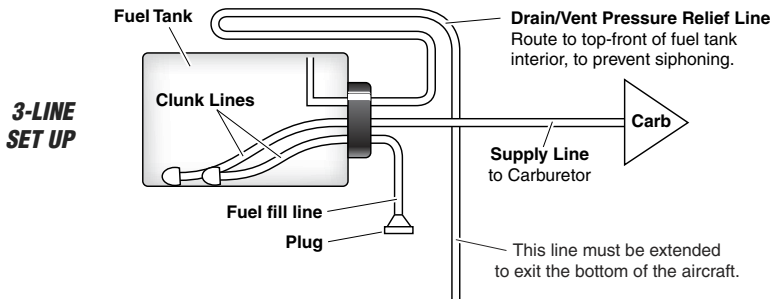
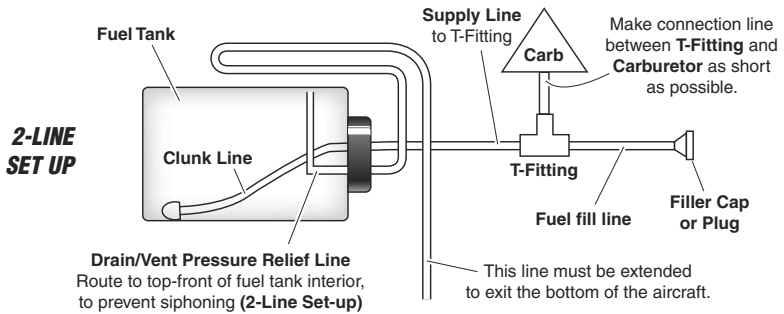

4. Install the manual on/off switch on the aircraft so that it is easily accessible from outside the plane.

5. Install the throttle servo at least 305mm [12"] away from the engine. Make sure that you get the carburetor's full range of rotation with your servo travel. Be sure to use a non-metallic linkage.

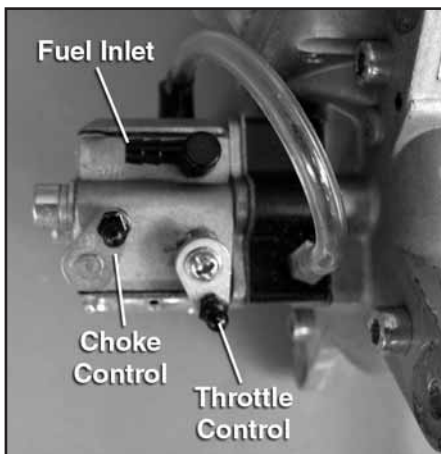
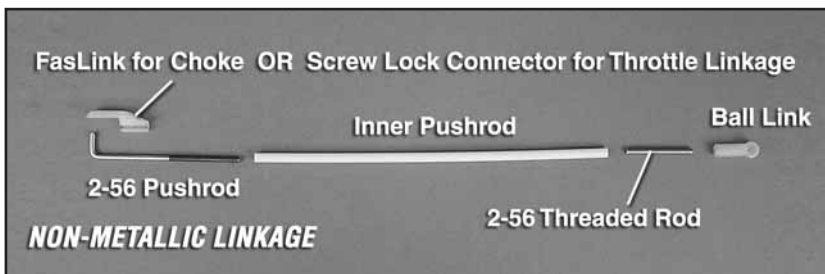

6. Install the choke servo (optional) at least 305mm [12"] away from the engine. Be sure to use a non-metallic linkage.

7. Install the ignition module securely in the airplane forward area. It is recommended that a thin piece of foam rubber is placed between the module and the mounting surface and that Velcro™ strap is used to hold the module in place.

8. Secure any unsecure connection with heat shrink tubing. (Not included.)

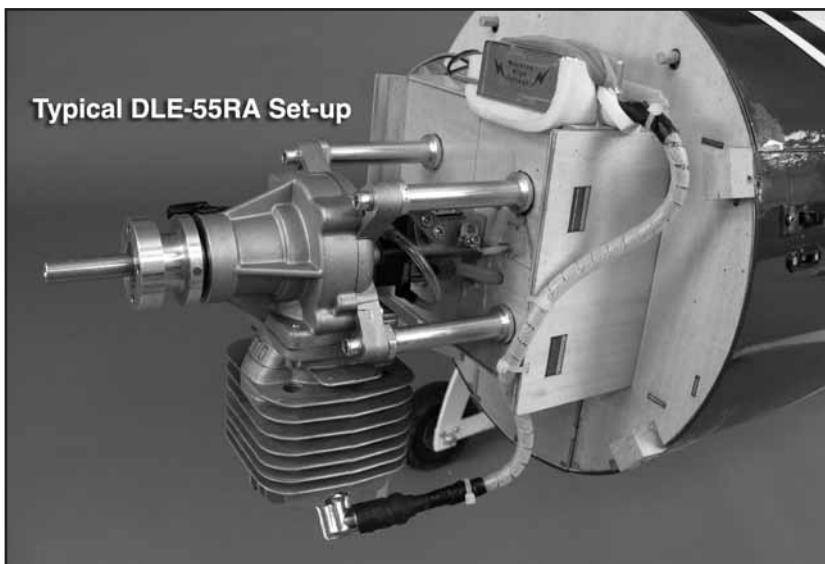

9. Connect the ignition wire from ignition module to the spark plug.

10. Install the muffler onto the engine. Be sure to use threadlocker.
11. Cut all necessary clearance, carburetor adjustment, cooling, and exhaust holes in the cowl.
12. Please ensure the sensor wire is supported as close to the sensor pick-up as possible. Flight loads may cause stress and damage to the wire where it enters the sensor body.
13. Make sure the cowl is secured to the airplane and that the spinner to cowl clearance is at least 3.2mm [1/8"]. If starting the engine the first time and during break-in it's recommended that you run the engine without the cowling.

Drill and Install the Propeller

The easiest way to drill the propeller to fit the hub is to use a drill guide. (DLEQ0551) If you do not have a drill guide, you can use the following method to drill your propellers.



1. Remove the cowling from the aircraft. Use the included propeller washer to mark the centering hole in the propeller.
2. Once the location is established, use a drill press with a #5 (.2055" / 5.21mm) drill bit as a pilot hole. Once the pilot hole is established, use a 13/32" (.406/10.31mm) drill bit to finish the hole. In order to achieve a clean opening on both sides of the propeller, drill only half way through the propeller with the finishing drill bit. Then flip the propeller over and drill completely through the hole.

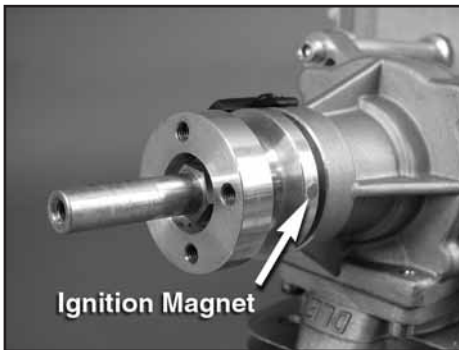

3. Next, set the engine at the beginning of the compression stroke. Note the position of the ignition magnet with engine inverted.

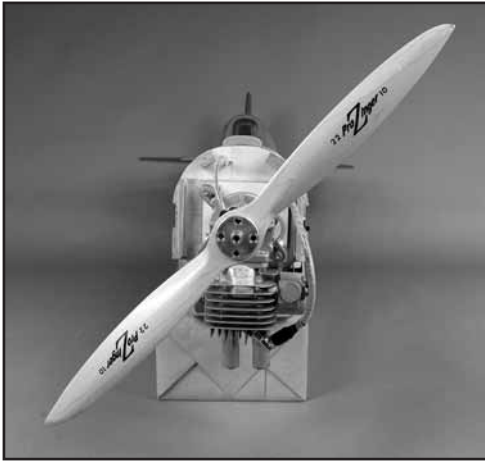

4. Place the propeller on the crankshaft at the 1 o'clock position.

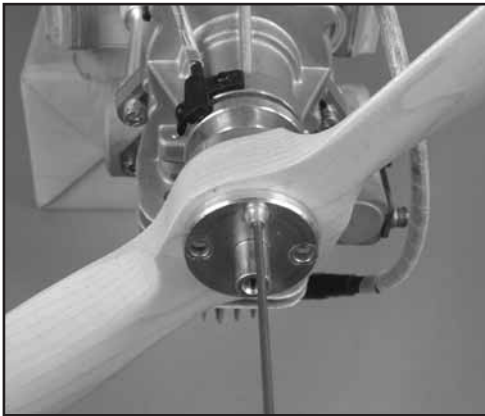

5. Mark the location of one of the outer holes while the propeller is in the top of the compression stroke position. Use a Dead Center Hole Locator (GPMR8130) to center and start the hole.

6. Remove the propeller from the engine and drill the outer hole on the drill press using a #35 drill bit as a pilot hole.

Next use a #5 (.2055" / 5.21mm) drill bit to finish the hole. In order to achieve a clean opening on both sides of the propeller, drill only half way through the propeller with the finishing drill bit. Then flip the propeller over and drill completely through the hole.

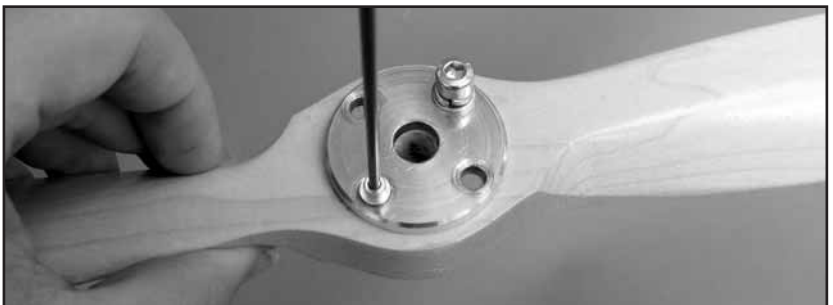

7. Use one of the 5x40mm SHCS with 5mm lock washers and 5mm flat washers to align the propeller washer on the propeller and use the Dead Center Hole Locator to mark position of the remaining holes.

8. Drill the remaining three holes in the propeller. In order to achieve a clean opening on both sides of the propeller, drill only half way through the propeller with the finishing drill bit. Then flip the propeller over and drill completely through the hole.

9. Mount the propeller to the engine using the 5x40mm SHCS with 5mm lock washers and flat washers. Be sure to use threadlocker.

Starting Procedures

There are two recommended ways to start the DLE-55RA:

A. Manual Starting

Note: When hand starting the DLE-55RA, use a thick glove or heavy duty starter stick to protect your hand.

1. The propeller should be installed on the drive washer so that it is at the one o'clock position and at the beginning of the compression stroke so that it is comfortable to flip it through compression.
2. Have someone help you hold the airplane while you start the engine.
3. Close the choke on the carburetor and open the throttle slightly from the idle position.
4. Switch on, or power your radio system and make sure you have control of the throttle visually at the carburetor. Also make sure that the reversing position of the servo is correct at the transmitter and that the throttle is at the minimum position.
5. Switch the ignition to ON. If you installed the optional TX activated gas engine kill switch (DLEG9205) properly between the manual on/off switch and the ignition make sure that the TX switch assigned is in the on position. The LED should be illuminated red to indicate that the ignition is armed.
6. Flip the propeller *counter clockwise* several times briskly.
7. After you hear some initial firing sounds, move the choke lever to the OPEN position.
8. Set the throttle to a high idle. Set the propeller so that it's at the beginning of the compression stroke
9. Flip the propeller through compression rapidly. If this is done properly, the engine will start after several brisk flips of the propeller.

10. After starting, let the engine idle for 30 to 45 seconds. Open and close the throttle slowly until the engine runs smoothly at idle and at full throttle. Acceleration should also be smooth. If acceleration is not smooth adjustments to the carburetor may be necessary. (See **Adjustment of the Engine** on page 14.)
11. If your engine does not start, repeat steps 6 through 10.

B. Electric Starter Starting

1. A 24 volt electric starter is recommended to start the DLE-55RA. Make sure you use a high quality, lightweight aluminum spinner.
2. Have someone help you hold the airplane while you start it.
3. Close the choke on the carburetor and open the throttle slightly from the idle position.
4. Switch on, or power your radio system and make sure you have control of the throttle visually at the carburetor. Also make sure that the reversing position of the servo is correct at the transmitter and that the throttle is at the minimum position.
5. Switch the ignition to ON. If you installed the TX activated gas engine kill switch (DLEG9205) properly between the manual on/off switch and the ignition make sure that the TX switch assigned is in the on position. The LED should be illuminated red to indicate that the ignition is armed.
6. Using the starter, turn over the engine till popping sound is heard. Next, open the choke.
7. Use your electric starter to turn over the engine until it starts.
8. After starting, let the engine idle for one to two minutes. Open and close the throttle slowly until the engine runs smoothly at idle and at full throttle. Acceleration should also be smooth. If acceleration is not smooth, adjustments to the carburetor may be necessary. (See **Adjustment of the Engine** on pages 10–12.)
9. If your engine does not start, repeat steps 6 and 7.

Engine Troubleshooting

If your engine fails to start after the preceding starting procedures please check the following.

Symptom	Diagnosis	Fix
Engine does not fire	Ignition battery low	Charge or replace battery
	Battery wires faulty	Replace wires or Re-connect/check connections
	Faulty spark plug or not firing	Replace spark plug or check for spark *
	Engine flooded	Remove plug, rotate prop to remove fuel
Engine starts, then rpm increases till engine cuts out	Fuel not reaching engine	Check for: a) fuel in tank b) fuel tubing cut, blocked, or kinked c) carburetor clogged

* This can be done by removing the spark plug from head of the engine and contacting the plug on the outside of the crank case. Have an assistant turn the engine over while checking this and be sure to have the spark plug firmly plugged into the ignition wire. Warning the high voltage from the ignition can cause bodily harm, especially when checking for spark in this manner.

Adjustment of the Engine

Each DLE Engine has been factory preset. However, elevation changes will influence the performance of the carburetor. To obtain optimum output of the engine, slight adjustment of the carburetor maybe necessary. Also, for safety reasons do not make adjustments to the carburetor while the engine is running.

Engine Functions and Adjustments

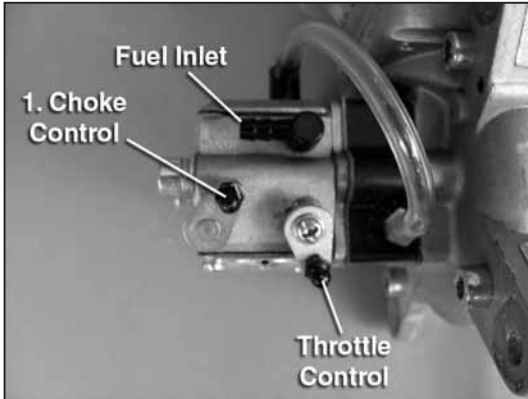

1. Choke Control

(the choke should be used when the engine is cold)

2. Throttle Stop

3. Idle Adjustment Screw (adjust the idle speed)

4. (L) Low-Speed Needle (adjusts the fuel/air mixture at low speeds)

5. (H) High-Speed Needle (adjusts the fuel/air mixture at high speeds)

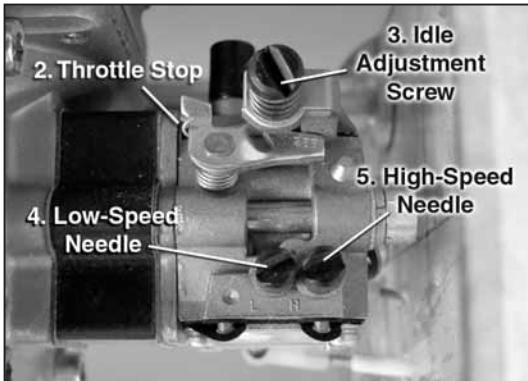

Idle Adjustment

Turning the Idle Adjustment Screw (No.3) clockwise will increase the idle speed. Turning the Idle Screw counter-clockwise will decrease the idle speed.

Low Speed Needle Adjustment

Turning the Low-Speed Needle (No.4) clockwise will lean the fuel/air mixture at low speeds. Turning the Low-Speed Needle (No.4) counter-clockwise will richen the fuel/air mixture at low speeds. (The default or factory setting of the Low-Speed Needle is as follows; turn the needle to the fully stop/closed position and then open the needle 1.25 turns.)

High Speed Needle Adjustment

Turning the High-Speed Needle (No.5) clockwise will lean the fuel/air mixture at high speeds. Turning the High-Speed Needle (No.5) counter-clockwise will richen the fuel/air mixture at high speeds. (The default or factory setting of the High-Speed Needle is as follows; turn the needle to the fully stop/closed position and then open the needle 1.5 turns). It is recommended that the High-Speed Needle be adjusted by the use of a tachometer to obtain maximum speed.

Smooth acceleration and deceleration is an indicator of proper engine performance.

Ignition Timing Adjustment

The ignition timing is preset on the DLE-55RA at 44° before Top Dead Center (TDC). The ignition timing can be advanced or retarded by loosening the (2) ignition sensor phillips head screws and sliding the sensor to the full extent clockwise (45° advancing the ignition) or counter clockwise (43° retarding the ignition). Be sure to retighten the Phillips head screws after adjusting the ignition timing.

Advancing the timing causes combustion to occur earlier resulting in higher performance of the engine. However, advancing the timing also causes higher engine temperatures and can cause premature wear of internal engine components.

Carburetor Adjustment Troubleshooting

Problem

1. The engine hesitates when accelerated rapidly.
2. The rpm increases at idling.
3. The engine stops when the throttle is moved from high to low.

Solution

The low-speed needle "L" is too lean. Open it about 1/8 of a turn and try again.

Problem

The idle is not steady.

Solution

The low-speed needle "L" valve is too rich. Close it 1/8 of a turn and try again.

Problem

1. Engine stops at full throttle.
2. Engine hesitates when accelerated rapidly.
3. The engine will not come up to full rpm at full throttle.

Solution

The high-speed needle valve "H" is too lean. Open it 1/8 of a turn and try again.

Problem

1. The engine does not reach full rpm.
2. Carbon build-ups appear consistently on your spark plug.

Solution

The high-speed needle valve "H" is too rich. Close it 1/8 turn and try again.

Optional Mini Tachometer

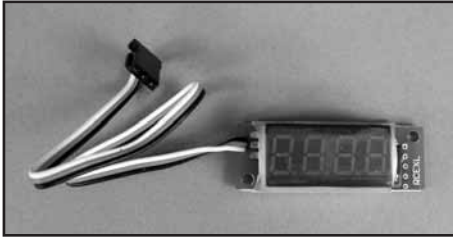

An optional Digital Tachometer (DLEG5525) is available that can be directly connected to the ignition and display the RPMs of the engine. This unit can be installed on the aircraft or used to spot check the Engine RPMs. Do not install

or uninstall the Digital Tachometer while the engine is running.

Many of the DLE Ignition modules have an additional lead to plug into the optional tachometer. If your ignition module does not have this additional lead, the digital tachometer can still be used. Simply use the included Y-harness (included with the Digital Tachometer) to connect to the pick-up lead from the engine. Be sure to secure all connections and to secure the Digital Tachometer or leads on the aircraft used.

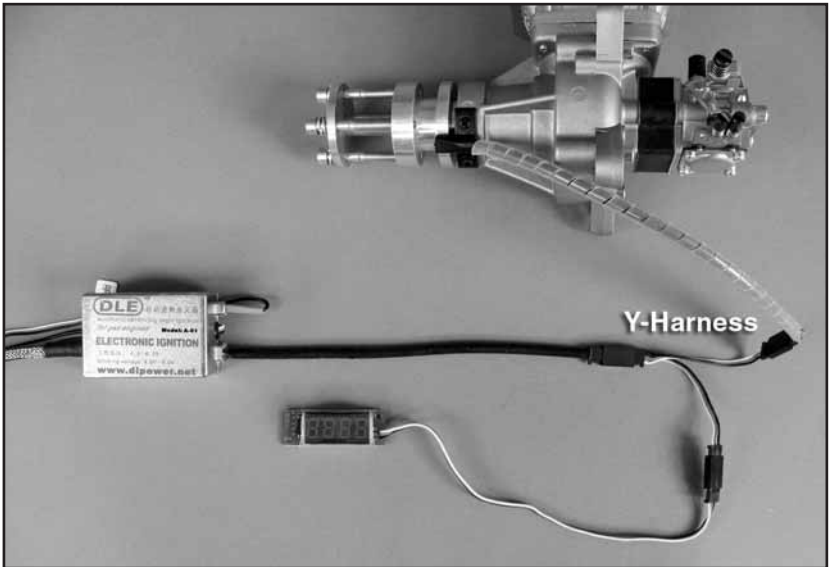

Engine Maintenance

Please clean the fuel filter in the carburetor periodically. Failure to do so may result in mis-calibration of the needle adjustments. In order to do this it is necessary to remove the phillips head screw which secures the carb filter cover and the carb filter gasket. Use only carburetor cleaner to clean the opening around the filter.

Phillips Head
Screw

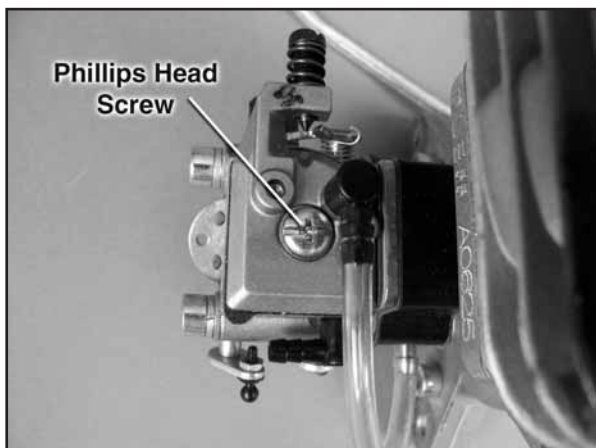

Carburetor
Gasket

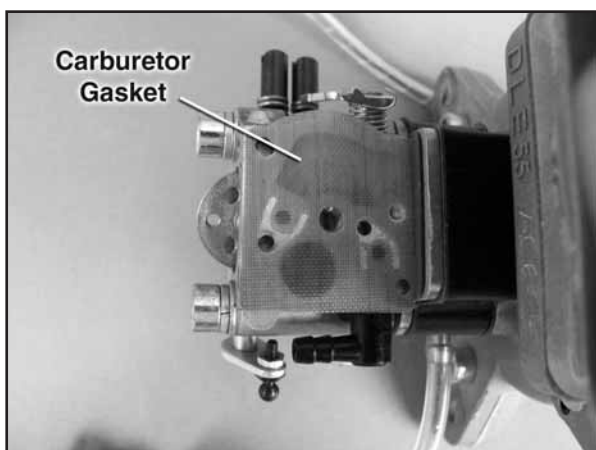

Fuel
Filter

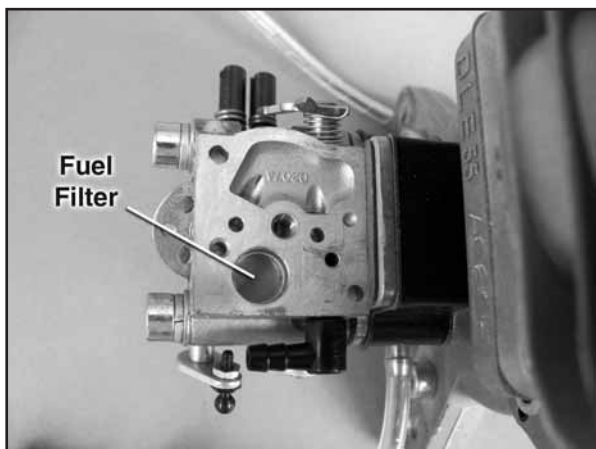

Warranty Information

The DLE-55RA has a two year limited warranty through Hobby Services beginning at date of purchase.

Contact Us

Hobby Services

3002 N. Apollo Drive Suite #1
Champaign, IL 61822

Ph: 217-398-0007
Fax: 217-398-7721

E-mail: hobbyservices@hobbico.com
Web address: www.hobbyservices.com

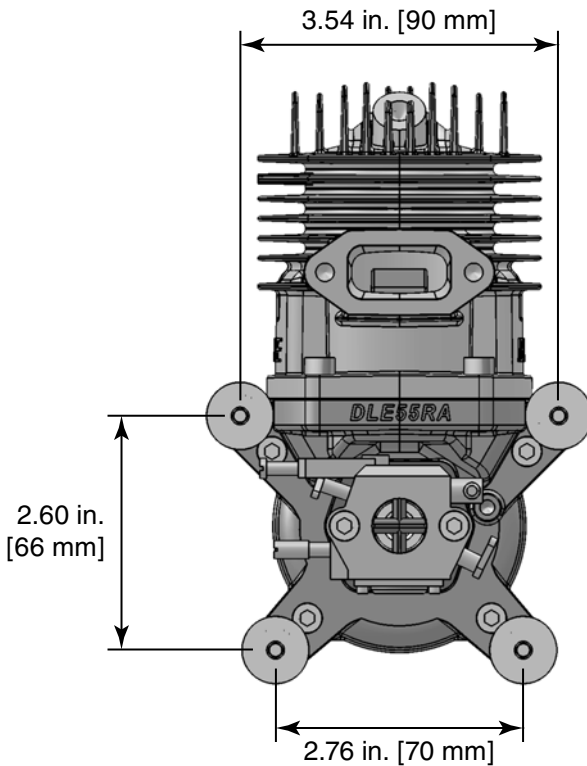

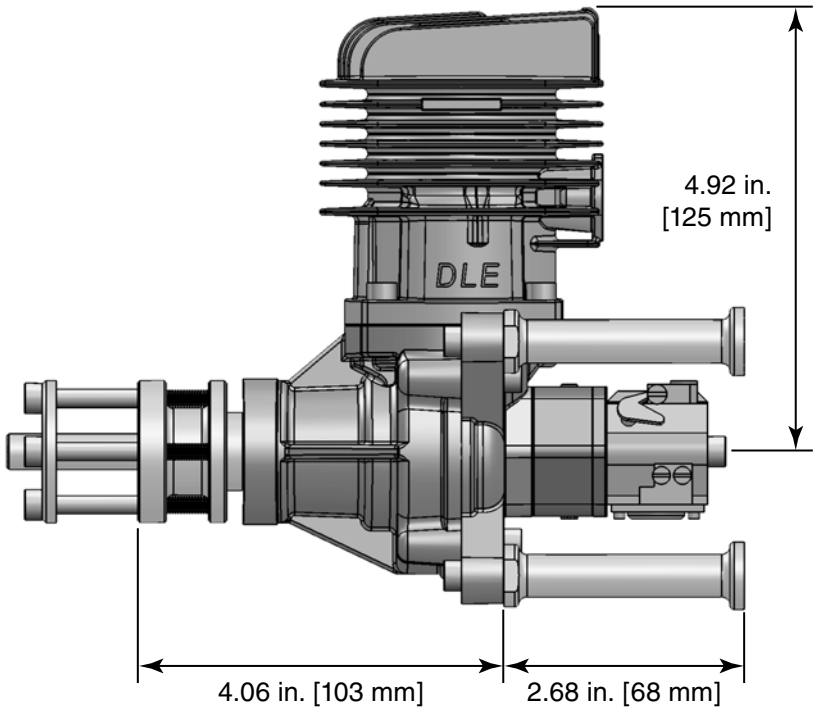

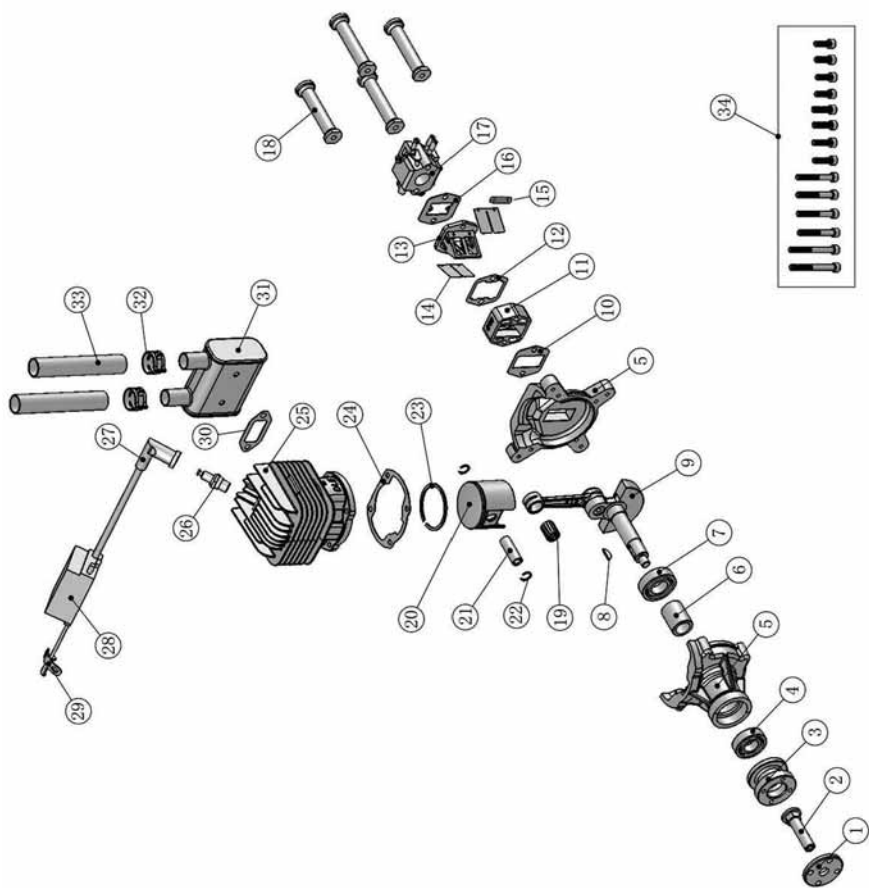

Replacement Parts

Key No.	Stock No.	Mfg Stock No.	Description
1	DLEG5701	55RA-N1	Propeller Drive Washer
2	DLEG5702	55RA-N2	Propeller Drive Nut
3	DLEG5703	55RA-N3	Propeller Drive Hub
4	DLEG5704	55RA-N4	Bearing Front
5	DLEG5705	55RA-N5	Crankcase
6	DLEG5706	55RA-N6	Crankshaft Spacer
7	DLEG5707	55RA-N7	Bearing Rear
8	DLEG5708	55RA-N8	Woodruff Key
9	DLEG5709	55RA-N9	Crankshaft
10	DLEG5710	55RA-N10	Gasket Set
12			
16			
24			
30			
11	DLEG5711	55RA-N11	Carburetor Heat Block
13	DLEG5713	55RA-N13	Reed Valve
14	DLEG5714	55RA-N14	Reed Valve Petal
15	DLEG5715	55RA-N15	Reed Valve Plate
17	DLEG5717	55RA-N17	Carburetor Complete
18	DLEG5718	55RA-N18	Engine Mount Standoff
19	DLEG5719	55RA-N19	Needle Bearing
20	DLEG5720	55RA-N20	Piston w/Pin
21	DLEG5721	55RA-N21	Piston Pin
22	DLEG5722	55RA-N22	Piston Pin Retainer
23	DLEG5723	55RA-N23	Piston Ring
25	DLEG5725	55RA-N25	Cylinder
26	DLEG5726	55RA-N26	Spark Plug
27	DLEG5727	55RA-N27	Spark Plug Cap
28	DLEG5728	55RA-N28	Electric Ignition
29	DLEG5729	55RA-N29	Ignition Sensor
31	DLEG5731	55RA-N31	Muffler
32	DLEG5732	55RA-N32	Exhaust Clamp
33	DLEG5733	55RA-N33	Exhaust Tube
34	DLEG5734	55RA-N34	Screw Set

Optional Parts (not shown)

DLEG5525	Onboard Digital Tachometer
DLEG9205	Gas Engine Kill Switch v2.0
DLEQ0551	Prop Drill Guide (55, 55RA, 60 Twin)

DLE-55RA Mounting Pattern

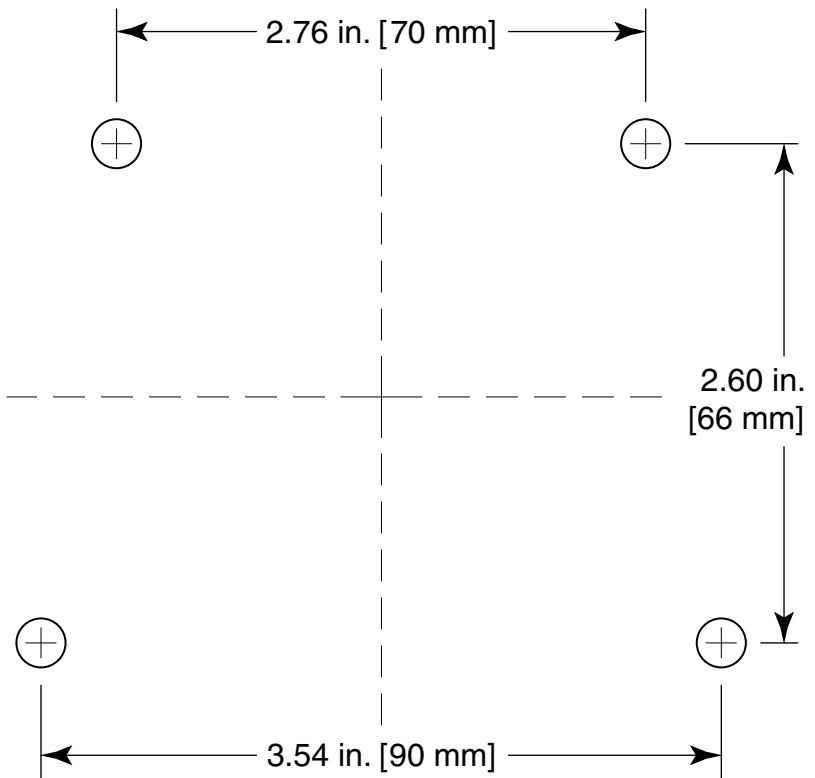

DLE