



Warranty

- **AquaCraft™** will warrant this motor for 90 days after the purchase from defects in materials or workmanship. AquaCraft will either repair or replace, at no charge, the incorrectly made part.
- Make sure you save the receipt or invoice you were given when you bought your motor! It is your proof of purchase and we must see it before we can honor the warranty.
- To return your EP1 for repairs covered under warranty you should send your motor to:

Hobby Services

3002 N Apollo Drive Suite 1

Champaign, IL 61822

Attn: Service Department

Phone: (217) 398-0007 9:00 am - 5:00 pm Central Time M-F

E-mail: hobbyservices@hobbico.com

INTRODUCTION

Thank you for purchasing the AquaCraft EP1! We at AquaCraft know how exciting a new hobby purchase can be and we know you're anxious to get started, but please take time to read these instructions carefully and completely before attempting to operate your motor. This manual contains the instructions you need to safely operate and maintain your motor. As with any hobby, there is the possibility of injury. Arming yourself with knowledge is the best way to avoid injury.

PLEASE NOTE: Your hobby dealer cannot accept a return on the EP1 outboard unit after it has been used.

SPECIFICATION & DESCRIPTION CHANGES

All pictures, descriptions, and specifications found in this instruction manual are subject to change without notice. AquaCraft maintains no responsibility for inadvertent errors in this manual.

EP1 INSTALLATION

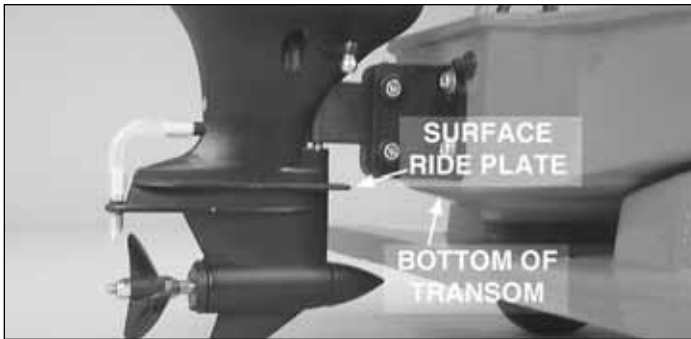

A template has been provided for you on page 3 of this manual. This will help to accurately place the mounting holes. Mount the outboard unit in the center of the rear of the boat and so that the surface ride plate is even with the bottom of the transom as shown.

STEERING LINKAGE

The steering control arms of the EP1 outboard unit have been outfitted with 4.8mm balls, but will accept clevis or Z-bend links as well. You can attach to either control arm or both but it is best, of course, to do whichever makes your boat perform to its fullest potential.

BASIC MAINTENANCE

When you are through operating your boat for the day, be sure to perform these basic maintenance procedures. This will prolong the life of the EP1 Outboard motor and help to ensure trouble-free running. **Be sure to turn the power "OFF" to your boat and transmitter before performing any maintenance.**

- Flip your boat over and shake any excess water from the motor compartment.
- Locate and remove the "end cap" (see "**Exploded View**" on page 4) at the base of the outboard by turning it counterclockwise. This will allow you to release any water trapped in the gear housing. The "bullet" at the front of the outboard unit is also removed by counterclockwise rotation. This allows access to the front shaft bearing.
- Make sure the propeller and drive dog are free of moss.

REGULAR MAINTENANCE

After every 10-12 hours of leisurely run time or after a day of competition, it is a good idea to disassemble and re-lubricate the gears, shafts, and bearings of the outboard unit with fairly heavy-duty grease (not oil). Be sure to wipe away any old grease but **DO NOT** use any de-greasing agents. Refer to the "**Exploded View**" on the back cover for an assembly diagram.

GETTING MORE OUT OF YOUR EP1

You can increase the performance of the AquaCraft EP1 by adjusting the ride height or the thrust angle of the propeller. Making slight adjustments can make major differences, so it is a good idea to keep a record of any adjustments you make and how they affect performance. In addition to these adjustments, performance may also be affected by the weight distribution of your onboard radio gear, speed control, battery pack(s), etc...

GO FASTER

The EP1 comes equipped with a 27-turn stock motor but can be upgraded by replacing it with almost any 550-can size motor. Be sure to consult the instructions for your speed control unit to determine motor upgrade limits.

1. After clipping or de-soldering the red (+) and black (-) motor wires, simply remove the two 3 x 8mm hex head screws on the underside of the motor compartment and gently lift out the stock motor. Be sure to remove the water-cooling coil and jacket from the stock motor and place it on the upgrade motor before installation.
2. Solder the red (+) and black (-) motor wires to the proper wiring lugs and attach the upgrade motor to the outboard unit with the two 3 x 8mm hex head screws.

SAFETY PRECAUTIONS

PLEASE READ BEFORE running the EP1 on your model:

- **NEVER** attempt to swim after a stalled or capsized boat! Wait patiently for the wind currents to return the boat to

shore or use a tennis ball attached to the end of a fishing rod to retrieve a stalled or capsized boat.

- It is dangerous to operate any R/C model at any time that there is not sufficient light.
- R/C models produce vibrations which *will* cause screws, nuts, bolts, etc, on your model to become loose over time. **It is important to make sure that all hardware is secure** before operating your model.
- **The edges of the propeller are very sharp and can cut your fingers** if you are not careful. At no time should you ever attempt to stop the prop with your hand. In the event that weeds become entangled in the propeller, turn the EP1's power "OFF" before attempting to remove them.
- Total run time of the EP1 can vary depending upon what battery pack and ESC combination you are using. When you notice a decrease in power or sluggish steering response, it means the battery pack is nearly drained and it's time to head for shore. As soon as the boat reaches shore, turn off the power to the boat's receiver and transmitter (in that order).
- **CAUTION: Your motor and battery may be hot!** Allow them to cool for a few minutes before attempting to remove the battery pack.
- Adult supervision is strongly recommended! Children should be warned about the dangers of playing in close proximity to water.
- R/C boats are controlled by radio signals, which are susceptible to possible interference from other R/C transmitters, paging systems, or other electrical noise. **Before turning your radio transmitter and receiver on**, make sure no one else in the area is operating a radio on the same frequency (channel).
- Do not touch the propeller anytime the electronics are turned "ON." **Pay close attention** to items such as loose clothing, shirt sleeves, ties, scarves, long hair or any loose objects that may come in contact with the spinning propeller. If your fingers, hands, etc. come in contact with the spinning propeller, you may be severely injured.
- The speed and mass of R/C boats can inflict property damage and severe personal injury if a collision occurs. **Never run an R/C boat in the presence of swimmers** or where the possibility of collision with people, wildlife, or property exists.
- Electric motors can generate considerable heat. **Do not touch any part of your motor** until it has cooled. Touching the motor immediately after running the boat may result in a serious burn.

the EP1 immediately in new and unused condition to the place of purchase.

ORDERING REPLACEMENT PARTS

To order replacement parts for the AquaCraft EP1, use the order numbers in the **Replacement Parts List** that follows. Replacement parts are available only as listed and can be purchased from hobby shops or mail order/Internet order firms. Hardware items (screws, nuts, bolts) are also available from these outlets. If you need assistance locating a dealer to purchase parts, visit www.hobbico.com and click on "Where to buy." If this kit is missing parts, contact Hobbico Product Support.

Replacement Parts List

Order #	Item	Description
HCAB7861	EP1 Outboard Motor Unit	*This is the part number for the entire unit.
HCAB6457	Outboard Upper Cover	#1
HCAB7857	Outboard Lower Unit	#2
HCAB7750	Propeller Set	#16,17,18,19 x2
HCAB7856	Ball Bearings	#G x4
HCAB3479	Motor	#3
HCAB7858	Motor Coupler & Gasket	#6, A, #7
HCAB8100	Transom Mount	#22, C x2, D x2
HCAB7801	Linkage Ball Studs & Linkages	#23 x2, E x2, F x2
HCAZ3023	Instruction Manual	

Hardware Listing

- A. 3 x 3mm Set Screw
- B. 3 x 8mm Hex Head Screw
- C. 3 x 16mm Hex Head Screw
- D. 3mm Nylon Insert Locknut
- E. 2mm Nut
- F. 2 x 8mm Screw
- G. 5 x 10mm Ball Bearing

OUTBOARD MOTOR TEMPLATE

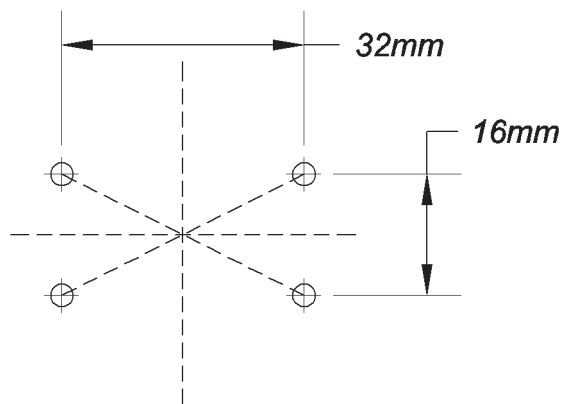

If the buyer is not prepared to accept the liability associated with the use of this product, the buyer is advised to return

EXPLODED VIEWS

