









GP-1 ULTRA

INSTRUCTION MANUAL

WARNING

-  Never attempt to swim after a stalled R/C boat.
 -  Never operate your R/C boat while standing in the water.
 -  Never operate your R/C boat in the presence of swimmers.
 -  Always use a Personal Flotation Device (PFD) when boarding and operating your retrieval craft, i.e. Jon boat or duck boat. NOTE: Because of the sharp running hardware included with this R/C boat, we do not recommend a rubber blow up raft.
 -  R/C boat running hardware is very sharp. Be very careful when working on and around the metal parts.
 -  While the motor is running, pay close attention to the propeller. Do not come in contact with the propeller at any time the engine is running or serious injury will result.
 -  AquaCraft products are to be used by ages 14 and over.
-

Introduction

THANK YOU FROM AQUACRAFT

Thank you for purchasing the AquaCraft GP-1 Ultra Hydroplane. We want the time you spend with your new R/C boat to be fun and successful, so please fully read the manual. If, for any reason you think this model is not for you, return it to your local dealer immediately. **NOTE: Your hobby dealer cannot accept a return on any model after final assembly or after your boat has been operated.**

All pictures, descriptions, and specifications found in this instruction manual are subject to change without notice. AquaCraft maintains no responsibility for inadvertent errors in this manual.

Items Included



- GP-1 Ultra Mini
- Tactic™ Transmitter
- Boat Stand
- Hatch Tape
- Extra Prop
- Extra Rudder O-ring

Parts Needed to Complete Your Model

- 1 - ElectriFly® 11.1V 1000mAh 30C LiPo Battery (GPMP0830)
- 1 - ElectriFly 3S LiPo AC/DC Balancing Smart Charger (GPMM3318)
- 4 - AA Dry Cell Batteries
- 1 - HIGHLY RECOMMENDED ElectriFly SafeCharge™ LiPo Battery Charge Bag (GPMP0751)

OTHER BATTERY AND CHARGER CHOICES

Battery

- ElectriFly 11.1V 1200mAh 30C LiPo Battery (GPMP0836)

Charger

- Duratrax® Onyx™ 235 AC/DC Advanced Balancing Charger (DTXP4235)

RECOMMENDED OPTIONAL PARTS AND TOOLS

- GrimRacer Speed Grease Drive Cable Lube (AQUB9500)
- Duratrax Ultimate Hex Driver 1.5 mm (DTXR0288)
- Duratrax Ultimate Hex Driver 2.0 mm (DTXR0289)
- Duratrax Ultimate Hex Driver 2.5 mm (DTXR0290)
- Duratrax Precision Nut Driver 5.5x75 mm (DTXR0212)
- GrimRacer Pro Radio Box Tape (AQUB9514)
- Electrify CellMatch 2S-6S Balancing Meter (GPMM3210)

Important LiPo Performance and Care Information!

To get the most performance and safety from your LiPo battery, please read and understand the following information.

CHARGING

Always follow the manufacturer's recommendation for charging and maintaining your batteries. Please take extra care while operating an R/C boat.

For best performance and longest battery life, never charge your LiPos at a charge rate higher than 1C. (1000mAh = 1amp). It's best to remove the battery pack from the model and charge in a safe containment system like a LiPo Sack (GPMP0751) or other safe charge container when charging.

DISCHARGING OR OPERATION

We have found it best to use only 80% of the rated mAh of the battery pack per discharge (boat run). Your battery's performance will decrease if you continue to discharge your packs below 80%.

In normal operation you will find your GP-1 Ultra Mini Hydroplane will use around 200 to 225mAh per minute of operation. On rough water, your GP-1 Ultra Mini Hydroplane will use around 180 to 200mAh per minute. Keep this in mind as you adjust your run times.

NOTE: Your AquaCraft GP-1 Ultra Mini Hydroplane has a stutter bump warning system that warns you of low battery voltage. This system starts its warning at or around 9.6V, giving you time to bring the boat back to shore before the cutoff at 9V. This is a built-in safety system for you, your boat and your batteries. Although this system is in place, we still recommend adjusting your run times to not exceed 80% battery usage.

STORAGE

Store your battery pack/s in a LiPo Sack (GPMP0751) or other battery containment device. It is also best to store them in a cool dry place and on a fire resistant surface. It is best to charge your batteries to either a full charge (if you feel you will be using the packs frequently) or at 11.4V for a 3S pack (or 3.8V per cell) for longer storage.

Warranty Service

AquaCraft® will warrant your GP-1 Ultra Mini Hydroplane for 90 days after purchase from defects in materials or workmanship of original manufacture. AquaCraft, at their discretion, will repair or replace the incorrectly made part at no charge. This warranty does not cover damage caused by crashes, abuse, misuse, alterations or accidents. To return your boat for repairs, you need to provide proof of purchase; your store receipt or product invoice will suffice. **IN NO EVENT SHALL THE PURCHASER BE ENTITLED TO ANY INCIDENTAL, SPECIAL, INDIRECT OR CONSEQUENTIAL DAMAGES, WHETHER RESULTING FROM THE USE, MISUSE OR INABILITY TO USE THE PRODUCT OR FROM DEFECTS IN THE PRODUCT.** This warranty gives you specific legal rights. You may also have other rights, which vary from state to state.

Outside the USA and Canada, contact your local importer for warranty information.

HOBBY SERVICES Ph: (217) 398-0007
Attn: Service Department 9:00 am - 5:00 pm
3002 N. Apollo Drive, Suite 1 Central Time M-F
Champaign, Illinois 61822

E-mail: hobbyservices@hobbico.com

Safety Precautions

- **Never ever attempt to swim after a stalled R/C boat. Do not get in the water for any reason to retrieve your boat. To aid in retrieving a stalled R/C boat, set up a fishing reel with a tennis ball tied to the end of the line. Better yet, get yourself a small Jon boat so you can row out and pick up your boat. Remember to use a PFD any time you enter your retrieval craft.**
- AquaCraft products are to be used by ages 14 and over.
- Do not touch the propeller anytime the motor is running. Pay equally close attention to items such as loose clothing, shirtsleeves, ties, scarves, long hair or anything that may become entangled in the spinning prop. If your fingers, hands, etc. come in contact with the spinning propeller, you may be severely injured.
- The speed and mass of this boat can inflict property damage and severe personal injury if a collision occurs. Never run this boat in the presence of swimmers or where the possibility of collision with people or property exists.
- Electric motors produce heat. Do not touch any part of your motor until it has cooled.
- This boat is controlled by radio signals, which are susceptible to possible interference from other possible electrical noise.
- In the event that weeds become entangled in the propeller, stop the motor before attempting to remove them.
- If your boat should happen to stall, water currents will slowly carry it to shore. Keep in mind that the boat could be carried to the opposite shore. When surveying areas to run your

boat, keep variables in mind such as wind direction, and lake size. It is not advisable to run R/C boats on any free-flowing bodies of water such as creeks or rivers.

- Always remove the battery pack from the boat before charging.

Specifications

GP-1 ULTRA MINI HYDROPLANE BOAT SPECIFICATIONS

Hull length: 16.4" [416 mm]
Overall length: 18" [458 mm]
Width: 8.8" [222 mm]
Height: 4" [102 mm]
Weight: 14.4oz [408 grams] (less battery)
Run time: 4 to 6 minutes

BOAT FEATURES

- ◆ Tactic TTX240 2.4GHz transmitter with TR324 receiver
- ◆ 2200 kV brushless inrunner motor with aluminum water jacket
- ◆ LiPo-ready (3S) 30 Amp brushless water-cooled motor controller with low battery warning system and battery cut-off circuit
- ◆ Tough, lightweight ABS construction with square hatch opening for easy taping
- ◆ Great-looking, pre-applied GP-1 graphics

OTHER FEATURES

- ◆ Adjustable strut
- ◆ Music-wire drive shaft
- ◆ Pinch wire motor coupler
- ◆ Break-away wedge rudder
- ◆ One-piece aluminum turn fin
- ◆ 1/8" [3.2mm] prop shaft
- ◆ Two blade 30mm FRP propeller
- ◆ Transom drain plug

MOTOR

KV rating: 2200 kV @ 11.1V
Operating current: 1.4A, 8V/DC
(without loading)
Input: 8 to 14V
Max current: 28A/15 Seconds
Shaft diameter: 3.2 mm (1/8")
Motor resistance: 50 mΩ
Dimensions: 27.5 × 30 mm (1.1" × 1.2")
Weight: 71 grams (2.5 oz)

MOTOR CONTROLLER

Rated Current: 30 amp
Battery Connector: Deans® Ultra Plug®
Motor Connector: 3.5 mm Bullet Plugs
Wire Gauge: 14G
Warning System: 9.6V Stutter Bump
LVC: 9V
BEC Max Current: 2A
PWM: 8K
Dimensions: 1.8" × 0.9" × 0.4"
(45 mm × 24 mm × 9 mm)

Understanding Your Transmitter

To help you better understand your transmitter and its functions, here is a picture outlying the operation features.

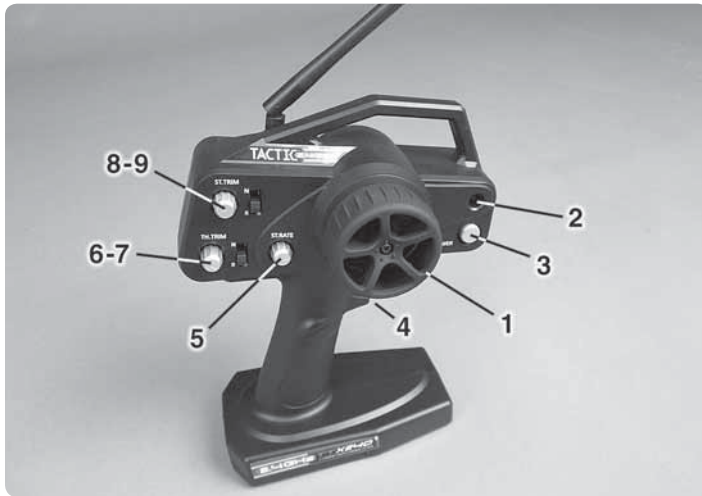

- 1 **Steering Wheel**
- 2 **LED Power Indicator**
- 3 **Power ON/OFF Button**
- 4 **Throttle Trigger**
- 5 **Steering Rate Adjustment** (this is used to increase or decrease the turning radius of the boat)
- 6 **Throttle Reversing Switch** ("R" is the position the switch needs to be in for your GP-1 Ultra Mini Hydroplane)
- 7 **Throttle Trim Dial** (this should be in the 12:00 to 3:00 o'clock position for your GP-1 Ultra Mini Hydroplane)
- 8 **Steering Trim** (this is used to adjust the tracking of the boat)
- 9 **Steering Reversing Switch** (this should be in the "R" position to operate your GP-1 Ultra Mini Hydroplane)

Assembly Sequence

INSTALLING THE TRANSMITTER BATTERIES



Slide off the battery door from the bottom of the transmitter.



Install 4 "AA" batteries into the transmitter in the configuration molded into the battery floor and reinstall the battery door.



Turn the transmitter on by pressing the "Power" button on the right side of the transmitter. The battery indicator light (LED) should glow red. If the light is flashing, the batteries are low and need to be replaced.

INSTALLING THE BATTERY PACK



Remove the canopy by lifting at the back and rotating up off the front pins.

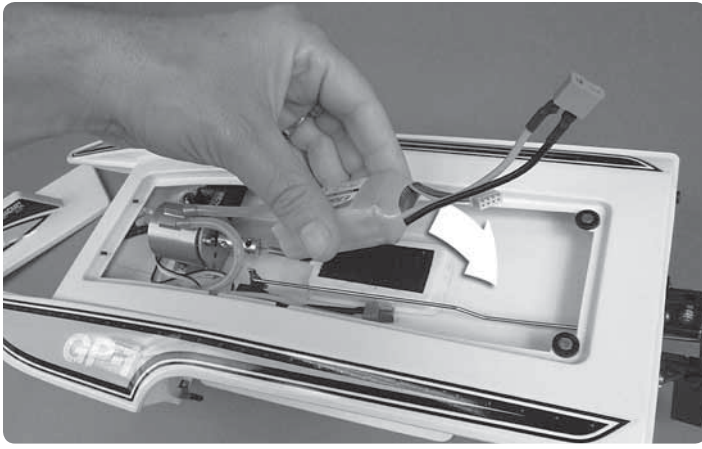

In your boat, you will find a length of hook and loop material on the battery tray. Remove the piece of hook and loop and install on to the battery's back. Install the battery into the boat as shown.

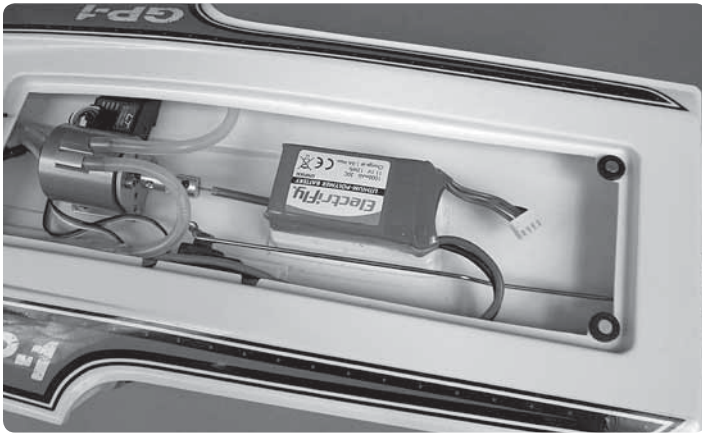

Tuck the wires neatly under the decking.

ARMING

With the transmitter on, plug a charged battery into the controller. You will hear the motor chime, plus one beep letting you know the motor has power. Squeeze the throttle trigger fully and you will hear two more beeps. Relax the throttle trigger and you will hear three beeps, the boat is now armed and ready to run. (Note: The arming procedure has to be done each time you plug the pack into the boat.)

LET'S REVIEW THE ARMING PROCEDURE

Plug the battery in; you will hear a chime with a beep. bee-daa-beep--beep!

Squeeze the throttle trigger fully, you will hear two beeps. "beep-beep".

Relax the throttle trigger; you will hear three more beeps. "beep-beep-beep".

The boat's power system is now armed and ready to run.

Place the canopy on the boat, sliding the front pegs into the cowl. The back will be held by the small magnets. Your boat is now ready for operation. It is best to tape the canopy closed. Tape is the best system for keeping water out of your boat. We have supplied you with a small roll to get you started. You can also upgrade to our Premium Radio Box Tape, making application and removal much easier. (GrimRacer Pro Radio Box Tape AQUB9514)

RECEIVER READY (Rx-R) RADIO INSTALLATION

Listed here are a few great radios to choose from for your receiver-ready (Rx-R) GP-1 Ultra Mini.

- 1. Tactic™ TTX240 (TACJ0245)** The TTX240 radio system is reliable and easy to operate. It's basic, but has all the necessary features to operate your GP-1.
- 2. Futaba® 3PM-X (FUTK2021)** This radio system is very reliable and offers more operator options. We really like the timer option this radio system offers, as well as the multi model memory.
- 3. Futaba 4PL (FUTK1400)** Along with great reliability this radio system offers the most user options. It's also a great system if you want to add to your AquaCraft boat collection. This system offers 40-model memory and 10-character naming – great features to grow your boat lineup.

NOTE: This step will require working on the boat with the radio and motor turned on. To prevent injury, temporarily remove the propeller from the boat.

Mount your receiver in your boat by installing hook and loop to the bottom of your receiver. Install the receiver to the right of the motor.

Plug the steering servo into channel 1 of the receiver and the motor controller into channel 2.

Turn on your transmitter.

Set the Throttle Trim to negative (clockwise if you have a dial) 25%.

If your radio has end point adjustments, check to see that your EPA is set to 100% (both forward and reverse) throttle trigger. Then proceed to "arming".

Launching and Driving Your GP-1 Ultra Mini Hydroplane

Place the boat in water that is at least 12" (305 mm) deep. Make sure the water is free of weeds, sticks or other floating debris.

Your GP-1 Ultra Mini Hydroplane is designed to turn right. It's also important to note this boat is FAST! Having said this, it is best to be quite aggressive with the throttle to overcome any cavitation that the boat might encounter as it starts to move forward. It's also a good idea to run in a larger pond. Do not run your GP-1 Ultra Mini Hydroplane in a pool.

After you have completed a run, it is best to FIRST unplug the boat's LiPo battery. This safely powers down the boat before turning off your transmitter.

IMPORTANT: If your boat takes on a large amount of water and stalls, don't worry, **foam flotation will keep it from sinking.** You will have to retrieve the boat and remove the canopy to release any water that might have entered. If the inside is flooded, remove the transom plug from the back of the boat and let the water drain. Allow the boat to fully dry before operating it again. Remember to re-install the transom plug before running.

Maintenance



It is important to remove and re-lubricate the driveshaft after running for the day. Make sure the battery pack is unplugged. You will need a 2mm hex wrench, GrimRacer Cable Grease and some paper towels.



Using a 2mm hex wrench, loosen the screws holding the drive cable to the motor coupler. It is important to note that there are two set screws holding the shaft in position.



Slip the driveshaft out the back of the boat. Wipe off any grease and water that might be on the shaft.



Using GrimRacer Speed Grease, apply a small amount to the shaft and slide it back into the boat. Be careful to align the driveshaft to the hole in the end of the motor coupler.

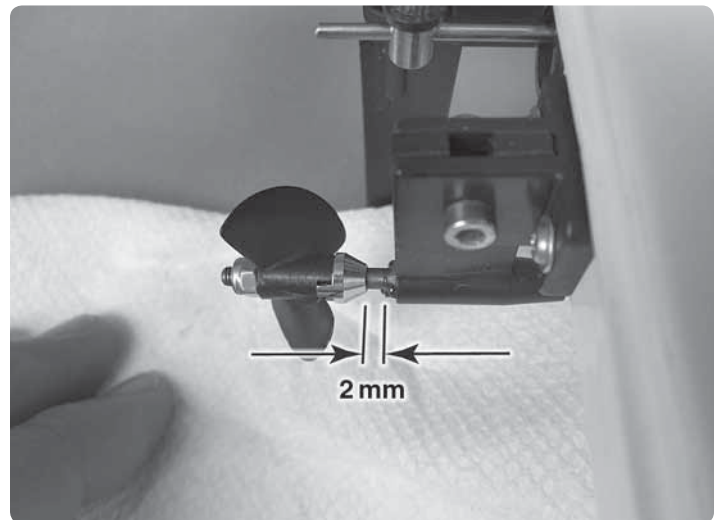

Leave about a 1/16" [2mm] gap between the front of the drive dog and the back of the brass tube. Retighten the shaft coupler screws.

Performance Tuning

Keep in mind, as you tune your GP-1 Ultra Mini Hydroplane for top speed and handling that this boat IS SMALL AND FAST! Because of its size it only needs very small adjustments to change the way it performs.

STEERING DEFLECTION

Your GP-1 Ultra Mini Hydroplane has VERY aggressive steering. It's important to keep this in mind as you tune your boat. The rudder only needs a small amount of deflection to turn well. Setting the rate knob to high (Clockwise) can upset the handling. Ultimately, it needs to be tuned to your race course or liking.

SHARPENING

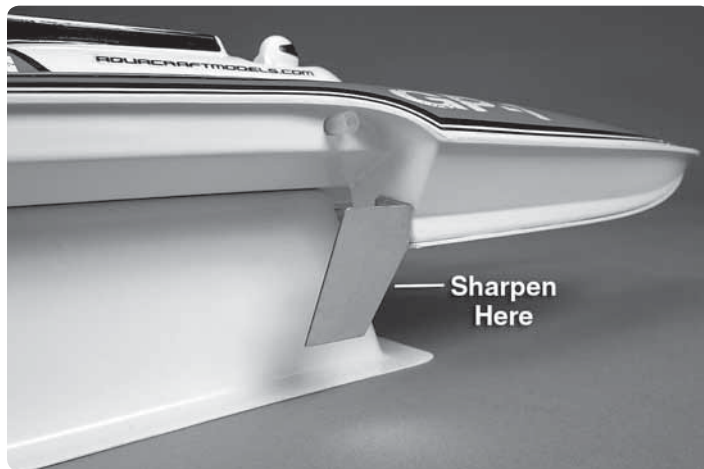

It's best to sharpen the turn fin to a razor-sharp edge. This will eliminate drag and reduce lift. Remember as a rule of thumb, if it touches the water, it needs to be sharp or have sharp edges. GRIMRACER SAYS! Sharpen the outer edge of the turn fin toward the inside of the boat. This is a great way to help control prop torque.

STRUT

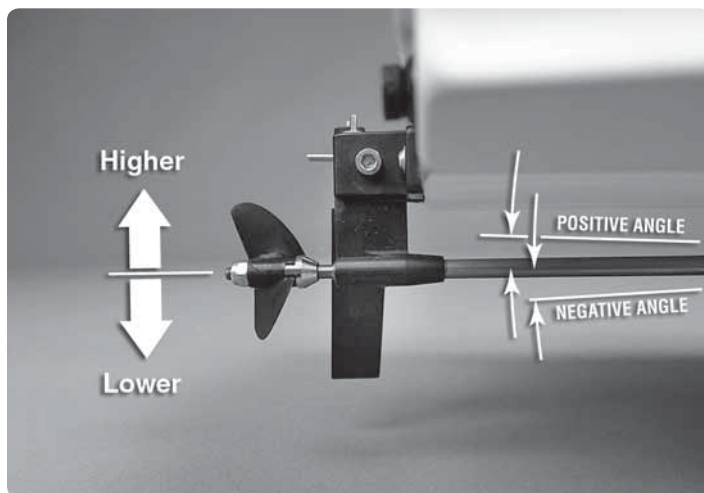

The strut can be *tweaked* to change the ride of the boat but only experienced modelers should attempt this. If you are going to *tweak* the strut remove the prop shaft and prop. Loosen the strut bolt. Move or adjust the strut, taking care not to lose the

alignment of the driveshaft to the motor coupler. If needed, you might have to re-bend this area to regain alignment.

Racing

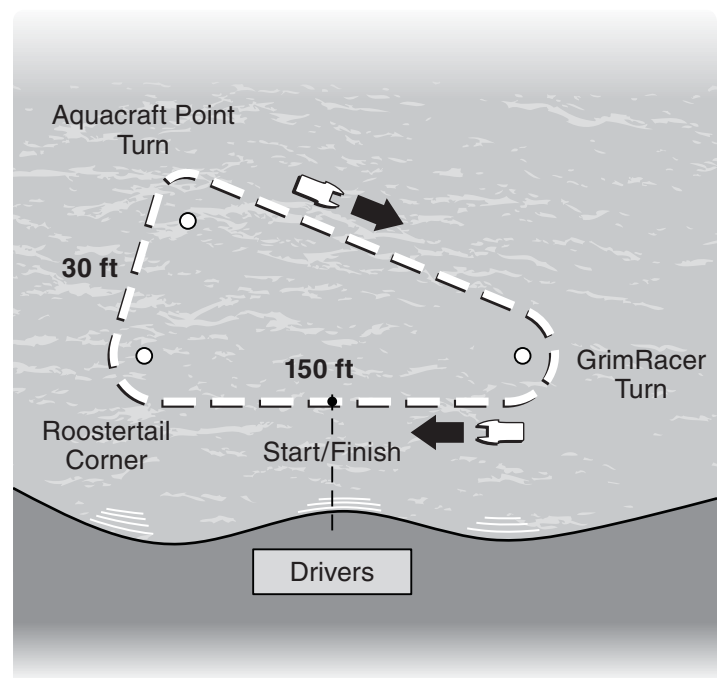

GP-1 ULTRA MINI HYDROPLANE RACING RULES

Boats must remain stock. Only hardware adjustments are allowed. Sharpening and scuffing are legal, but changing a prop is not. You are also allowed to paint or add decals if you choose.

A heat race is 6 laps and typically consists of up to 6 boats per heat. You can run as many heats per event as you like, but 3 to 5 is typical.

To start a race, set a timer to 30 seconds. Launch the boats and make one full clockwise lap. At the end of the lap, you need to be on the right side of the start line and going full speed. Being over the start line at the end of the 30 seconds puts you in last place. Be careful not to "jump the start."

Cutting inside a buoy AT ANY TIME will incur a 50 point penalty per buoy.

Points structure goes like this.

- 1st place (per heat) 400 pts
- 2nd place 300 pts
- 3rd place 225 pts
- 4th place 169 pts
- 5th place 125 pts
- 6th place 96 pts

In five rounds you have the potential to acquire up to 2,000 pts.

Good luck and good racing. Remember to place your racing pictures and videos on the AquaCraft Facebook page!

Ordering Replacement Parts

To order replacement parts for the AquaCraft GP-1 Ultra Mini Hydroplane, use the order numbers in the replacement parts list. Replacement parts can be purchased from your local hobby shop or by mail order. If you need assistance locating a dealer to purchase parts, visit www.hobbico.com and click on "Where to buy". If you are missing parts, contact Hobbico Product Support at:

Phone: 217.398.8970

Fax: 217.398.7721

E-mail: productsupport@hobbico.com

Parts List

AQUB6240	Cowl
AQUB6268	Wire Drive with Prop Shaft
AQUB8763	Rudder linkage w/Control Arm
AQUB7913	Motor Coupler
AQUB9282	Turn Fin
AQUB7914	Motor Mount
AQUG7005	28-35-2200kV Inrunner Brushless Marine Motor
AQUB9548	28mm CNC Water Jacket
AQUM7003	30-Amp Water Cooled Motor Controller
AQUB8742	Rudder Support Brackets
AQUB8735	Rudder Assembly Complete
AQUB8736	Rudder
AQUB8737	Rudder O-Ring
AQUB8738	Rudder Control Arm
AQUB9277	Transom Drain Plug
AQUB7757	30mm FRP Prop
AQUB9045	Water Pickup
AQUM7050	Steering Servo
AQUB7852	Drive Dog with Prop Nut
TACJ0245	Tactic TTX240 2-Channel SLT 2.4GHz Radio System
TACL0324	Tactic TR324 3-Channel SLT 2.4GHz Receiver

AQUACRAFT®

Models