

REEFRACER™



AQUACRAFT™
Models by **HOBBICO®**

Warranty

- AquaCraft™ will warrant this kit for 90 days after the purchase from defects in materials or workmanship. AquaCraft will either repair or replace, at no charge, the incorrectly made part.
- Make sure you save the receipt or invoice you were given when you bought your model! It is your proof of purchase and we must see it before we can honor the warranty.
- To return your Reef Racer™ for repairs covered under warranty, you should send your boat to:

Hobby Services
3002 N. Apollo Drive, Suite 1
Champaign, Illinois 61822
Attn: Service Department
Phone: (217) 398-0007 9:00 am - 5:00 pm Central Time M-F
E-mail: hobbyservices@hobbico.com

Before Building:

Thank you for purchasing the Reef Racer! This manual contains the instructions you need to safely operate and maintain your boat. We want the operation of this boat to be a success so **BEFORE** preparing the Reef Racer for action please read this manual thoroughly. If for any reason you think that this model is not for you, return it to your local dealer immediately. **PLEASE NOTE: Your hobby dealer cannot accept a return on any model after the final assembly sequence has begun.**

TABLE OF CONTENTS

INTRODUCTION	2
SAFETY PRECAUTIONS.....	2
REPAIR SERVICE	2
SPECIFICATION & DESCRIPTION CHANGES	2
USEFUL TOOLBOX ITEMS	2
FINAL ASSEMBLY	3
Transmitter Assembly	3
Battery Pack Charging.....	3
Install the Battery	4
Check the Radio System	4
RUNNING THE REEF RACER	5
MAINTENANCE	5
ORDERING REPLACEMENT PARTS.....	6
BOAT TERMINOLOGY	6
RACING	6

INTRODUCTION

Thank you for purchasing the AquaCraft Reef Racer! This manual contains the instructions you need to safely build, operate and maintain your R/C boat. Read over this manual thoroughly before operating the Reef Racer.

SAFETY PRECAUTIONS

- Do not attempt to charge battery packs in the immediate vicinity of swimming pools, lakes, rivers, oceans, inland seas, etc. Above all, **NEVER ATTEMPT TO PLUG IN THE WALL CHARGER IF YOU, THE CHARGER, OR THE BATTERY PACK ARE WET.**
- This boat is controlled by radio signals, which are susceptible to possible interference from other R/C transmitters, paging systems, or other electrical noise. **Before turning your radio on**, make sure no one else in the area is operating a radio on the same frequency (channel).
- Do not touch the propeller anytime the electronics are turned "ON". **Pay close attention** to items such as loose clothing, shirtsleeves, ties, scarves, long hair or any loose objects that may come in contact with the spinning propeller. If your fingers, hands, etc. come in contact with the spinning propeller, you may be severely injured.
- The speed and mass of this boat can inflict property damage and severe personal injury if a collision occurs. **Never run this boat in the presence of swimmers** or where the possibility of collision with people or property exists.
- Electric motors can generate considerable heat. **Do not touch any part of your motor until it has cooled.**

If the buyer is not prepared to accept the liability associated with the use of this product, the buyer is advised to return this kit immediately in new and unused condition to the place of purchase.

REPAIR SERVICE

Repair service is available anytime.

After the 90-day warranty, you can still have your Reef Racer repaired for a small charge by the experts at AquaCraft's authorized repair facility, **Hobby Services**, at the address listed on the front page of this manual.

To speed up the repair process,
please follow the instructions below.

1. Under all circumstances return the **ENTIRE** system: battery pack, charger, boat and radio.
2. Make sure the electronics are turned off and all batteries are removed.
3. Send written instructions which include a list of all items returned, a **THOROUGH** explanation of the problem, the service needed and your phone number during the day. If you expect the repair to be covered under warranty, be sure to include a proof-of-purchase date (your store receipt or purchase invoice).
4. Also be sure to send your full return address.

SPECIFICATION & DESCRIPTION CHANGES

All pictures, descriptions, and specifications found in this instruction manual are subject to change without notice. AquaCraft maintains no responsibility for inadvertent errors in this manual.

USEFUL TOOLBOX ITEMS

As with any hobby, it is a good idea to assemble a useful collection of tools to bring along anytime you head out to the pond. Here are some items you may wish to keep handy.

- Phillips Screwdriver (HCAR1024)
- 1.5mm Hex Driver (HCAR1150)
- 5.5mm Socket or Wrench
- Thread Locking Compound (GPMR6060)
- Paper Towels

FINAL ASSEMBLY

Decals have been provided for your Reef Racer. Simply cut them out, peel, and stick! See the box for recommended decal placement.

TRANSMITTER ASSEMBLY

Important Note: The transmitter is not water resistant and should be kept dry at all times.

❑ 1. Remove the transmitter antenna from the parts bag and screw it into the top of the transmitter. To ensure that the antenna is attached, lightly pull on the base of the antenna. If it slides out, it is not installed properly.

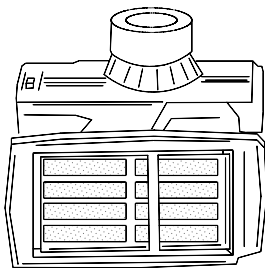
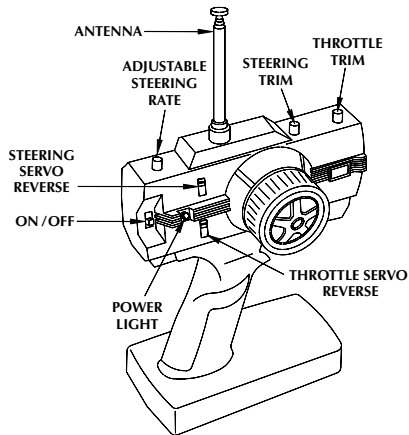

Install (8) new "AA" batteries

❑ 2. Slide off the battery door on the bottom of the transmitter. Install 8 fresh "AA" batteries into the bottom of the transmitter in the configuration molded into the battery holder. Re-install the battery door onto the bottom of the transmitter.

❑ 3. Turn the transmitter on using the switch on the front. The red LED light next to the on/off switch should light up. If the LED does not light up, turn the transmitter off and check to make sure that the batteries are installed properly. **If you see a flashing LED, the batteries are low and need to be replaced.**

BATTERY PACK CHARGING

- The wall charger included with the Reef Racer is a 2-hour quick charger. **Never leave the charger and battery plugged in overnight!**
- **Never** leave a charger and battery pack unattended while charging!
- After running the boat, **the battery will be hot.** Always allow the battery to cool completely before recharging.

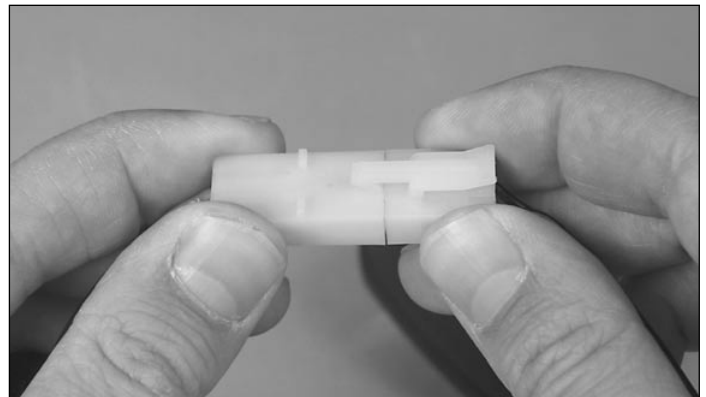
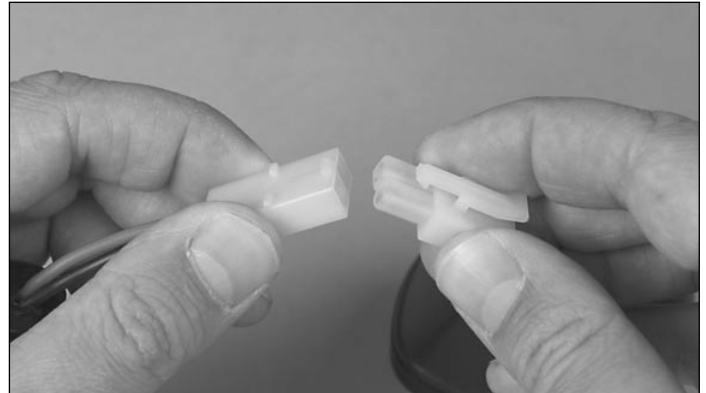

❑ 1. Join the charger and battery connectors as shown. **Do not force them together;** they are designed to fit together only one way.

❑ 2. Plug the charger into a 110V AC outlet. The battery indicator LED should be lit. If not, check your charger/battery connection. **Note: The only function of the LED is to let you know that the battery is connected; it will not tell you when charging is completed.**

❑ 3. Check the battery pack every 15 minutes, when the battery pack begins to warm up noticeably, charging is complete. Typically, it will only take 2 hours to charge a dead battery. **Note: If the battery is not completely dead when you start charging, it will warm up faster.**

Important! Never allow the battery pack to get hot while charging! This indicates that the pack is overcharged and will decrease its useful life.

4. Disconnect the battery pack by pushing the small tab while gently pulling the connectors apart. Unplug the charger unit from the wall.

INSTALL THE BATTERY

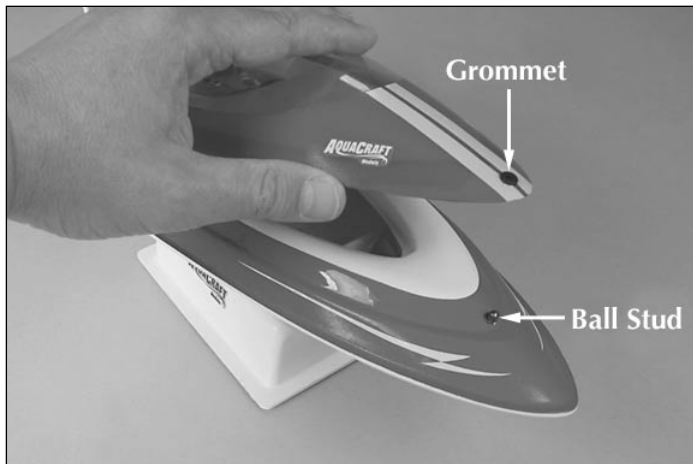

❑1. The hatch of the Reef Runner is secured by the rubber grommet and ball stud assembly located at the front of the boat. Open the hatch of the Reef Racer by gently lifting as shown.

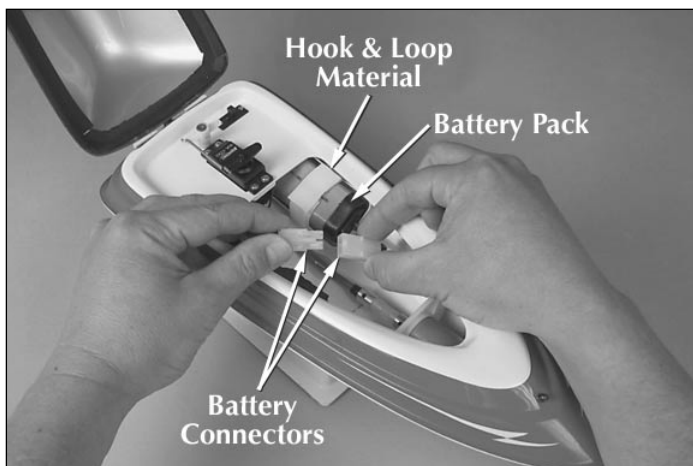

❑2. Secure the battery pack to the battery tray with the provided hook & loop material as shown and plug the battery pack into the boat's battery connector. Do not force them together; they are designed to fit together only one way.

CHECK THE RADIO SYSTEM

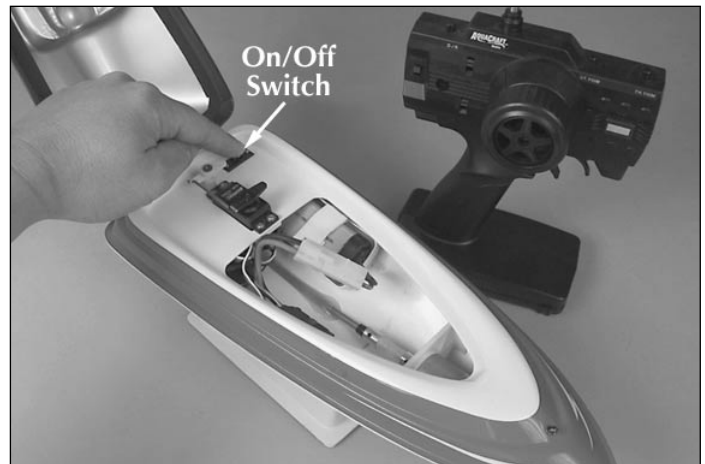

❑1. Turn the power "ON" to the transmitter and the boat (**in that order**). Close the hatch by pushing the deck and hull halves together and making sure that the grommet fits over the ball stud securely.

❑2. Standing behind the Reef Racer, rotate the wheel to the left. The back of the rudder should move towards the left. Move the wheel to the right. The back of the rudder should move towards the right. If this is not the case, simply move the steering servo reverse switch to the other position.

❑8. **Using care to avoid the propeller**, slowly squeeze the throttle trigger of the transmitter. This will start the propeller moving in a counter-clockwise direction. If this is not the case, try moving the throttle servo reversing switch to the other position.

❑9. The D/R knob located on top of the transmitter is the steering rate adjustment. Turning the knob to the right increases the movement of the rudder while turning it to the left decreases the rudder movement.

❑10. Turn the power "OFF" to your boat and then your transmitter, **in that order**.

RUNNING THE REEF RACER

- Before running your Reef Racer, it is a good idea to check over all screws to make sure they are securely fastened.
- Place the boat in water that is at least 8" deep and free of obstacles (weeds, rocks, sticks, ducks, muskrats, etc.).
- Slowly advance the throttle to full speed and note if the boat has a tendency to turn right or left. Adjust the steering trim knob on your transmitter until the boat runs in a straight line when the steering wheel is at neutral.
- **CAUTION:** Running in windy conditions will increase the chances of water entering the vessel.
- Total run time of the Reef Racer is approximately 10 minutes (assuming you begin with a fully charged battery pack). When you notice a decrease in power, it means the battery pack is nearly drained and it's time to head for shore. As soon as the boat reaches shore, turn off the power to the boat and transmitter (**in that order**).
- **CAUTION:** The motor and battery may be hot! Allow it to cool for a few minutes before attempting to remove the battery pack.
- Your Reef Racer may take on small amounts of water when running in rough water. Keep a roll of paper towels handy and dry out the hull interior after every run.
- Always store your Reef Racer with the canopy/hatch cover opened to allow the interior to dry out completely. If you neglect to do this, it may result in corrosion of the electronic components.
- **IMPORTANT:** If, for whatever reason, your boat takes on a large amount of water, swamps or sinks, causing the radio equipment to get wet, you must do the following immediately: Remove the battery pack and radio equipment from the boat. Allow the components to air dry completely before reassembling. Reinstall the components and check for proper operation before running the boat in water.

The Waiting Game

If your Reef Racer boat should happen to stall, water currents will *slowly* carry it to shore. The bad news is that the boat could be carried to the opposite shore. When surveying areas to run your Reef Racer, keep variables in mind such as wind direction, size of the lake, strength of river currents, etc.

HELPFUL TIP:

Use a fishing rod with at least 12lb. line and a tennis ball tied to the end to retrieve a stalled boat.

GOOD LUCK AND GREAT BOATING!

MAINTENANCE

It is important to periodically (every 10-15 battery packs) remove the drive shaft and re-lube with a thin coat of petroleum jelly or light grease. This procedure will require a 1.5mm hex driver. **Make sure that power to the boat is "OFF" during this procedure.**

1. Open the battery compartment and locate the rudder arm.

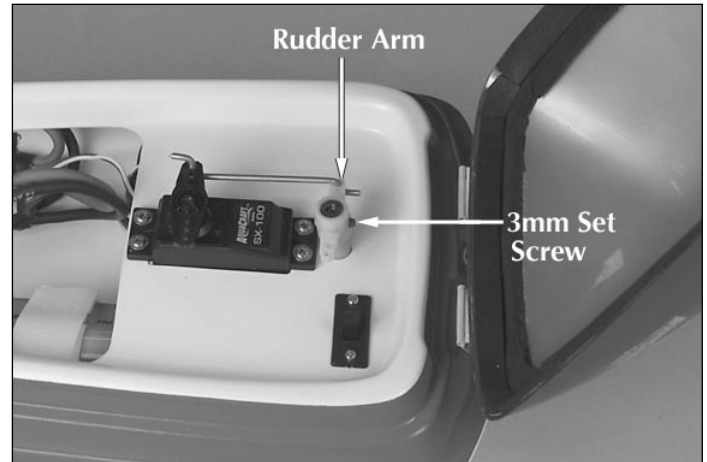

2. Loosen the 3mm rudder arm set screw using a 1.5mm hex driver and pull the rudder away from the hull.

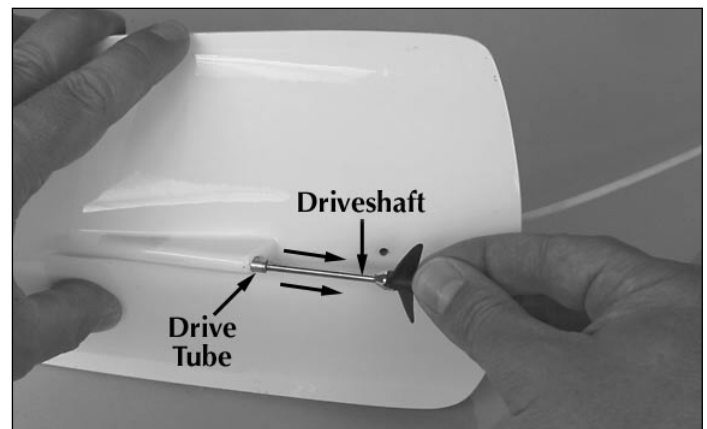
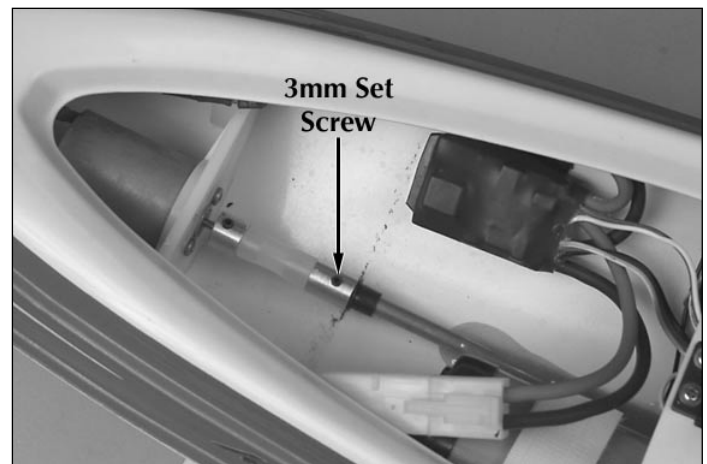

3. Loosen the 1.5mm set screw located on the drive coupler assembly, and pull the shaft out as shown.

❑ 4. After applying lubricant to the shaft, re-insert the shaft into the drive tube and rotate it while slowly pushing it back into place.

❑ 5. Re-tighten the 1.5mm set screw on the coupler assembly, making sure that the set screw rests on the flat spot of the drive shaft. Use thread lock compound on the set screw.

❑ 6. Re-insert the rudder and put the rudder arm back in place. Re-tighten the 1.5mm rudder arm set screw.

BOAT TERMINOLOGY

- **BOW:** The front of the boat
- **STERN:** The back of the boat
- **PORT:** This is the left side of the boat when aboard and facing the front (bow).
- **STARBOARD:** This is the right side of the boat when aboard and facing the front (bow).
- **HULL:** The body of the boat.
- **DECK:** The top of the boat.

RACING

Although it is very enjoyable to go out and run the Reef Racer by yourself, we think the real fun and excitement is experienced when you get involved in *RACING!*

Racing does not have to be an organized and sanctioned competition to be fun. In fact, small informal races can be very exciting without the stress that comes with formal events.

Here are some suggestions for setting up a simple racecourse for boats:

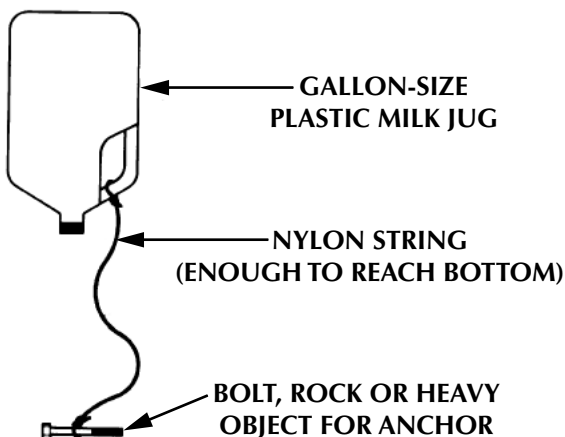

- Make 2 to 4 simple and inexpensive "marker buoys" with empty milk jugs, string and heavy objects for anchors, similar to the above sketch.

SAMPLE "DRAG RACING" COURSE

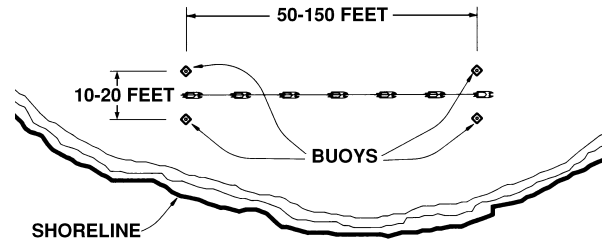

- For "drag racing" place the buoys similar to the above sketch.

SAMPLE "OVAL" RACE COURSE

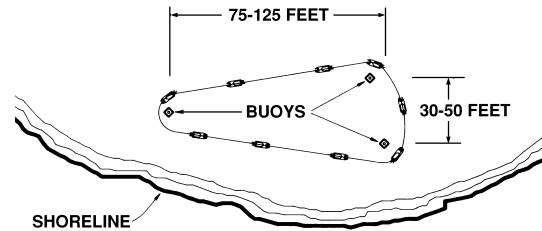

- For "oval racing" place the buoys similar to the above sketch. **NOTE:** The above patterns are not based on any sort of official standards; therefore, you may set up racecourses any way you desire, using your imagination to make the races more interesting. Usually the smaller courses will provide more action and excitement.

The length of the races can be determined by a set number of **laps** around the buoys (for example, the first boat to complete 5 laps is the winner); or by **time** (for example, whoever is leading at the end of two minutes is the winner).

ORDERING REPLACEMENT PARTS

To order replacement parts for the AquaCraft Reef Racer, use the order numbers in the **Replacement Parts List** that follows. Replacement parts are available only as listed and can be purchased from hobby shops or mail order/ Internet order firms. Hardware items (screws, nuts, bolts) are also available from these outlets. If you need assistance locating a dealer to purchase parts, visit www.hobbico.com and click on "Where to Buy". If this kit is missing parts, contact **Hobbico Product Support**.

REPLACEMENT PARTS LIST

Order #	Item
HCAB6307	DECAL SET
HCAB7001	GROMMET/BALL STUD (6)
HCAB7755	PROP SET (2)
HCAB7855	SHAFT SET
HCAB8702	RUDDER SET
HCAB9020	SPEED CONTROL
HCAG3477	MOTOR WITH WIRES
HCAM7033	NIMH BATTERY 7.2V
HCAP0127	BATTERY CHARGER

CHECK OUT THESE OTHER SENSATIONAL AQUACRAFT PRODUCTS!

AquaCraft™ by Hobbico® Air Force™ Air Boats

- *The new "force" in R/C boating!*
- *Features a FIBERGLASS hull and deck!*

Air Force Ready-to-Run: HCAB27**

RTR Version Includes: AquaCraft Pro 46 engine, AquaCraft 2-channel radio w/2 standard servos, propeller, engine video

Air Force Almost Ready-to-Run: HCAB5027

ARR Version Requires: .40- to .46-size engine, 2-channel radio, propeller



Overall Length: 36 in
Hull Length: 30.5 in
Beam: 13.5 in

It's powered by air...and fueled by fun! The AquaCraft Air Force gets high marks for quality, convenience and performance, and it's ready for action in just minutes. Its construction advantage? A *fiberglass* hull that's durable, lightweight – and resistant to the effects of fuel residue that can ruin ABS and plastic hulls. The pre-joined deck and hull reduce final assembly, and stainless steel hardware is also supplied. There's even a display stand that doubles as a handy carrying tote. The **RTR** comes in one of six brilliant, gel-coated colors, along with an AquaCraft Pro 46 engine, 2-channel AquaCraft radio made by Futaba®, and prop. The white gel-coated **ARR** version requires engine, radio and prop. Both require glow starter, engine starter, fuel, 12 "AA" batteries.

AquaCraft™ by Hobbico® Nitro Hammer™ GP RTR (HCAB26)**

- *Fully assembled - with fiberglass deck and hull!*
- *FREE engine video with tips for tuning and maintenance!*

Includes: recoil-started AquaCraft .15 Marine w/tuned pipe, AquaCraft 2-channel Pistol Radio System, engine break-in video and stand. Requires: 20% glow fuel, glow starter & 12 "AA" batteries

Strike fast, with the Nitro Hammer's ready-to-run ease and nitro power! Factory-built, it features first-class materials throughout - from the durable fiberglass hull (available factory-finished in six custom colors) to the stainless steel hardware that resists rust and corrosion. The long rudder cuts deep for razor-sharp turns. Trim tab/turn fins on either side adjust to ensure smooth, straight running. The AquaCraft 2-channel pistol radio's steering dual rates and fine steering/throttle trims add more precision to your control. In addition to fast, easy recoil starting, the .15 Marine ABC engine includes a water-cooled head, rotary carburetor with adjustable high and low needles, dual ball bearings and glow plug. You'll waste no time (or fuel!) during fill-ups, thanks to the tank's flip-top cap and efficient primer button. And like the engine and fuel tank, the Nitro Hammer's radio gear and electronics arrive already installed, in a protective hatch you can quickly access just by removing one pin. Simplicity, speed, style...the Nitro Hammer wins every way!



Length: 24 in
Beam: 8.75 in

